

General Description

Series F flow control valves provide precise control of flow and shut-off in one direction, and automatically permit full flow in the opposite direction.

Operation

A two-step needle allows fine adjustment at low flow by using the first three turns of the adjusting knob. The next three turns open the valve to full flow, and also provide standard throttling adjustments.

Features

- The exclusive “Colorflow” color-band reference scale on the valve stem is a great convenience and time-saver in setting the valve originally and in returning it to any previous setting.
- A simple set screw locks the valve on any desired setting.
- A tamperproof option (T) feature is also available to prevent accidental or intentional adjustment of flow setting.

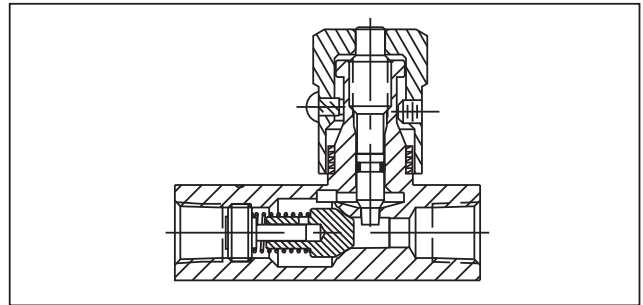
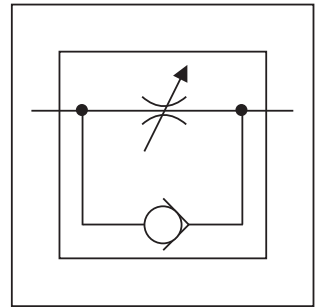

Specifications

Maximum Operating Pressure	Brass:	140 Bar (2000 PSI); except for F1600 brass which is 35 Bar (500 PSI)	Poppets	Soft seal poppet in brass 200 - 820 sizes
	Steel & Stainless Steel:	345 Bar (5000 PSI) for 200 thru 1220; 207 Bar (3000 PSI) for all other sizes		Solid metal 416 stainless steel poppet on all other sizes and styles
Material	Body	See ordering code	Nominal Cracking Pressure	0.4 Bar (5 PSI) standard
	Knob	Steel - Zinc plated		Temperature Range of Seal Compound
Spring	316 Stainless Steel		-26°C to +205°C (-15°F to +400°F) Fluorocarbon	
Needle	416 Stainless Steel			
Poppet	416 Stainless Steel			
Retainer	416 Stainless Steel			
Stainless Steel Bodies	303 Stainless Steel			

Ordering Information

Flow Control Valves Series F

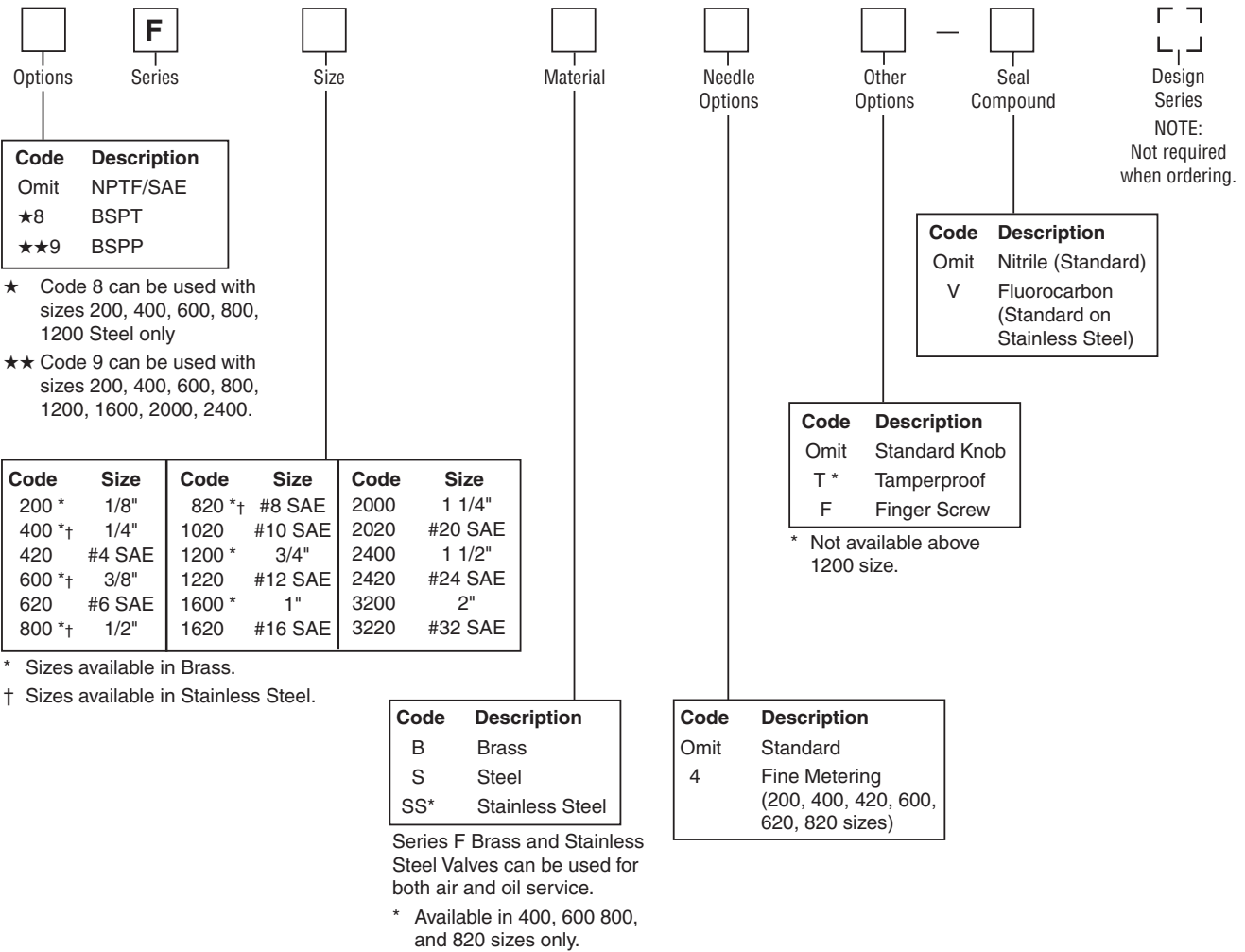

Model Number	Free Flow Rate, Max. LPM (GPM)	Free Flow Orifice Area in. ²	Free Flow C _v	Effective Orifice Area, Control Flow in. ²	Effective Control Flow C _v
F200	11 (3)	0.023	0.53	0.0102	0.230
F420	11 (3)	0.023	0.53	0.0102	0.230
F400	19 (5)	0.068	1.56	0.0194	0.433
F620	19 (5)	0.068	1.56	0.0194	0.433
F600	30 (8)	0.099	2.27	0.0344	0.787
F820	30 (8)	0.099	2.27	0.0344	0.787
F800	57 (15)	0.224	5.11	0.0427	0.976
F1020	57 (15)	0.224	5.11	0.0427	0.976
F1200	95 (25)	0.348	7.95	0.1080	2.470
F1220	95 (25)	0.348	7.95	0.1080	2.470
F1600	151 (40)	0.453	10.35	0.2300	5.250
F1620	151 (40)	0.453	10.35	0.3070	7.000
F2000	265 (70)	0.855	19.52	0.2300	5.250
F2020	265 (70)	0.855	19.52	0.3710	8.470
F2400	379 (100)	0.955	21.82	0.2300	5.250
F2420	379 (100)	0.955	21.82	0.3710	8.470
F3200	568 (150)	1.046	23.90	0.2300	5.250
F3220	568 (150)	1.046	23.90	0.6010	13.410

Model Number	Effective Orifice Area Control Flow in. ²	Effective Control Flow C _v
F400-4	0.0044	0.0758
F600-4	0.0097	0.153
F620-4	0.0044	0.0758
F820-4	0.0097	0.153

