

# C Series Check Valves

## Introduction

Parker C Series Check Valves are designed for uni-directional flow control of fluids and gases in industries such as chemical processing, oil and gas production and transmission, pharmaceutical, pulp and paper, power and utilities.

## Features

- ▶ Resilient, custom molded, blow-out resistant seat design
- ▶ Back stopped poppet minimizes spring stress
- ▶ 100% factory tested for both crack and reseal
- ▶ Cracking pressures include: 1/3, 1, 5, 10, 25, 50, 75, and 100 psi.
- ▶ Port connections include male and female NPT, CPI™, A-LOK®, UltraSeal, VacuSeal, BSP, SAE and Seal-Lok®
- ▶ Heat code traceability

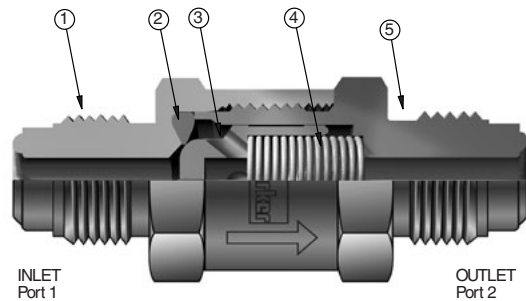

Model Shown: 4V-C4L-5-SS

## Specifications

### Pressure Rating:\*\*

316 SS – 1/8" to 3/4": .....6000 psig (414 bar) CWP  
 1": .....5000 psig (345 bar) CWP  
 PTFE Seats, all sizes: .....4000 psig (276 bar) CWP  
 Brass – 1/8" to 1": .....3000 psig (207 bar) CWP

### Temperature Rating:

Fluorocarbon Rubber..... -15°F to +400°F (-26°C to +204°C)  
 Nitrile ..... -30°F to +275°F (-34°C to +135°C)  
 Ethylene Propylene Rubber.. -70°F to +275°F (-57°C to +135°C)  
 Neoprene Rubber ..... -45°F to +250°F (-43°C to +121°C)  
 PTFE ..... -65°F to +400°F (-54°C to +204°C)  
 Highly Fluorinated Fluorocarbon Rubber  
 ..... -15°F to +200°F (-26°C to +93°C)

Orifice: .....078" to .656" (2.0 mm to 16.7 mm)

C<sub>v</sub>: ..... .18 to 6.56

## Materials of Construction

Item #	Part Description	Stainless Steel	Brass
1	Cap	ASTM A 276, Type 316	ASTM B 16, Alloy C36000
2	Seat*	Fluorocarbon Rubber*	
3	Poppet	ASTM A 479, Type 316	ASTM B 16, Alloy C36000
4	Spring	316 Stainless Steel	
5	Body	ASTM A 276, Type 316	ASTM B 16, Alloy C36000

\* Optional seat materials are available. See How to Order section.  
 Lubrication: Perfluorinated Polyether.

**Note:** PTFE seated valves employ an additional PTFE coated 316 SS gasket between the seat and the body and are distinguishable from elastomeric seated valves by the gap designed between the body and cap.

\*\*See Pressure Rating note on page 4.

## Flow Calculations with 1000 psig (69 bar) Inlet Pressure

Valve Series	Maximum C <sub>v</sub>	Pressure Drop ΔP		Water @ 60°F (16°C)		Air @ 60°F (16°C)	
		psig	bar	gpm	m <sup>3</sup> /hr	SCFM	m <sup>3</sup> /hr
C2	0.31	10	0.7	1.0	0.2	30.8	52.1
		50	3.4	2.2	0.5	67.2	112.8
		100	6.9	3.1	0.7	92.0	155.3
C4	0.75	10	0.7	2.4	0.5	74.6	126.1
		50	3.4	5.3	1.2	162.7	273.0
		100	6.9	7.5	1.7	222.8	376.2
C6	2.26	10	0.7	7.1	1.6	225.3	380.9
		50	3.4	16.0	3.6	495.2	831.0
		100	6.9	22.6	5.1	685.1	1157.2
C8	3.53	10	0.7	11.2	2.5	352.0	595.0
		50	3.4	25.0	5.6	774.3	1299.4
		100	6.9	35.3	8.0	1072.4	1811.6
C12	6.01	10	0.7	19.0	4.3	596.6	1008.3
		50	3.4	42.5	9.6	1287.5	2160.4
		100	6.9	60.1	13.7	1738.5	2934.5
C16	6.56	10	0.7	20.7	4.7	648.9	1096.6
		50	3.4	46.4	10.5	1379.4	2314.7
		100	6.9	65.6	14.9	1824.4	3077.6

## Crack and Re-Seal Performance

Check Valve Rated Crack Pressure		Minimum Acceptable Crack Pressure		Maximum Acceptable Crack Pressure		Maximum Re-seal Back Pressure	
psig	bar	psig	bar	psig	bar	psig	bar
1/3	0.02	0	0.00	1	0.07	4	0.28
1	0.07	0	0.00	3	0.21	4	0.28
5	0.34	3	0.21	8	0.55	3 BCP	0.21 BCP
10	0.69	7	0.48	13	0.90	3 BCP	0.21 BCP
25	1.72	20	1.38	30	2.07	4 BCP	0.28 BCP
50	3.45	40	2.76	60	4.14	5 BCP	0.34 BCP
75	5.17	60	4.14	90	6.21	7 BCP	0.48 BCP
100	6.89	80	5.52	120	8.27	10 BCP	0.69 BCP

BCP means "Below Cracking Pressure."

Cracking pressure is defined as the upstream pressure at which a detectable flow is measured.

Re-seal pressure is defined as the downstream pressure at which the check valve closes bubble-tight.

**Example:** For a valve with a spring having a rated cracking pressure of 25 psig (1.72 bar), the actual cracking pressure ranges between 20 and 30 psig (1.38 and 2.07 bar). The re-seal pressure range would be 16 to 20 psig (1.10 to 1.38 bar). Check valves having springs with rated crack pressures of 3 psig (0.21 bar) or less may require up to 4 psig (0.28 bar) back pressure to re-seal bubble-tight.

**Note:** Check valves which are not actuated for a period of time may initially crack at higher than the above crack pressure ranges.

PTFE seated valves require a minimum back pressure of 100 psig (6.9 bar) to insure a leak-tight re-seal.

## Pressure vs. Temperature

**Note:** To determine MPa, multiply bar by 0.1

### Nitrile Seat

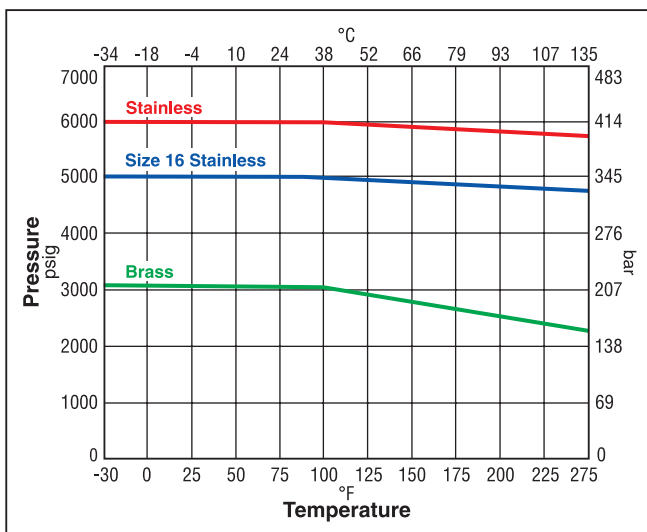

### Neoprene Seat

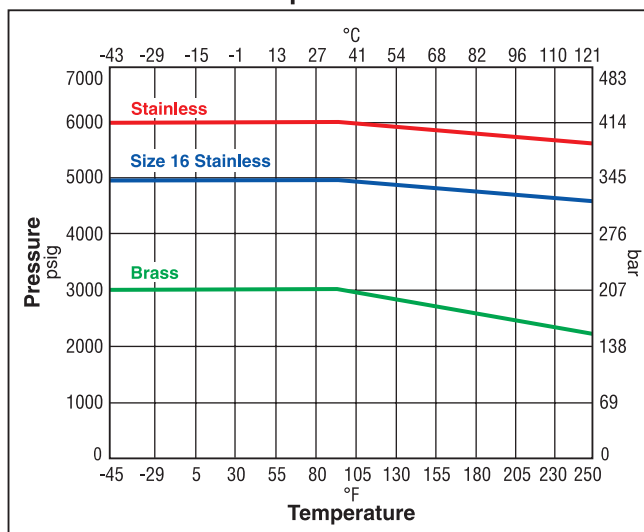

### Fluorocarbon Seat

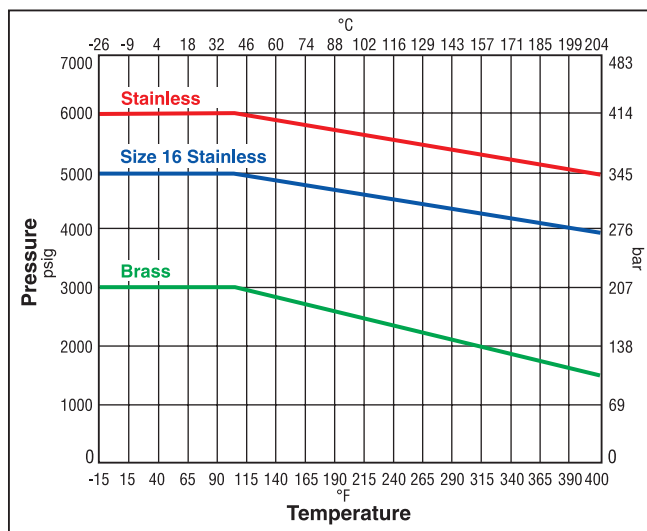

### Ethylene Propylene Seat

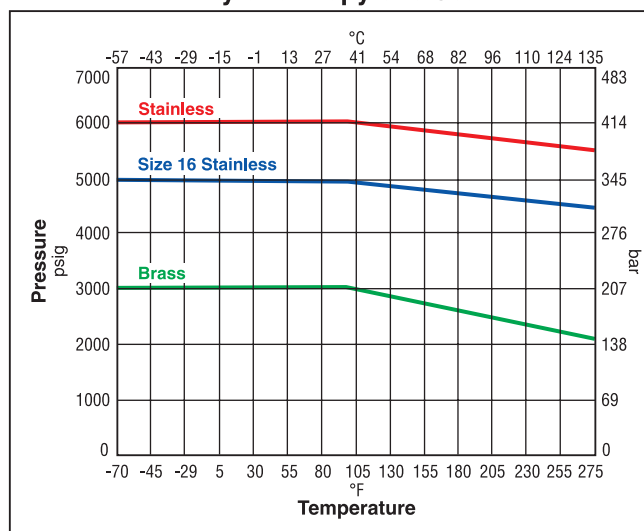

# C Series Check Valves

## Flow Data/Dimensions

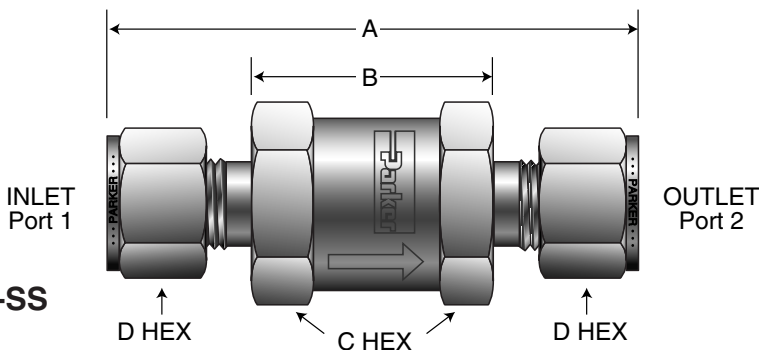

Model Shown: 4Z-C4L-1-SS

Dimensions in inches (millimeters) are for reference only, subject to change.

Basic Part Number	End Connections		Flow Data				Dimensions							
	Inlet Port 1	Outlet Port 2	Orifice		$C_V$	$X_T^*$	A†		B		C		D	
			Inch	mm			Inch	mm	Inch	mm	Inch	mm		
2A-C2L	1/8" A-LOK® Compression	1/8" A-LOK® Compression	.093	2.4	.22	0.46	2.29	58.2	1.09	27.7	.625	15.9	.438	11.1
2F-C2L	1/8" Female NPT	1/8" Female NPT	.125	3.2	.31	0.52	1.86	47.2	-	-	.625	15.9	-	-
2F5-C2L	1/8" Male SAE	1/8" Male SAE	.063	1.6	.16	0.42	1.83	46.5	1.08	27.4	.625	15.9	-	-
2G5-C2L	1/8" Female SAE	1/8" Female SAE	.063	1.6	.16	0.42	1.86	47.2	-	-	.625	15.9	-	-
2KF-C2L	1/8" Female BSP/ISO Tapered	1/8" Female BSP/ISO Tapered	.125	3.2	.31	0.52	1.86	47.2	-	-	.625	15.9	-	-
2KM-C2L	1/8" Male BSP/ISO Tapered	1/8" Male BSP/ISO Tapered	.125	3.2	.31	0.52	1.77	45.0	1.00	25.4	.625	15.9	-	-
2M-C2L	1/8" Male NPT	1/8" Male NPT	.125	3.2	.31	0.52	1.77	45.0	1.01	25.7	.625	15.9	-	-
2TA-C2L	1/8" Tube Adapter	1/8" Tube Adapter	.078	2.0	.18	0.43	2.07	52.6	.88	22.4	.625	15.9	-	-
2Z-C2L	1/8" CPI™ Compression	1/8" CPI™ Compression	.093	2.4	.22	0.46	2.29	58.2	1.09	27.7	.625	15.9	.438	11.1
M3A-C2L	3mm A-LOK® Compression	3mm A-LOK® Compression	.086	2.2	.20	0.45	2.30	58.4	1.05	26.7	.625	15.9	.472	12.0
M3Z-C2L	3mm CPI™ Compression	3mm CPI™ Compression	.086	2.2	.20	0.45	2.30	58.4	1.05	26.7	.625	15.9	.472	12.0
2M2A-C2L	1/8" Male NPT	1/8" A-LOK® Compression	.093	2.4	.22	0.46	2.03	51.6	1.05	26.7	.625	15.9	.438	11.1
2M2F-C2L	1/8" Male NPT	1/8" Female NPT	.125	3.2	.31	0.52	1.81	46.0	1.43	36.3	.625	15.9	-	-
2M2Z-C2L	1/8" Male NPT	1/8" CPI™ Compression	.093	2.4	.22	0.46	2.03	51.6	1.05	26.7	.625	15.9	.438	11.1
2F-C4L	1/8" Female NPT	1/8" Female NPT	.187	4.7	.75	0.53	2.01	51.1	-	-	.750	19.1	-	-
2M-C4L	1/8" Male NPT	1/8" Male NPT	.187	4.7	.75	0.53	1.82	46.2	1.06	26.9	.750	19.1	-	-
4A-C4L	1/4" A-LOK® Compression	1/4" A-LOK® Compression	.187	4.7	.75	0.53	2.42	61.5	1.03	26.2	.750	19.1	.563	14.3
4F-C4L	1/4" Female NPT	1/4" Female NPT	.187	4.7	.75	0.53	2.40	61.0	-	-	.750	19.1	-	-
4F5-C4L	1/4" Male SAE	1/4" Male SAE	.172	4.4	.66	0.52	2.02	51.3	1.15	29.2	.750	19.1	-	-
4G5-C4L	1/4" Female SAE	1/4" Female SAE	.172	4.4	.66	0.52	2.20	55.9	-	-	.750	19.1	-	-
4KF-C4L	1/4" Female BSP/ISO Tapered	1/4" Female BSP/ISO Tapered	.187	4.7	.75	0.53	2.40	61.0	-	-	.750	19.1	-	-
4KM-C4L	1/4" Male BSP/ISO Tapered	1/4" Male BSP/ISO Tapered	.281	4.7	.75	0.53	2.18	55.4	1.06	26.9	.750	19.1	-	-
4L-C4L	1/4" Seal-Lok®	1/4" Seal-Lok®	.172	4.4	.66	0.52	1.82	46.2	1.03	26.2	.750	19.1	-	-
4M-C4L	1/4" Male NPT	1/4" Male NPT	.187	4.7	.75	0.53	2.18	55.4	1.04	26.4	.750	19.1	-	-
4Q-C4L	1/4" UltraSeal	1/4" UltraSeal	.180	4.6	.72	0.53	1.97	50.0	1.04	26.4	.750	19.1	-	-
4V-C4L	1/4" VacuSeal	1/4" VacuSeal	.187	4.7	.75	0.53	2.22	56.4	.98	24.9	.750	19.1	-	-
4TA-C4L	1/4" Tube Adapter	1/4" Tube Adapter	.156	4.0	.58	0.52	2.35	59.7	1.07	27.2	.750	19.1	-	-
4Z-C4L	1/4" CPI™ Compression	1/4" CPI™ Compression	.187	4.7	.75	0.53	2.42	61.5	1.03	26.2	.750	19.1	.563	14.3
6A-C4L	3/8" A-LOK® Compression	3/8" A-LOK® Compression	.187	4.7	.75	0.53	2.55	64.8	1.03	26.2	.750	19.1	.688	17.5
6Z-C4L	3/8" CPI™ Compression	3/8" CPI™ Compression	.187	4.7	.75	0.53	2.55	64.8	1.03	26.2	.750	19.1	.688	17.5
M6A-C4L	6mm A-LOK® Compression	6mm A-LOK® Compression	.187	4.7	.75	0.53	2.43	61.7	1.03	26.2	.750	19.1	.551	14.0
M6Z-C4L	6mm CPI™ Compression	6mm CPI™ Compression	.187	4.7	.75	0.53	2.43	61.7	1.03	26.2	.750	19.1	.551	14.0
4M4A-C4L	1/4" Male NPT	1/4" A-LOK® Compression	.187	4.7	.75	0.53	2.29	58.2	1.02	25.9	.750	19.1	.563	14.3
4M4F-C4L	1/4" Male NPT	1/4" Female NPT	.187	4.7	.75	0.53	2.29	58.2	1.72	43.7	.750	19.1	-	-
4M4Z-C4L	1/4" Male NPT	1/4" CPI™ Compression	.187	4.7	.75	0.53	2.29	58.2	1.02	25.9	.750	19.1	.563	14.3
4M6A-C4L	1/4" Male NPT	3/8" A-LOK® Compression	.187	4.7	.75	0.53	2.35	59.7	1.02	25.9	.750	19.1	.688	17.5
4M6Z-C4L	1/4" Male NPT	3/8" CPI™ Compression	.187	4.7	.75	0.53	2.35	59.7	1.02	25.9	.750	19.1	.688	17.5
6A-C6L	3/8" A-LOK® Compression	3/8" A-LOK® Compression	.281	7.1	2.09	0.74	3.27	83.1	1.75	44.5	1.000	25.4	.688	17.5
6F-C6L	3/8" Female NPT	3/8" Female NPT	.359	9.1	2.26	0.77	3.03	77.0	-	-	1.000	25.4	-	-
6F5-C6L	3/8" Male SAE	3/8" Male SAE	.264	6.7	2.05	0.74	2.71	68.8	1.76	44.7	1.000	25.4	-	-
6G5-C6L	3/8" Female SAE	3/8" Female SAE	.264	6.7	2.05	0.74	2.96	75.2	-	-	1.000	25.4	-	-
6KF-C6L	3/8" Female BSP/ISO Tapered	3/8" Female BSP/ISO Tapered	.359	9.1	2.26	0.77	3.03	77.0	-	-	1.000	25.4	-	-
6KM-C6L	3/8" Male BSP/ISO Tapered	3/8" Male BSP/ISO Tapered	.359	9.1	2.26	0.77	2.96	75.2	1.84	46.7	1.000	25.4	-	-
6L-C6L	3/8" Seal-Lok®	3/8" Seal-Lok®	.264	6.7	2.05	0.74	2.65	67.3	1.77	45.0	1.000	25.4	-	-
6M-C6L	3/8" Male NPT	3/8" Male NPT	.359	9.1	2.26	0.77	2.96	75.2	1.82	46.2	1.000	25.4	-	-
6Q-C6L	3/8" UltraSeal	3/8" UltraSeal	.250	6.4	2.02	0.73	2.75	69.9	1.80	45.7	1.000	25.4	-	-
6TA-C6L	3/8" Tube Adapter	3/8" Tube Adapter	.281	7.1	2.09	0.74	3.24	82.3	1.80	45.7	1.000	25.4	-	-
6Z-C6L	3/8" CPI™ Compression	3/8" CPI™ Compression	.281	7.1	2.09	0.74	3.27	83.1	1.75	44.5	1.000	25.4	.688	17.5

Pressure Rating and Tubing Selection: For working pressures of A-LOK® and CPI™ tube connections, please see the Instrument Tubing Selection Guide (Bulletin 4200-TS), found in the Technical Section of the Parker Instrumentation Process Control Binder, or the Parker Instrument Tube Fitting Installation Manual (Bulletin 4200-B4).

For working pressures of valves with external or internal pipe threads, please see Catalog 4260, Instrumentation Pipe Fittings.

\* Tested in accordance with ISA S75.02. Gas flow will be choked when  $P_1 - P_2 / P_1 = x_T$ .

† For CPI™ and A-LOK®, dimensions are measured with nuts in the finger tight position.

# C Series Check Valves

## Flow Data/Dimensions (Continued)

Dimensions in inches (millimeters) are for reference only, subject to change.

Basic Part Number	End Connections		Flow Data				Dimensions							
	Inlet Port 1	Outlet Port 2	Orifice		$C_V$	$X_T^*$	A†		B		C		D	
			Inch	mm			Inch	mm	Inch	mm	Inch	mm	Inch	mm
8A-C6L	1/2" A-LOK® Compression	1/2" A-LOK® Compression	.359	9.1	2.26	0.77	3.55	90.2	1.81	46.0	1.000	25.4	.875	22.2
8Z-C6L	1/2" CPI™ Compression	1/2" CPI™ Compression	.359	9.1	2.26	0.77	3.55	90.2	1.81	46.0	1.000	25.4	.875	22.2
M8A-C6L	8mm A-LOK® Compression	8mm A-LOK® Compression	.250	6.4	2.02	0.73	3.33	84.6	1.87	47.5	1.000	25.4	.630	16.0
M8Z-C6L	8mm CPI™ Compression	8mm CPI™ Compression	.250	6.4	2.02	0.73	3.33	84.6	1.87	47.5	1.000	25.4	.630	16.0
M10A-C6L	10mm A-LOK® Compression	10mm A-LOK® Compression	.312	7.9	2.16	0.75	3.35	85.1	1.81	46.0	1.000	25.4	.748	19.0
M10Z-C6L	10mm CPI™ Compression	10mm CPI™ Compression	.312	7.9	2.16	0.75	3.35	85.1	1.81	46.0	1.000	25.4	.748	19.0
6M6A-C6L	3/8" Male NPT	3/8" A-LOK® Compression	.281	7.1	2.09	0.74	3.09	78.5	1.76	44.7	1.000	25.4	.688	17.5
6M6F-C6L	3/8" Male NPT	3/8" Female NPT	.359	9.1	2.26	0.77	2.95	74.9	2.38	60.5	1.000	25.4	-	-
6M6Z-C6L	3/8" Male NPT	3/8" CPI™ Compression	.281	7.1	2.09	0.74	3.09	78.5	1.76	44.7	1.000	25.4	.688	17.5
6M8A-C6L	3/8" Male NPT	1/2" A-LOK® Compression	.359	9.1	2.26	0.77	3.26	82.8	1.82	46.2	1.000	25.4	.875	22.2
6M8Z-C6L	3/8" Male NPT	1/2" CPI™ Compression	.359	9.1	2.26	0.77	3.26	82.8	1.82	46.2	1.000	25.4	.875	22.2
8A-C8L	1/2" A-LOK® Compression	1/2" A-LOK® Compression	.423	10.7	3.30	0.77	4.08	103.6	2.34	59.4	1.250	31.8	.875	22.2
8F-C8L	1/2" Female NPT	1/2" Female NPT	.453	11.5	3.53	0.81	3.56	90.4	-	-	1.250	31.8	-	-
8F5-C8L	1/2" Male SAE	1/2" Male SAE	.378	9.6	2.96	0.71	3.45	87.6	2.34	59.4	1.250	31.8	-	-
8G5-C8L	1/2" Female SAE	1/2" Female SAE	.453	11.5	3.53	0.81	3.56	90.4	-	-	1.250	31.8	-	-
8KF-C8L	1/2" Female BSP/ISO Tapered	1/2" Female BSP/ISO Tapered	.453	11.5	3.53	0.81	3.56	90.4	-	-	1.250	31.8	-	-
8KM-C8L	1/2" Male BSP/ISO Tapered	1/2" Male BSP/ISO Tapered	.453	11.5	3.53	0.81	3.56	90.4	2.06	52.3	1.250	31.8	-	-
8L-C8L	1/2" Seal-Lok®	1/2" Seal-Lok®	.378	9.6	2.96	0.71	3.22	81.8	2.21	56.1	1.250	31.8	-	-
8M-C8L	1/2" Male NPT	1/2" Male NPT	.453	11.5	3.53	0.81	3.56	90.4	2.05	52.1	1.250	31.8	-	-
8Q-C8L	1/2" UltraSeal	1/2" UltraSeal	.375	9.5	2.93	0.71	3.28	83.3	2.33	59.2	1.250	31.8	-	-
8TA-C8L	1/2" Tube Adapter	1/2" Tube Adapter	.375	9.5	2.93	0.71	4.04	102.6	1.78	45.2	1.250	31.8	-	-
8V-C8L	1/2" VacuSeal	1/2" VacuSeal	.406	10.3	3.17	0.75	3.56	90.4	2.05	52.1	1.250	31.8	-	-
8Z-C8L	1/2" CPI™ Compression	1/2" CPI™ Compression	.423	10.7	3.30	0.77	4.08	103.6	2.34	59.4	1.250	31.8	.875	22.2
M12A-C8L	12mm A-LOK® Compression	12mm A-LOK® Compression	.375	9.5	2.93	0.71	4.06	103.1	2.34	59.4	1.250	31.8	.866	22.0
M12Z-C8L	12mm CPI™ Compression	12mm CPI™ Compression	.375	9.5	2.93	0.71	4.06	103.1	2.34	59.4	1.250	31.8	.866	22.0
8M8A-C8L	1/2" Male NPT	1/2" A-LOK® Compression	.423	10.7	3.30	0.77	3.82	97.0	2.19	55.6	1.250	31.8	.875	22.2
8M8F-C8L	1/2" Male NPT	1/2" Female NPT	.453	11.5	3.53	0.81	3.56	90.4	2.80	71.1	1.250	31.8	-	-
8M8Z-C8L	1/2" Male NPT	1/2" CPI™ Compression	.423	10.7	3.30	0.77	3.82	97.0	2.19	55.6	1.250	31.8	.875	22.2
12A-C12L	3/4" A-LOK® Compression	3/4" A-LOK® Compression	.594	15.1	6.01	0.38	4.34	110.2	2.60	66.0	1.375	34.9	1.125	28.6
12F-C12L	3/4" Female NPT	3/4" Female NPT	.594	15.1	6.01	0.38	4.09	103.9	-	-	1.375	34.9	-	-
12F5-C12L	3/4" Male SAE	3/4" Male SAE	.594	15.1	6.01	0.38	4.05	102.9	2.59	65.8	1.375	34.9	-	-
12G5-C12L	3/4" Female SAE	3/4" Female SAE	.594	15.1	6.01	0.38	4.09	103.9	-	-	1.375	34.9	-	-
12KF-C12L	3/4" Female BSP/ISO Tapered	3/4" Female BSP/ISO Tapered	.594	15.1	6.01	0.38	4.09	103.9	-	-	1.375	34.9	-	-
12KM-C12L	3/4" Male BSP/ISO Tapered	3/4" Male BSP/ISO Tapered	.594	15.1	6.01	0.38	4.09	103.9	2.59	65.8	1.375	34.9	-	-
12L-C12L	3/4" Seal-Lok®	3/4" Seal-Lok®	.594	15.1	6.01	0.38	3.78	96.0	2.44	62.0	1.375	34.9	-	-
12M-C12L	3/4" Male NPT	3/4" Male NPT	.594	15.1	6.01	0.38	4.09	103.9	2.58	65.5	1.375	34.9	-	-
12Q-C12L	3/4" UltraSeal	3/4" UltraSeal	.500	12.7	5.63	0.37	3.78	96.0	2.64	67.1	1.375	34.9	-	-
12TA-C12L	3/4" Tube Adapter	3/4" Tube Adapter	.594	15.1	6.01	0.38	4.24	107.7	2.18	55.4	1.375	34.9	-	-
12V-C12L	3/4" VacuSeal	3/4" VacuSeal	.594	15.1	6.01	0.38	4.64	117.9	2.64	67.1	1.375	34.9	-	-
12Z-C12L	3/4" CPI™ Compression	3/4" CPI™ Compression	.594	15.1	6.01	0.38	4.34	110.2	2.60	66.0	1.375	34.9	1.125	28.6
M20A-C12L	20mm A-LOK® Compression	20mm A-LOK® Compression	.594	15.1	6.01	0.38	4.32	109.7	2.56	65.0	1.375	34.9	1.260	32.0
M20Z-C12L	20mm CPI™ Compression	20mm CPI™ Compression	.594	15.1	6.01	0.38	4.32	109.7	2.56	65.0	1.375	34.9	1.260	32.0
M22A-C12L	22mm A-LOK® Compression	22mm A-LOK® Compression	.594	15.1	6.01	0.38	4.30	109.2	2.56	65.0	1.375	34.9	1.260	32.0
M22Z-C12L	22mm CPI™ Compression	22mm CPI™ Compression	.594	15.1	6.01	0.38	4.30	109.2	2.56	65.0	1.375	34.9	1.260	32.0
12M12A-C12L	3/4" Male NPT	3/4" A-LOK® Compression	.594	15.1	6.01	0.38	4.22	107.2	2.59	65.8	1.375	34.9	1.125	28.6
12M12F-C12L	3/4" Male NPT	3/4" Female NPT	.594	15.1	6.01	0.38	4.09	103.9	3.34	84.8	1.375	34.9	-	-
12M12Z-C12L	3/4" Male NPT	3/4" CPI™ Compression	.594	15.1	6.01	0.38	4.22	107.2	2.59	65.8	1.375	34.9	1.125	28.6
16A-C16L	1" A-LOK® Compression	1" A-LOK® Compression	.656	16.7	6.56	0.27	4.63	117.6	2.53	64.3	1.625	41.3	1.500	38.1
16F-C16L	1" Female NPT	1" Female NPT	.656	16.7	6.56	0.27	4.84	122.9	-	-	1.625	41.3	-	-
16F5-C16L	1" Male SAE	1" Male SAE	.656	16.7	6.56	0.27	4.10	104.1	2.64	67.1	1.625	41.3	-	-
16G5-C16L	1" Female SAE	1" Female SAE	.656	16.7	6.56	0.27	4.84	122.9	-	-	1.625	41.3	-	-
16KF-C16L	1" Female BSP/ISO Tapered	1" Female BSP/ISO Tapered	.656	16.7	6.56	0.27	4.84	122.9	-	-	1.625	41.3	-	-
16KM-C16L	1" Male BSP/ISO Tapered	1" Male BSP/ISO Tapered	.656	16.7	6.56	0.27	4.52	114.8	2.64	67.1	1.625	41.3	-	-
16M-C16L	1" Male NPT	1" Male NPT	.656	16.7	6.56	0.27	4.52	114.8	2.63	66.8	1.625	41.3	-	-
16L-C16L	1" Seal-Lok®	1" Seal-Lok®	.656	16.7	6.56	0.27	3.83	97.3	2.45	62.2	1.625	41.3	-	-
16TA-C16L	1" Tube Adapter	1" Tube Adapter	.656	16.7	6.56	0.27	5.11	129.8	2.52	64.0	1.625	41.3	-	-
16Z-C16L	1" CPI™ Compression	1" CPI™ Compression	.656	16.7	6.56	0.27	4.63	117.6	2.53	64.3	1.625	41.3	1.500	38.1
M25A-C16L	25mm A-LOK® Compression	25mm A-LOK® Compression	.656	16.7	6.56	0.27	4.74	120.4	2.64	67.1	1.625	41.3	1.496	38.0
M25Z-C16L	25mm CPI™ Compression	25mm CPI™ Compression	.656	16.7	6.56	0.27	4.74	120.4	2.64	67.1	1.625	41.3	1.496	38.0
16M16A-C16L	1" Male NPT	1" A-LOK® Compression	.656	16.7	6.56	0.27	4.58	116.3	2.59	65.8	1.625	41.3	1.500	38.1
16M16F-C16L	1" Male NPT	1" Female NPT	.656	16.7	6.56	0.27	4.68	118.9	3.73	94.7	1.625	41.3	-	-
16M16Z-C16L	1" Male NPT	1" CPI™ Compression	.656	16.7	6.56	0.27	4.58	116.3	2.59	65.8	1.625	41.3	1.500	38.1

Pressure Rating and Tubing Selection: For working pressures of A-LOK® and CPI™ tube connections, please see the Instrument Tubing Selection Guide (Bulletin 4200-TS), found in the Technical Section of the Parker Instrumentation Process Control Binder, or the Parker Instrument Tube Fitting Installation Manual (Bulletin 4200-B4).

For working pressures of valves with external or internal pipe threads, please see Catalog 4260, Instrumentation Pipe Fittings.

\* Tested in accordance with ISA S75.02. Gas flow will be choked when  $P_1 - P_2 / P_1 = X_T$ .

† For CPI™ and A-LOK®, dimensions are measured with nuts in the finger tight position.



# C Series Check Valves

## How to Order

Dimensions in inches (millimeters) are for reference only, subject to change.

The correct part number is easily derived from the following example and ordering chart. The six product characteristics required are coded as shown in the chart.

**Example 1** below describes a C Series Check Valve with 3/4" CPI™ compression inlet and outlet ports, a 5 psi cracking pressure, nitrile seal and brass body construction.

**Example 2** below describes a C Series Check Valve with a 1" male NPT inlet port and a 1" A-LOK® outlet port, a 10 psi cracking pressure, neoprene seal and stainless steel body construction.

**Example 1:** 12Z-C12L-5-BN-B (shown in the part number blocks below)

**Example 2:** 16M16A-C16L-10-NE-SS

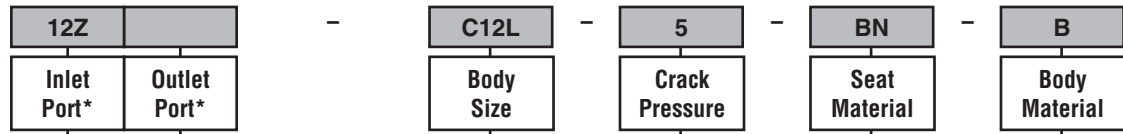

Inlet Port*				Outlet Port*				Body Size	Crack Pressure	Seat Material	Body Material						
2A	2G5	2M	M3A	2A	2G5	2M	M3A	C2L	1/3 psi	Blank	Fluorocarbon	B	Brass				
2F	2KF	2TA	M3Z	2F	2KF	2TA	M3Z		1 psi					BN	Nitrile	SS	316
2F5	2KM	2Z		2F5	2KM	2Z			5 psi								
4A	4KF	4Q	M6A	4A	4KF	4Q	M6A	10 psi	NE	Propylene	Rubber						
4F	4KM	4TA	M6Z	4F	4KM	4TA	M6Z	25 psi				**T	PTFE				
4F5	4L	4V		4F5	4L	4V		50 psi						***KZ	Highly Fluorinated	Rubber	
4G5	4M	4Z		4G5	4M	4Z		75 psi	***	Not available on C2 series.							
6A	6KF	6Q	M8Z	6A	6KF	6Q	M8Z	100 psi			C8L	C8L	C8L				
6F	6KM	6TA	M10A	6F	6KM	6TA	M10A	C6L						C6L	C6L		
6F5	6L	6Z	M10Z	6F5	6L	6Z	M10Z		C12L	C12L						C12L	
6G5	6M	M8A		6G5	6M	M8A					C16L	C16L	C16L				
8A	8KF	8Q	M12A	8A	8KF	8Q	M12A	C12L						C12L	C12L		
8F	8KM	8TA	M12Z	8F	8KM	8TA	M12Z		C16L	C16L						C16L	
8F5	8L	8V		8F5	8L	8V					C16L	C16L	C16L				
8G5	8M	8Z		8G5	8M	8Z		C16L						C16L	C16L		
12A	12KF	12Q	M20A	12A	12KF	12Q	M20A		C16L	C16L						C16L	
12F	12KM	12TA	M20Z	12F	12KM	12TA	M20Z				C16L	C16L	C16L				
12F5	12L	12V	M22A	12F5	12L	12V	M22A	C16L						C16L	C16L		
12G5	12M	12Z	M22Z	12G5	12M	12Z	M22Z		C16L	C16L						C16L	
16A	16G5	16L	16Z	16A	16G5	16L	16Z				C16L	C16L	C16L				
16F	16KF	16M	M25A	16F	16KF	16M	M25A	C16L						C16L	C16L		
16F5	16KM	16TA	M25Z	16F5	16KM	16TA	M25Z		C16L	C16L						C16L	

\*If the inlet and outlet ports are the same, eliminate the outlet port designator.

## Options

**Oxygen Cleaning** – Add the suffix **-C3** to the end of the part number to receive filters cleaned and assembled for oxygen service in accordance with Parker specification ES8003. **Example:** 4A-C4L-1-BN-SS-C3

**Laser Weld** – Add the suffix **-LW** to the end of the part number to receive tamper-resistant stainless steel filters. **Example:** 2F-C2L-1-SS-LW

**NGV Certification** – To receive valves approved and certified by CSA America, Inc, ECE R110, and ISO 15500 for use on natural gas vehicles, please contact the Instrumentation Products Division or your local authorized Parker distributor.

# C Series Check Valves

## Kit Information

To order repair kits for the C Series Check Valves simply fill in the designators from the chart below.

Size	Crack Pressure	Seat Material
C2	1/3 psi	V Fluorocarbon Rubber
C4	1 psi	BN Nitrile
C6	5 psi	EPR Ethylene Propylene Rubber
C8	10 psi	NE Neoprene Rubber
C12	25 psi	*T PTFE
C16	75 psi	KZ Highly Fluorinated Fluorocarbon
	100 psi	

\*PTFE kits can only be used to replace factory installed PTFE seats. It cannot be interchanged with seats of any other material.

**Examples:** KIT-C8-10-V, KIT-C16-100-BN

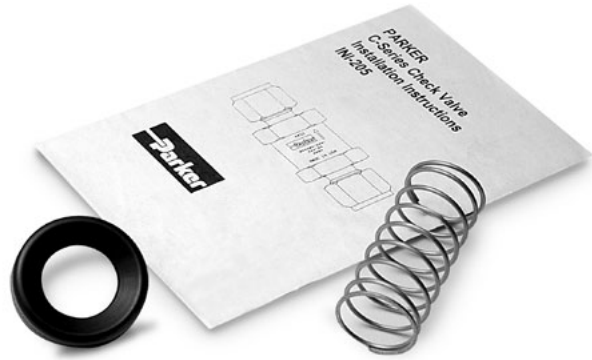

### Check Valve Kits Contain:

- Seat
- Spring
- Instructions