



---

# AC10

Frames 1 - 5

## Product Manual

HA502320U001 Issue 2

2014 Parker Hannifin Manufacturing Ltd.

All rights strictly reserved. No part of this document may be stored in a retrieval system, or transmitted in any form or by any means to persons not employed by a Parker SSD Drives company without written permission from Parker SSD Drives, a division of Parker Hannifin Ltd. Although every effort has been taken to ensure the accuracy of this document it may be necessary, without notice, to make amendments or correct omissions. Parker SSD Drives cannot accept responsibility for damage, injury, or expenses resulting therefrom.

### WARRANTY

The general terms and conditions of sale of goods and/or services of Parker Hannifin Europe Sarl, Luxembourg, Switzerland Branch, Etoy, apply to this product unless otherwise agreed. The terms and conditions are available on our website [www.parker.com/terms andconditions/switzerland](http://www.parker.com/terms andconditions/switzerland)



**FAILURE OR IMPROPER SELECTION OR IMPROPER USE OF  
THE PRODUCTS DESCRIBED HEREIN OR RELATED ITEMS  
CAN CAUSE DEATH, PERSONAL INJURY AND PROPERTY  
DAMAGE.**

This document and other information from Parker-Hannifin Corporation, its subsidiaries and authorized distributors provide product or system options for further investigation by users having technical expertise.

The user, through its own analysis and testing, is solely responsible for making the final selection of the system and components and assuring that all performance, endurance, maintenance, safety and warning requirements of the application are met. The user must analyze all aspects of the application, follow applicable industry standards, and follow the information concerning the product in the current product catalog and in any other materials provided from Parker or its subsidiaries or authorized distributors.

To the extent that Parker or its subsidiaries or authorized distributors provide component or system options based upon data or specifications provided by the user, the user is responsible for determining that such data and specifications are suitable and sufficient for all applications and reasonably foreseeable uses of the components or systems.



# Safety

## Safety Information



## Requirements

**IMPORTANT:** *Please read this information BEFORE installing the equipment.*

### Intended Users

This manual is to be made available to all persons who are required to install, configure or service equipment described herein, or any other associated operation.

The information given is intended to highlight safety issues, EMC considerations, and to enable the user to obtain maximum benefit from the equipment.

Complete the following table for future reference detailing how the unit is to be installed and used.

The information given is intended to highlight safety issues, and to enable the user to obtain maximum benefit from the equipment.

INSTALLATION DETAILS	
<b>Model Number</b> <i>(see product label)</i>	
<b>Where installed</b> <i>(for your own information)</i>	
<b>Unit used as a:</b> <i>(refer to Certification for the Inverter)</i>	<input type="checkbox"/> Component <input type="checkbox"/> Relevant Apparatus
<b>Unit fitted:</b>	<input type="checkbox"/> Wall-mounted <input type="checkbox"/> Enclosure

### Application Area

The equipment described is intended for industrial motor speed control utilising AC induction motors.

### Personnel

Installation, operation and maintenance of the equipment should be carried out by competent personnel. A competent person is someone who is technically qualified and familiar with all safety information and established safety practices; with the installation process, operation and maintenance of this equipment; and with all the hazards involved.

### Product Warnings

 <b>DANGER</b> Risk of electric shock	 <b>WARNING</b> Hot surfaces	 <b>CAUTION</b> Refer to documentation	 <b>EARTH/GROUND</b> Protective Conductor Terminal
-----------------------------------------------------------------------------------------------------------------------------	--------------------------------------------------------------------------------------------------------------------	------------------------------------------------------------------------------------------------------------------------------	--------------------------------------------------------------------------------------------------------------------------------------------

## Hazards

### **DANGER! - Ignoring the following may result in injury**

8. This equipment can endanger life by exposure to rotating machinery and high voltages.
9. The equipment must be permanently earthed due to the high earth leakage current, and the drive motor must be connected to an appropriate safety earth.
10. Ensure all incoming supplies are isolated before working on the equipment. Be aware that there may be more than one supply connection to the drive.
11. There may still be dangerous voltages present at power terminals (motor output, supply input phases, DC bus and the brake, where fitted) when the motor is at standstill or is stopped.
12. For measurements use only a meter to IEC 61010 (CAT III or higher). Always begin using the highest range. CAT I and CAT II meters must not be used on this product.
13. Allow at least 5 minutes for the drive's capacitors to discharge to safe voltage levels (<50V). Use the specified meter capable of measuring up to 1000V dc & ac rms to confirm that less than 50V is present between all power terminals and earth.
14. Unless otherwise stated, this product must NOT be dismantled. In the event of a fault the drive must be returned. Refer to "Routine Maintenance and Repair".

### **WARNING! - Ignoring the following may result in injury or damage to equipment**

#### **SAFETY**

**Where there is conflict between EMC and Safety requirements, personnel safety shall always take precedence.**

- Never perform high voltage resistance checks on the wiring without first disconnecting the drive from the circuit being tested.
- Whilst ensuring ventilation is sufficient, provide guarding and /or additional safety systems to prevent injury or damage to equipment.
- When replacing a drive in an application and before returning to use, it is essential that all user defined parameters for the product's operation are correctly installed.
- All control and signal terminals are SELV, i.e. protected by double insulation. Ensure all external wiring is rated for the highest system voltage.
- Thermal sensors contained within the motor must have at least basic insulation.
- All exposed metalwork in the Inverter is protected by basic insulation and bonded to a safety earth.
- RCDs are not recommended for use with this product but, where their use is mandatory, only Type B RCDs should be used.

#### **EMC**

- In a domestic environment this product may cause radio interference in which case supplementary mitigation measures may be required.
- This equipment contains electrostatic discharge (ESD) sensitive parts. Observe static control precautions when handling, installing and servicing this product.
- This is a product of the restricted sales distribution class according to IEC 61800-3. It is designated as "professional equipment" as defined in EN61000-3-2. Permission of the supply authority shall be obtained before connection to the low voltage supply.

### **CAUTION!**

#### **APPLICATION RISK**

- The specifications, processes and circuitry described herein are for guidance only and may need to be adapted to the user's specific application. We can not guarantee the suitability of the equipment described in this Manual for individual applications.

## Contents

---

<i>Contents</i>	<i>Page</i>
Chapter 1 Introduction .....	1-1
1. Understanding the Product Code .....	1-1
2. Nameplate Example .....	1-1
3. Product Range .....	1-2
Chapter 2 Product Overview .....	2-1
2.1 Designed Standards for Implementation .....	2-1
2.2 Control Features .....	2-2
Chapter 3 Installation .....	3-1
3.1 Equipment Precautions .....	3-1
Chapter 4 Maintenance .....	4-1
4.1 Periodic checking .....	4-1
4.2 Storage .....	4-1
4.3 Daily Maintenance .....	4-1
Chapter 5 The Keypad .....	5-1
5.1 The Display .....	5-1
5.2 Remote-control .....	5-1
5.2.1 Port of control panel .....	5-2
Chapter 6 The Menu Organisation .....	6-1
6.1 Parameters Setting .....	6-1
6.2 Function Codes Switchover in/between Code-Groups .....	6-2
6.3 Panel Display .....	6-3
Chapter 7 Installation & Connection .....	7-1
7.1 Installation .....	7-1
7.2 Connection .....	7-2
7.3 Measurement of main circuit voltages, currents and powers .....	7-3
7.4 Functions of control terminals .....	7-5
7.5 Wiring for digital input terminals: .....	7-6
7.5.1 Wiring for positive source electrode (NPN mode) .....	7-6
7.5.2 Wiring for active source electrode .....	7-6
7.5.3 Wiring for positive drain electrode (PNP mode) .....	7-6
7.5.4 Wiring for active drain electrode (PNP mode) .....	7-7
7.6 Connection Overview .....	7-8
7.7 Basic methods of suppressing the noise .....	7-9
7.7.1 Noise propagation paths and suppressing methods .....	7-9
7.7.2 Basic methods of suppressing the noise .....	7-10
7.7.3 Field Wire Connections .....	7-11
7.7.4 Earthing .....	7-11
7.7.5 Leakage Current .....	7-12
7.7.6 Electrical Installation of the Drive .....	7-12
7.7.7 Application of Power Line Filter .....	7-13
Chapter 8 Operation and Simple Running .....	8-1
8.1 Basic Conception .....	8-1

# Contents

<i>Contents</i>	<i>Page</i>
8.1.1 Control Mode.....	8-1
8.1.2 Mode of Torque Compensation.....	8-1
8.1.3 Mode of frequency setting.....	8-1
8.1.4 Mode of controlling for running command.....	8-1
8.1.5 Operating status of inverter.....	8-1
8.2 Keypad Panel and Operation Method.....	8-2
8.2.1 Method of operating the keypad panel.....	8-2
8.2.2 Operation Process of Setting the Parameters using the Keypad Panel 8-2	
8.2.3 Setting the Parameters.....	8-2
8.2.4 Switching and displaying of status parameters.....	8-2
8.2.5 Switching of the parameters displayed under stopped status.....	8-3
8.2.6 Switching of the parameters displayed under running status.....	8-3
8.2.7 Operation process of measuring motor parameters.....	8-3
8.2.8 Operation process of simple running.....	8-4
8.3 Illustration of Basic Operation.....	8-5
8.3.1 Frequency setting, start, forward running and stop using the keypad panel 8-5	
8.3.2 Setting the frequency using the keypad panel, and starting, forward and reverse running, and stopping inverter through control terminals.....	8-6
8.3.3 Operation process of jogging operation using the keypad panel.....	8-7
8.3.4 Setting the frequency with analog terminal and controlling the operation with control terminals.....	8-8
Chapter 9 Function Parameters.....	9-1
9.1 Basic Parameters.....	9-1
9.2 Operation Control.....	9-11
9.3 Multifunctional Input and Output Terminals.....	9-18
9.3.1 Digital multifunctional output terminals.....	9-18
9.3.2 Digital multifunctional input terminals.....	9-21
9.3.3 Analog input monitoring.....	9-25
9.4 Analog Input and Output.....	9-26
9.5 Multi-stage Speed Control.....	9-30
9.6 Auxiliary Functions.....	9-32
9.7 Malfunction and Protection.....	9-36
9.8 Motor Parameters.....	9-40
9.9 Communication Parameter.....	9-43
9.10 PID Parameters.....	9-43
9.11 Torque control parameters.....	9-45
Chapter 10 Troubleshooting.....	10-1
Chapter 11 Technical Specifications.....	11-1
11.1 Selection of Braking Resistance.....	11-1
Chapter 12 Modbus Communication.....	12-1



## Contents

---

<i>Contents</i>	<i>Page</i>
12.1 General.....	12-1
12.2 Modbus Protocol .....	12-1
12.2.1 Transmission mode .....	12-1
12.2.2 ASCII Mode .....	12-1
12.2.3 RTU Mode .....	12-1
12.3 Baud rate .....	12-1
12.4 Frame structure: .....	12-2
12.5 Error Check .....	12-2
12.5.1 ASCII mode .....	12-2
12.5.2 RTU Mode .....	12-2
12.5.3 Protocol Converter .....	12-3
2.6 Command Type & Format.....	12-3
12.6.1 Address and meaning .....	12-3
12.6.2 Running Status Parameters .....	12-4
12.6.3 Control commands .....	12-5
12.6.4 Illegal Response When Reading Parameters .....	12-6
12.7 Function Codes Related to Communication .....	12-7
12.8 Physical Interface .....	12-8
12.8.1 Interface instruction .....	12-8
12.8.2 Structure of Field Bus .....	12-8
12.9 Grounding and Terminal .....	12-8
12.9.1 Examples .....	12-9
Chapter 13 The Default Applications .....	13-1
13.1 Application 1: Basic Speed Control.....	13-2
13.2 Application 2 : Auto/Manual Control .....	13-4
13.3 Application 3: Preset Speeds .....	13-6
13.4 Application 4 : Raise/Lower Secondary .....	13-8
13.5 Application 5: PID .....	13-10
Chapter 14 Compliance .....	14-1
14.1 Applicable Standards .....	14-1
14.2 North American & Canadian Compliance Information .....	14-2
14.2.1 UL Standards.....	14-2
14.4.2 UL Standards Compliance.....	14-2
14.2 Declaration .....	14-6
Chapter 15 Parameter Reference .....	15-1
Basic parameters: F100-F160.....	15-1
Running control mode: F200-F230 .....	15-4
Multifunctional Input and Output Terminals: F300-F330 .....	15-6
Analog Input and Output: F400-F480.....	15-8
Multi-stage Speed Control: F500-F580.....	15-10
Auxiliary Functions: F600-F670 .....	15-11
Timing Control and Protection: F700-F770 .....	15-12

# Contents

---

<i>Contents</i>	<i>Page</i>
Motor parameters: F800-F830 .....	15-14
Communication parameter: F900-F930 .....	15-15
PID parameters: FA00-FA80 .....	15-15
Torque control parameters: FC00-FC40 .....	15-16

## Chapter 1 Introduction

This manual offers an introduction to the installation and connection for the AC10 series. Parameters setting, software and operations are also covered in this manual.

### 1. Understanding the Product Code

#### Model Number

The unit is fully identified using a four block alphanumeric code which records how the drive was calibrated, and its various settings when dispatched from the factory. This can also be referred to as the Product Code.

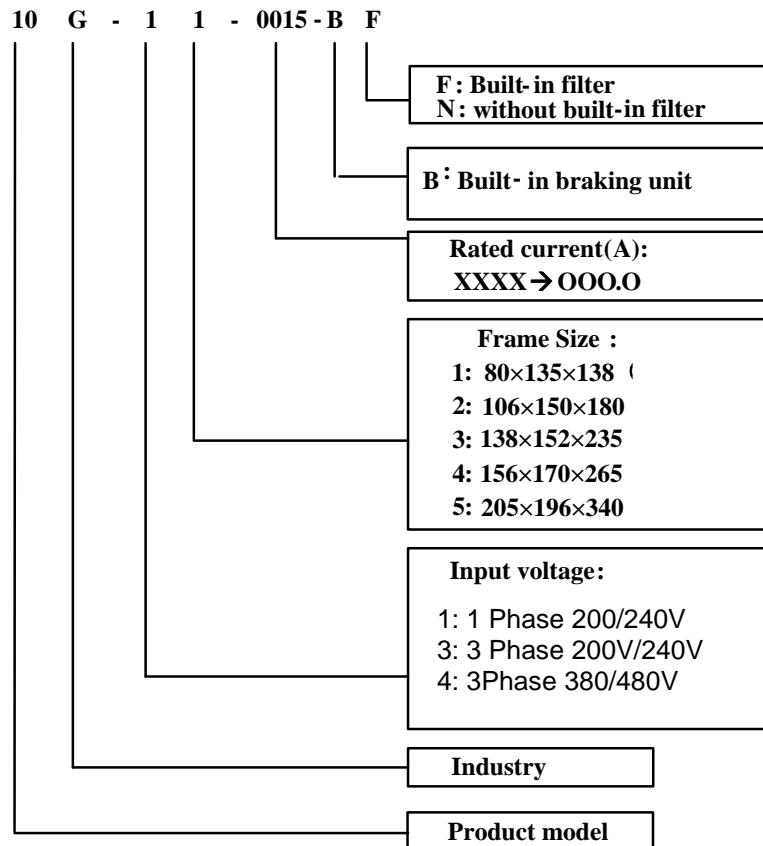

### 2. Nameplate Example

This nameplate shows the product as an AC10 series 2.2 kW inverter with 3-phase input.

3Ph: three-phase input; 380-480V, 50/60Hz: input voltage range and rated frequency.

3Ph: 3-phase output; 6.5A, 2.2kW: rated output current and power;



# 1-2 Introduction

## 3. Product Range

Supply	Part number	kW	Input current (A)	Output Current (A)	Input protection current
1Ph 220V	10G-11-0015-XX	0.2	4.0	1.5	6.0
	10G-11-0025-XX	0.37	6.1	2.5	10.0
	10G-11-0035-XX	0.55	8.9	3.5	14.0
	10G-11-0045-XX	0.75	11.4	4.5	18.1
	10G-12-0050-XX	1.1	16.1	5	24.5
	10G-12-0070-XX	1.5	16.8	7	25.2
	10G-12-0100-XX	2.2	21.0	10	32.0
3Ph 220V	10G-31-0015-XX	0.2	2.2	1.5	5.0
	10G-31-0025-XX	0.37	4.3	2.5	8.2
	10G-31-0035-XX	0.55	6.1	3.5	10.0
	10G-31-0045-XX	0.75	7.6	4.5	11.5
	10G-32-0050-XX	1.1	11.8	5	18.0
	10G-32-0070-XX	1.5	12.0	7	18.2
	10G-32-0100-XX	2.2	14.3	10	21.5
3Ph 400V	10G-41-0006-XX	0.2	1.2	0.6	2.5
	10G-41-0010-XX	0.37	2.2	1	5.0
	10G-41-0015-XX	0.55	3.6	1.5	5.5
	10G-42-0020-XX	0.75	4.1	2	6.5
	10G-42-0030-XX	1.1	6.0	3	10.2
	10G-42-0040-XX	1.5	6.9	4	11.0
	10G-42-0065-XX	2.2	9.6	6.5	15.0
	10G-43-0080-XX	3.7	11.6	8	18.0
	10G-43-0090-XX	4	13.6	9	21.0
	10G-43-0120-XX	5.5	18.8	12	29.0
	10G-44-0170-XX	7.5	22.1	17	34.0
	10G-44-0230-XX	11	30.9	23	46.5
	10G-45-0320-XX	15	52	32	80.0
	10G-45-0380-XX	18.5	58	38	90
	10G-45-0440-XX	22	66	44	100

## Chapter 2 Product Overview

The external structure of AC10 series inverter has a plastic housing.

Illustrated is the AC10G-12-0050-XX

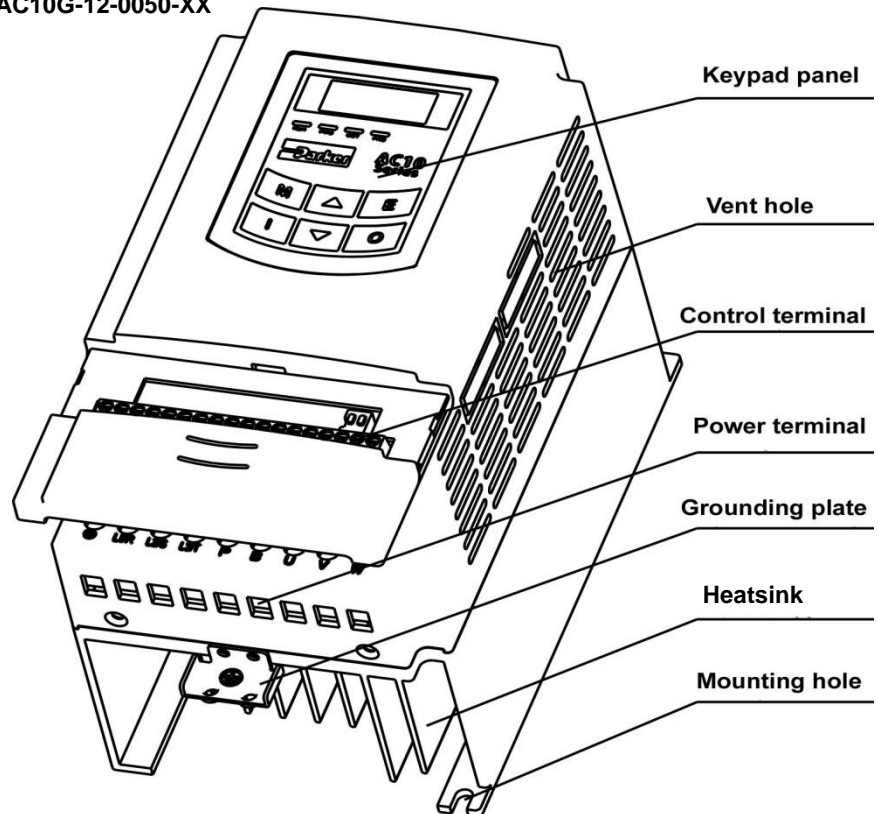

### 2.1 Designed Standards for Implementation

IEC/EN 61800-5-1: 2007 Adjustable speed electrical power drive systems safety requirements.

IEC/EN 61800-3: 2004 Adjustable speed electrical power drive systems-Part 3: EMC product standard including specific test methods.

## 2-2 Product Overview

### 2.2 Control Features

Table 2-1 Technical Specification for AC10 series Inverters

Input	Rated Voltage Range	3-phase 380-480V (+10%, -15%) 1-phase 220-240V ±15% 3-phase 220-240V ±15%
	Rated Frequency	50/60Hz
Output	Rated Voltage Range	3-phase 0-INPUT (V)
	Frequency Range	0.50~590.0Hz
Control Mode	Carrier Frequency	2000~10000Hz; Fixed carrier-wave and random carrier-wave can be selected by F159.
	Input Frequency Resolution	Digital setting: 0.01Hz, analog setting: max frequency × 0.1%
	Control Mode	Sensorless vector control (SVC), V/Hz control
	Start Torque	0.5 Hz / 150% (SVC)
	Speed-control Scope	1:100 (SVC)
	Steady Speed Precision	±0.5% (SVC)
	Torque Control Precision	±5% (SVC)
	Overload Capacity	150% rated current, 60 seconds.
	Torque Elevating	Auto torque promotion, manual torque promotion includes 1-20 curves.
	VVVF Curve	3 kinds of modes: quadratic type, square type and user-defined V/Hz curve.
	DC Braking	DC braking frequency: 0.2-5.00 Hz, braking time: 0.00~30.00s
	Jogging Control	Jogging frequency range: min frequency~ max frequency, jogging acceleration/deceleration time: 0.1~3000.0s
	Auto Circulating Running and multi-stage speed running	Auto circulating running or terminals control can realize 15-stage speed running.
Built-in PID adjusting	Easy to realize a system for process closed-loop control	
Auto voltage regulation (AVR)	When source voltage changes, the modulation rate can be adjusted automatically, so that the output voltage is unchanged.	
Operation Function	Frequency Setting	Analog signal (0~5V, 0~10V, 0~20mA); keypad (terminal)▲ / ▼ keys, external control logic and automatic circulation setting.
	Start/Stop Control	Terminal control, keypad control or communication control.
	Running Command Channels	3 kinds of channels from keypad panel, control terminals or RS485
	Frequency Source	Frequency sources: User terminals, from the MMI or via RS485.
	Auxiliary frequency Source	5 options
Optional	Built-in EMC filter, built-in braking unit	
Protection Function	Input phase loss, Output phase loss, input under-voltage, DC over-voltage, over-current, inverter over-load, motor over-load, current stall, over-heat, external disturbance, analog line disconnected.	
MMI Display	LED seven segment display showing output frequency, rotate-speed (rpm), output current, output voltage, DC bus voltage, PID feedback value, PID setting value, linear-velocity, types of faults, and parameters for the system and operation; LED indicators showing the current working status of inverter.	
Environment Conditions	Equipment Location	In an indoor location, Prevent exposure from direct sunlight, from dust, from caustic gases, flammable gases, steam or other contamination.
	Environment Temperature	-10°C~+40°C (50°C with derating)
	Environment Humidity	Below 90% (non condensing)
	Vibration Strength	Below 0.5g
	Height above sea level	1000m or below (3000m with derating)
Environment	3C3 conformance	
Protection level	IP20	
Applicable Motor	0.2~22kW	

## Chapter 3 Installation

**IMPORTANT** Read Chapter 14 “Compliance” before installing this unit.

### 3.1 Equipment Precautions

- Check for signs of transit damage.
- Check the product code on the rating label conforms to your requirements.
- Installation and application environment should be free of rain, drips, steam, dust and oily dirt; without corrosive or flammable gases or liquids, metal particles or metal powder. Environment temperature within the scope of  $-10^{\circ}\text{C} \sim +50^{\circ}\text{C}$  ( $40^{\circ}\text{C}$  without derating)
- Please install inverter away from combustibles.
- Do not drop anything into the inverter.
- The reliability of inverters relies heavily on the temperature. As the surrounding temperature increases by 10 degrees the inverter life will be halved.
- The inverter is designed to be installed in a control cabinet, smooth ventilation should be ensured and the inverter should be installed vertically. If there are several inverters in one cabinet, in order to ensure ventilation, install inverters side by side. If it is necessary to install several inverters above each other, you need additional ventilation.
- Never touch the internal elements for 15 minutes after power goes off. Wait until it is completely discharged.
- Input terminals R, S and T are connected to power supply of 400V while output terminals U, V and W are connected to motor.
- Proper grounding should be ensured with grounding resistance not exceeding  $4\Omega$ ; separate grounding is required for motor and inverter. Grounding with series connection is forbidden.
- There should be separate wiring between control loop and power loop to avoid any possible interference.
- Cable length should be minimized to limit common mode interference.
- If circuit breaker or contactor needs to be connected between the drive and the motor, be sure to operate these circuit breakers or contactor when the drive has no output, to avoid damaging the drive.
- Before using the drive, the insulation of the motors must be checked, especially if it is used for the first time or if it has been stored for a long time. This is to reduce the risk of the drive being damaged by poor insulation of the motor.
- Do not connect any varistor or capacitor to the output terminals of the drive because the drive's output voltage waveform is pulse wave, otherwise tripping or damaging of components may occur.

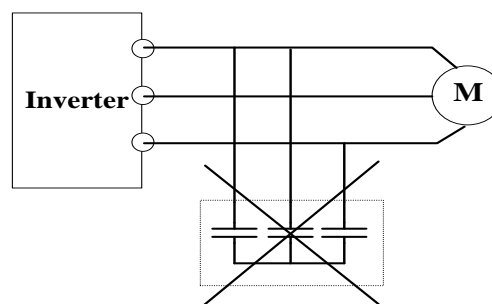
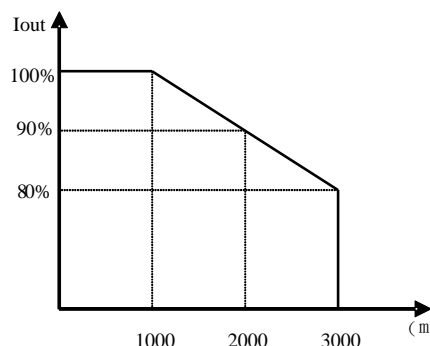

Figure 3-1 Capacitors are prohibited to be used

- Derating must be drive is installed at than 1000m). This is effect of drive is the thin air, as



considered when the high altitude (greater because the cooling deteriorated due to shown in Figure 3-2

## 3-2 Installation

that indicates the relationship between the elevation and rated current of the drive.

Figure 3-2 Derating drive's output current with altitude

- Temperature derating

		Power of drive (kW)														
		0.2	0.37	0.55	0.75	1.1	1.5	2.2	3.7	4	5.5	7.5	11	15	18.5	22
Power of Motor (kW)	0.2	40 °C	50 °C	50 °C	50 °C	50 °C	50 °C	50 °C	50 °C	50 °C	50 °C	50 °C	50 °C	50 °C	50 °C	50 °C
	0.37	30 °C	40 °C	50 °C	50 °C	50 °C	50 °C	50 °C	50 °C	50 °C	50 °C	50 °C	50 °C	50 °C	50 °C	50 °C
	0.55	20 °C	30 °C	40 °C	50 °C	50 °C	50 °C	50 °C	50 °C	50 °C	50 °C	50 °C	50 °C	50 °C	50 °C	50 °C
	0.75		20 °C	30 °C	40 °C	45 °C	50 °C	50 °C	50 °C	50 °C	50 °C	50 °C	50 °C	50 °C	50 °C	50 °C
	1.1				30 °C	40 °C	45 °C	50 °C	50 °C	50 °C	50 °C	50 °C	50 °C	50 °C	50 °C	50 °C
	1.5					30 °C	40 °C	50 °C	50 °C	50 °C	50 °C	50 °C	50 °C	50 °C	50 °C	50 °C
	2.2						35 °C	40 °C	50 °C	50 °C	50 °C	50 °C	50 °C	50 °C	50 °C	50 °C
	3.7							25 °C	40 °C	50 °C	50 °C	50 °C	50 °C	50 °C	50 °C	50 °C
	4								30 °C	40 °C	50 °C	50 °C	50 °C	50 °C	50 °C	50 °C
	5.5									30 °C	40 °C	50 °C	50 °C	50 °C	50 °C	50 °C
	7.5										25 °C	40 °C	50 °C	50 °C	50 °C	50 °C
	11											20 °C	40 °C	50 °C	50 °C	50 °C
	15													40 °C	50 °C	50 °C
	18.5														40 °C	50 °C
22															40 °C	



## Chapter 4 Maintenance

### 4.1 Periodic Checking

Cooling fan and ventilation channel should be cleaned regularly to check it is clear; remove any dust accumulated in the inverter on a regular basis.

Check inverter's input and output wiring and wiring terminals regularly and check if wirings are ageing.

Check whether screws on each terminals are fastened.

### 4.2 Storage

Please put the inverter in the packing case of manufacture.

If inverter is stored for long time, charge the inverter within half a year to prevent the electrolytic capacitors being damaged. The charging time should be longer than 5 hours.

### 4.3 Daily Maintenance

Environment temperature, humidity, dust and vibration would decrease the life of inverter. Daily maintenance is necessary to inverters.

Daily inspecting:

Inspecting for noise of motor when it is working.

Inspecting for abnormal vibration of motor when it is working.

Inspecting for the installing environment of inverter.

Inspecting for the fan and inverter temperature.

Daily cleaning:

Keep the inverter clean. Clean surface dust of inverter to prevent dust, metal powder, oily dirt and water from dropping into the inverter.



# 5-1 The Keypad

## Chapter 5 The Keypad

### 5.1 The Display

The panel covers three sections: **data display section**, **status indicating section** and **keypad operating section**, as shown in Figure 5-1.

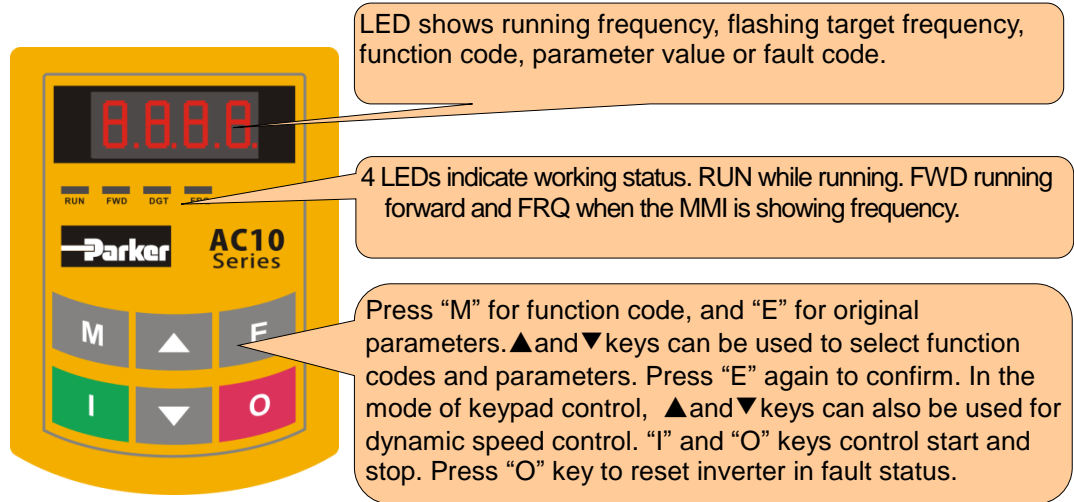

Figure 5-1 Keypad Display

### 5.2 Remote-control

The remote mounted keypad can be ordered as 1001-00-00.

This includes the keypad, cable and mounting brackets.

Layout diagram



Keypad Measurements (Unit:mm)

Code	A	B	C	D	H	Opening size
1001-00-00	124	74	120	70	26	121*71

5.2.1 Port of control panel

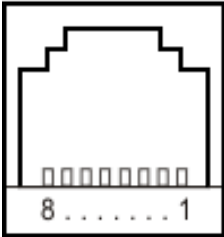

Pins	1	2	3	4	5	6	7	8
8 core	None	5V	Grounding	Grounding	Signal 1	Signal 2	Signal 3	Signal 4







The default length of remote cable is 1m. On the occasion of heavy interference or if remote control cable is longer than 3m, please add magnetic ring on the cable.

# 6-1 The Menu Organisation

## Chapter 6 The Menu Organisation

All keys on the panel are available for user. Refer to Table 6-1 for their functions.















Table 6-1 Uses of Keys

Keys	Names	Remarks
	Menu	To call function code and switch over display mode.
	Enter	To call and save data.
	Up	To increase data (speed control or setting parameters)
	Down	To decrease data (speed control or setting parameters)
	Run	To start inverter
	Stop or Reset	To stop inverter; to reset in fault status; to change function codes in a code group or between two code groups. In the interface of function code, keep pressing "O" key for 3s, inverter will be stopped. (if stop command is controlled by keypad).

### 6.1 Parameters Setting

This inverter has numerous function parameters that the user can modify to effect different modes of operation. The user should be aware that if they set password valid (F107=1), the password must be entered first.

Table 6-2 Steps for Parameters Setting

Steps	Keys	Operation	Display
1		Press "M" key to display function code	
2	 or 	Press "Up" or "Down" to select required function code	
3		Read data set in the function code	
4	 or 	To modify data	
5		Shows corresponding target frequency by flashing after saving the set data	
		Displays the current function code	

The above-mentioned step should be operated when inverter is in stop status.

6.2 Function Codes Switchover in/between Code-Groups

It has more than 300 parameters (function codes) available to user, divided into sections as indicated in Table 6-3.

Table 6-3 Function Code Partition

Group Name	Function Code Range	Group No.	Group Name	Function Code Range	Group No.
Basic Parameters	F100~F160	1	Timing control and protection function	F700~F770	7
Run Control Mode	F200~F280	2	Parameters of the motor	F800~F850	8
Multi-functional input/output terminal	F300~F340	3	Communication function	F900~F930	9
Analog signals and pulse of input/output	F400~F480	4	PID parameter setting	FA00~FA80	10
Multi-stage speed Parameters	F500~F580	5	Torque control	FC00~FC40	11
Subsidiary function	F600~F670	6			

As parameter setting can take time due to numerous function codes, such function is specially designed as “Function Code Switchover in a Code Group or between Two Code-Groups” so that parameters setting becomes convenient and simple.

Press “M” key so that the keypad controller will display function code. If user presses “▲” or “▼” key, the function code will circularly keep increasing or decreasing by degrees within the group; if user presses the “O” key again, the function code will change circularly between two code groups when operating the “▲” or “▼” key, e.g. when function code shows F111 and DGT indicator is on, press “▲”/“▼” key, function code will keep increasing or decreasing by degrees within F100~F160; press “O” key again, DGT indicator will be off. When pressing “▲”/“▼” key, function codes will change circularly among the 10 code-groups, like F211, F311...FA11, F111..., Refer to Figure 6-1 (The flashing “50.00” is indicated the corresponding target frequency values).

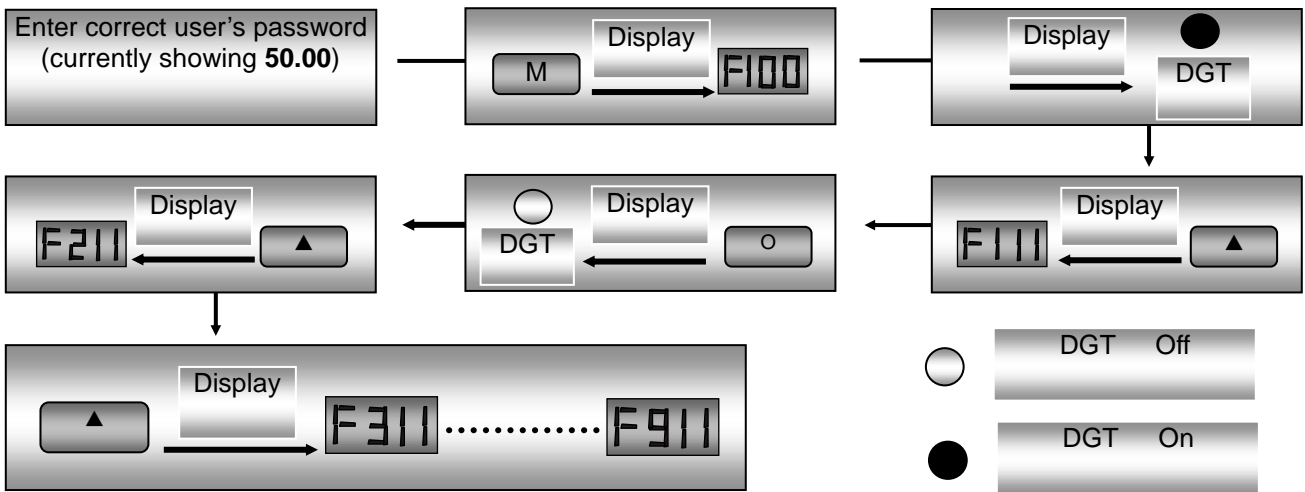

Figure 6-1 Switch over in a Code Group or between Different Code-Groups

# 6-3 The Menu Organisation

## 6.3 Panel Display

Table 6-4 Items and Remarks Displayed on the Panel

Items	Remarks
HF-0	This Item will be displayed when you press “M” in stopping status, which indicates jogging operation is valid. But HF-0 will be displayed only after you change the value of F132.
-HF-	It stands for resetting process and will display target frequency after reset.
OC, OC1, OE, OL1, OL2, OH, LU, PF0, PF1, CE, FL	Fault code, indicating “over-current OC”, “over-current OC1”, “over-voltage”, “inverter over-load”, “motor over-load” “over-heat”, “under-voltage for input”, “phase loss for output”, “phase loss for input” “Communication error”, “Flycatching fault” respectively.
AErr, Err5	Analog line disconnected, PID parameters are set wrong,
ESP	External emergency stop terminal is closed, ESP will be displayed.
F152	Function code (parameter code).
10.00	Indicating inverter’s current running frequency (or rotate speed) and parameter setting values, etc.
<b>50.00</b>	Flashing in stopping status to display target frequency.
0.	Holding time when changing the running direction. When “Stop” or “Free Stop” command is executed, the holding time can be cancelled.
A100、U100	Output current (100A) and output voltage (100V). Keep one digit of decimal when current is below 100A.
b*. *	PID feedback value is displayed.
o*. *	PID given value is displayed.
L***	Linear speed is displayed.
H *	Heat Sink temperature is displayed.





## Chapter 7 Installation & Connection

### 7.1 Installation

Inverter should be installed vertically, as shown in Figure 7-1. Sufficient ventilation space should be ensured in its surrounding.

Clearance dimensions (recommended) are available from Table 7-1 Clearance Dimensions for installing of the inverter. Space between 2 drives 25mm.

Table 7-1 Clearance Dimensions

Model	Clearance Dimensions	
Hanging	A≥150mm	B≥12.5mm

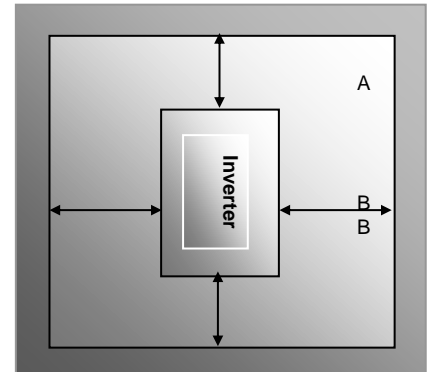
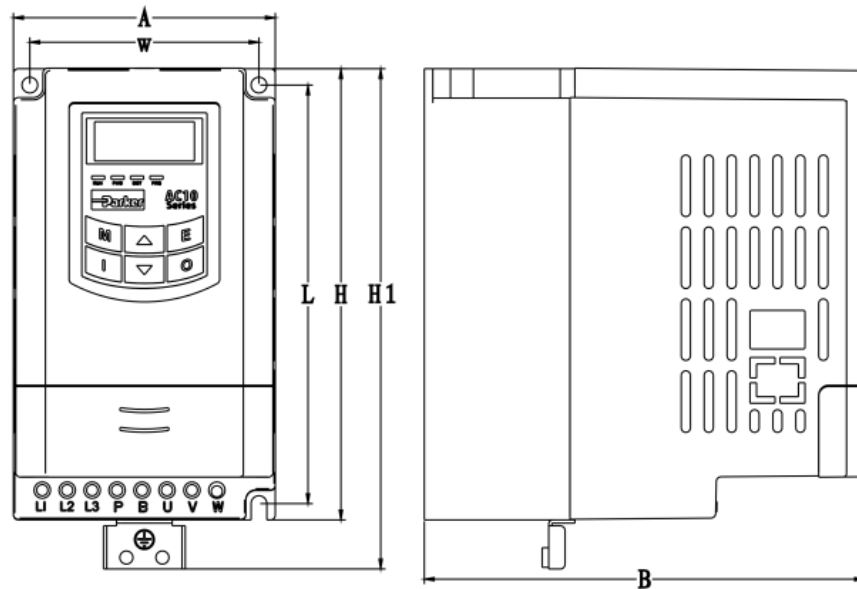

Figure 7-1 Installation Sketch

Frame	External Dimension AxBxH (H1) mm	Mounting Size(WxL)	Mounting Bolt
1	80x135x138 (153)	70x128	M4
2	106x150x180 (195)	94x170	M4
3	138x152 x235 (250)	126x225	M5
4	156x170x265 (280)	146x255	M5
5	205x196 x340 (355)	194x330	M5



Cover Layout

Note:

H is the size of inverter without grounding plate.

H1 is the size of inverter with grounding plate.

# 7-2 Installation & Connection

## 7.2 Connection

Connect R/L1, S/L2 and T/L3 terminals (L1/R and L2/S terminals for single-phase) with power supply,  to grounding, and U, V and W terminals to motor.

Motor shall have to be grounded. Otherwise electrified motor causes interference.

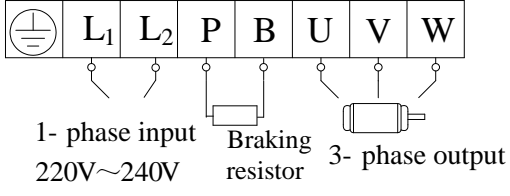
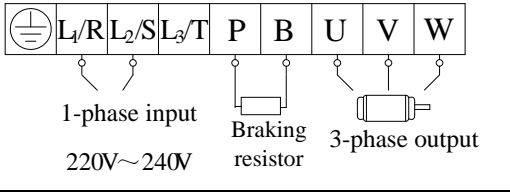
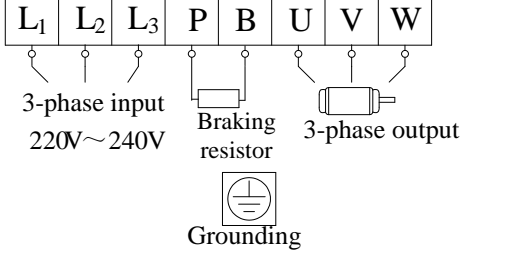
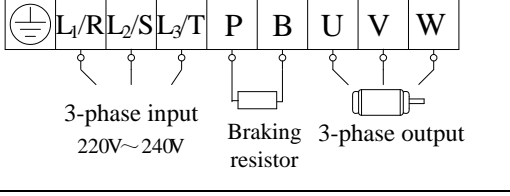
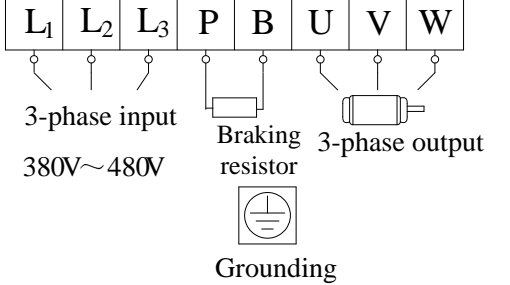
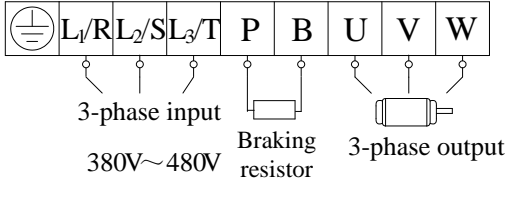
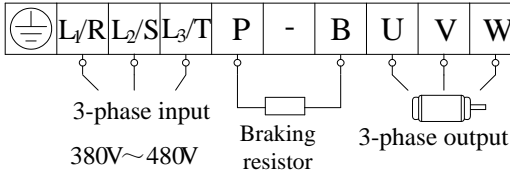
Model	Sketch
1-phase 230V 0.2kW~0.75kW	 <p>1- phase input 220V~240V</p> <p>Braking resistor</p> <p>3- phase output</p>
1-phase 230V 1.1kW~2.2kW	 <p>1- phase input 220V~240V</p> <p>Braking resistor</p> <p>3- phase output</p>
3-phase 230V 0.2kW~0.75kW	 <p>3- phase input 220V~240V</p> <p>Braking resistor</p> <p>3- phase output</p> <p>Grounding</p>
3-phase 230V 1.1kW~2.2kW	 <p>3- phase input 220V~240V</p> <p>Braking resistor</p> <p>3- phase output</p>
3-phase 400V 0.2kW~0.55kW	 <p>3- phase input 380V~480V</p> <p>Braking resistor</p> <p>3- phase output</p> <p>Grounding</p>
3-phase 400V 0.75kW~11kW	 <p>3- phase input 380V~480V</p> <p>Braking resistor</p> <p>3- phase output</p>
3-phase 400V 22kW	 <p>3- phase input 380V~480V</p> <p>Braking resistor</p> <p>3- phase output</p>

## Introduction of terminals of power loop

Terminals	Terminal Marking	Terminal Function Description
Power Input Terminal	R/L1, S/L2, T/L3	Input terminals of three-phase 400V AC voltage (R/L1 and S/L2 terminals for single-phase)
Output Terminal	U, V, W	Inverter power output terminal, connected to motor.
Grounding Terminal		Inverter grounding terminal.
Braking Terminal	P, B	External braking resistor (Note: no Terminals P or B for inverter without built-in braking unit).
	P, -	DC bus-line output External connections to optional braking unit P connected to input terminal "P" or "DC+" of braking unit, - connected to input terminal of braking unit "N" or "DC-".

Control loop terminals as follows:

TA	TB	TC	D01	24V	CM	DI1	DI2	DI3	DI4	DI5	10V	AI1	AI2	GND	AO1	A+	B-
----	----	----	-----	-----	----	-----	-----	-----	-----	-----	-----	-----	-----	-----	-----	----	----

### 7.3 Measurement of Main Circuit Voltages, Currents and Powers

Since the voltages and currents on the inverter power supply and output sides include harmonics, measurement data depends on the instruments used and circuits measured. When instruments for commercial frequency are used for measurement, measure the following circuits with the recommended instruments.

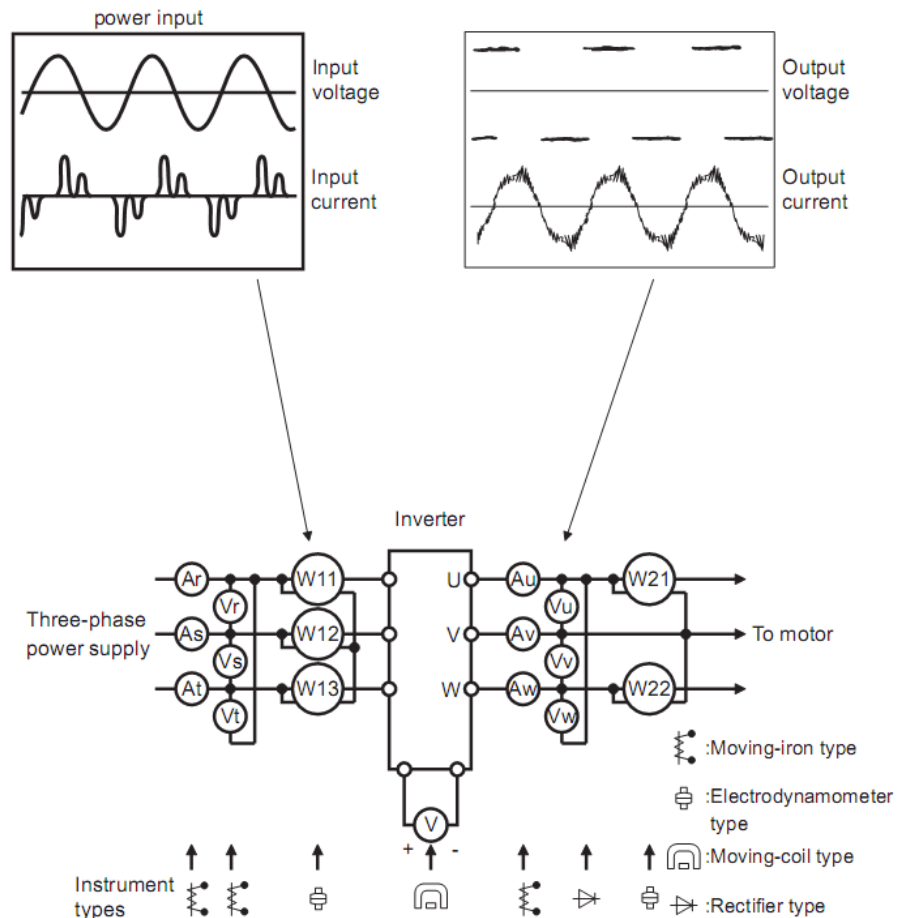

# 7-4 Installation & Connection

Table 7-2

Item	Measuring Point	Measuring Instrument	Remarks (Reference Measurement Value)
Power supply voltage V1	Across R-S,S-T, T-R	Moving-iron type AC voltmeter	400V±15%, 230V±15%
Power supply side current I1	R, S, and T line currents	Moving-iron type AC voltmeter	
Power supply side power P1	At R, S and T, and across R-S, S-T and T-R	Electrodynamic type single-phase wattmeter	P1=W11+W12+W13 (3-wattmeter method)
Power supply side power factor Pf1	Calculate after measuring power supply voltage, power supply side current and power supply side power.[Three phase power supply] $Pf1 = \frac{P1}{\sqrt{3}V1 \times I1} \times 100\%$		
Output side voltage V2	Across U-V, V-W and W-U	Rectifier type AC voltmeter (Moving-iron type cannot measure)	Difference between the phases is within ±1% of the maximum output voltage.
Output side current I2	U, V and W line currents	Moving-iron type AC Ammeter	Current should be equal to or less than rated inverter current. Difference between the phases is 10% or lower of the rated inverter current.
Output side power P2	U, V, W and U-V, V-W,W-U	Electro dynamic type single-phase wattmeter	P2 = W21 + W22 2-wattmeter method
Output side power factor Pf2	Calculate in similar manner to power supply side power factor: $Pf2 = \frac{P2}{\sqrt{3}V2 \times I2} \times 100\%$		
Converter output	Across P+ (P) and -(N)	Moving-coil type (such as multi-meter)	DC voltage, the value is $\sqrt{2} \times V1$
Power supply of control PCB	Across 10V-GND	Moving-coil type (such as multi-meter)	DC10V±0.2V
	Across 24V-CM	Moving-coil type (such as multi-meter)	DC24V±1.5V
Analog output AO1	Across AO1-GND	Moving-coil type (such as multi-meter)	Approx. DC10V at max frequency.
Alarm signal	Across TA/TC Across TB/TC	Moving-coil type (such as multi-meter)	<Normal> <Abnormal> Across TA/TC: Discontinuity Continuity Across TB/TC: Continuity Discontinuity

## 7.4 Functions of Control Terminals

To operate the inverter the user must operate the control terminals correctly and flexibly. The following is a description of the user terminals and any relevant parameters.

Table 7-3 Functions of Control Terminals

Terminal	Type	Description	Function
DO1	Output signal	Multifunctional output terminal 1	When the token function is valid, the value between this terminal and CM is 0V; when the inverter is stopped, the value is 24V.
TA		Relay contact	TC is a common point, TB-TC are normally closed contacts, TA-TC are normally open contacts. The contact capacity is 10A/125VAC, 5A/250VAC, 5A/30VDC.
TB			
TC			
AO1	Running frequency	It is connected with frequency meter, speedometer or ammeter externally, and its minus pole is connected with GND. See F423~F426 for details.	
10V	Analog power supply	Self contained power supply	Internal 10V self-contained power supply of the inverter provides power to the inverter. When used externally, it can only be used as the power supply for voltage control signal, with current restricted below 20mA.
AI1	Input Signal	Voltage / Current analog input	When analog speed control is selected, the voltage or current signal is input through this terminal. The range of voltage input is 0~10V and the current input is 0~20mA, the input resistor is 500Ohm, and grounding: GND. If the input is 4~20mA, it can be realised by setting F406 to 2. The voltage or current signal can be chosen by coding switch. See Table 8-2 and Table 8-3 for details, the default setting of AI1 is 0~10V, and the default setting of AI2 is 0-20mA.
AI2			
GND		Self-contained Power supply Ground	Ground terminal of external control signal (voltage control signal or current source control signal) is also the ground of 10V power supply of this inverter.
24V	Power supply	Control power supply	Power: 24±1.5V, grounding is CM; current is restricted below 50mA for external use.
DI1	Digital input control terminal	Jogging terminal	When this terminal is valid, the inverter will have jogging running. The jogging function of this terminal is valid under both at stopped and running status.
DI2		External Emergency Stop	When this terminal is valid, "ESP" malfunction signal will be displayed.
DI3		"FWD" Terminal	When this terminal is valid, inverter will run forward.
DI4		"REV" Terminal	When this terminal is valid, inverter will run reverse.
DI5		Reset terminal	Make this terminal valid under fault status to reset the inverter.
CM	Common port	Grounding of control power supply	The grounding of 24V power supply and other control signals.
A+	RS485 communication terminals	Positive polarity of differential signal	Standard: TIA/EIA-485(RS-485) Communication protocol: Modbus Communication rate: 1200/2400/4800/9600/19200/38400/57600bps
B-		Negative polarity of Differential signal	

# 7-6 Installation & Connection

## 7.5 Wiring for Digital Input Terminals:

Generally, shielded cable is recommended and wiring distance should be as short as possible. When the analogue reference signal is used, it is necessary to take filter measures to prevent power supply interference.

Digital input terminals are only connected by source electrode (NPN mode) or by sink electrode (PNP mode). If NPN mode is adopted, please slide the toggle switch to the end of "NPN".

Wiring for control terminals as follows:

### 7.5.1 Wiring for positive source electrode (NPN mode).

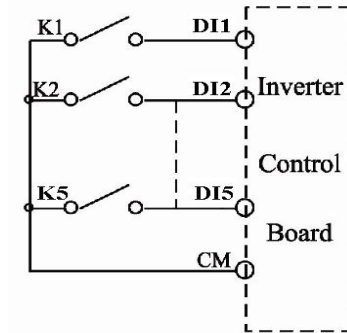

### 7.5.2 Wiring for active source electrode

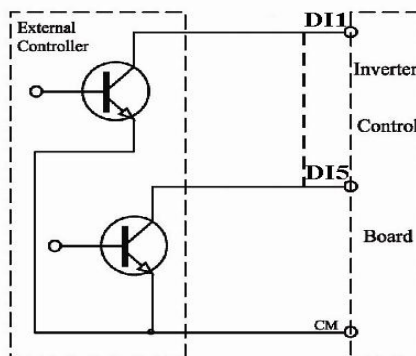

If digital input control terminals are connected by sink electrode, please slide the toggle switch to the end of "PNP". Wiring for control terminals as follows:

### 7.5.3 Wiring for positive Sink electrode (PNP mode)

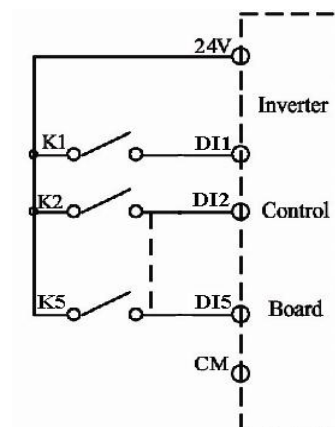

## 7.5.4 Wiring for active drain electrode (PNP mode)

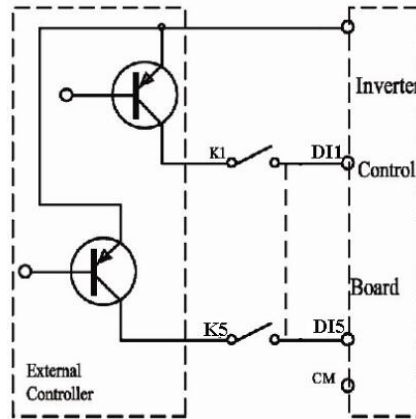

Wiring by source electrode is a mode most in use at present. Wiring for control terminal is connected by source electrode, user should choose wiring mode according to requirement.

Instructions of choosing NPN mode or PNP mode:

1. There is a toggle switch J7 near to control terminals. Please refer to Figure 7-2.
2. When turning J7 to "NPN", DI terminal is connected to CM.



Figure 7-2 Toggle Switch J7

When turning J7 to "PNP", DI terminal is connected to 24V.

J7 is on the back of control board for single-phase inverter 0.2-0.75KW.

# 7-8 Installation & Connection

## 7.6 Connection Overview

Refer to next figure for the overall connection sketch for AC10 series inverters. Various wiring modes are available for the terminals whereas not every terminal needs to be connected in each mode when applied.

Note:

Only connect power terminals L1/R and L2/S with power grid for single-phase inverters.

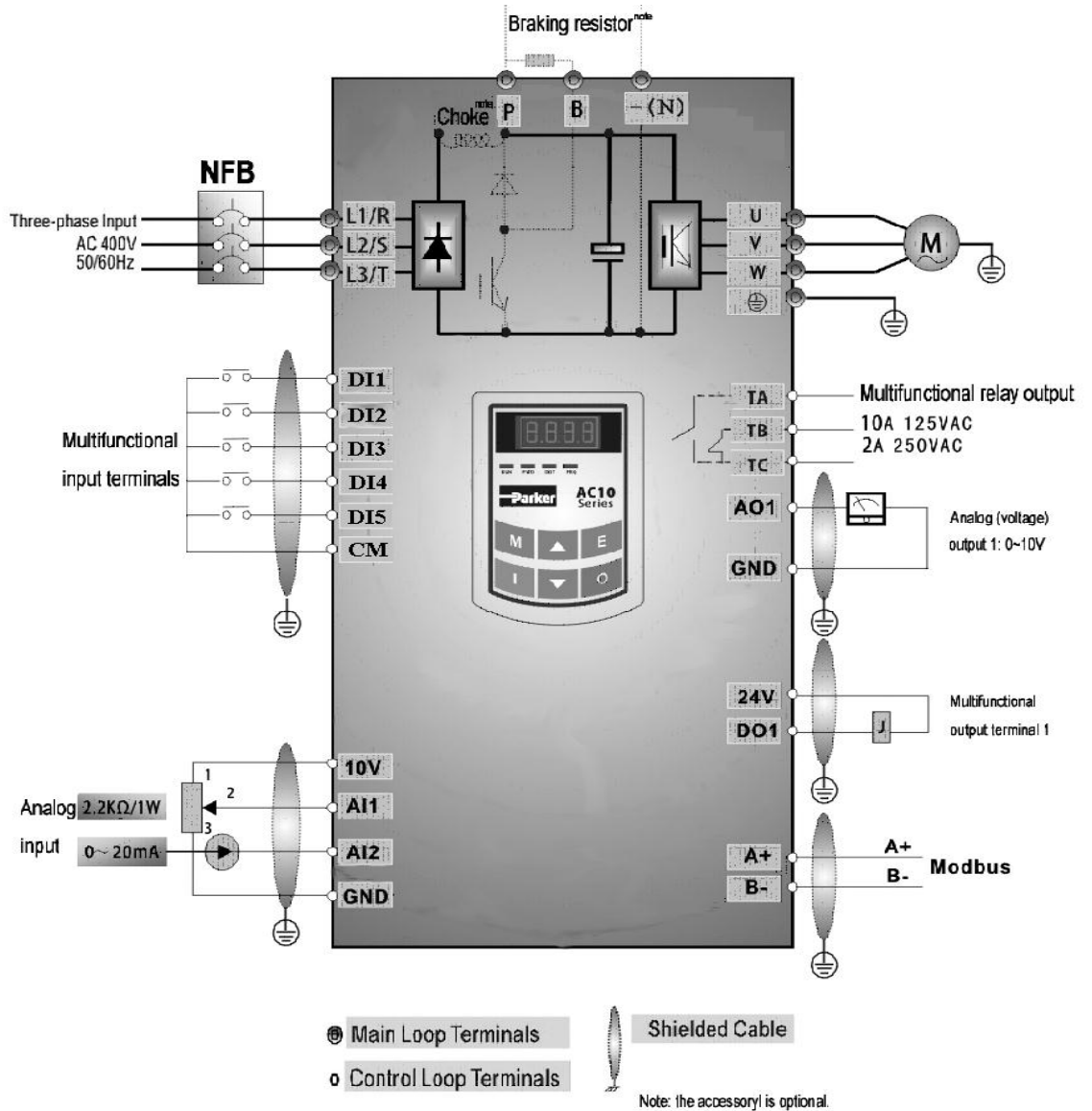

Basic Wiring Diagram for multi-stage speed control macro (NPN type)



## 7.7 Basic methods of suppressing the noise

The noise generated by the drive may disturb the equipment nearby. The degree of disturbance is dependent on the drive system, immunity of the equipment, wiring, installation clearance and earthing methods.

### 7.7.1 Noise propagation paths and suppressing methods

① Noise categories

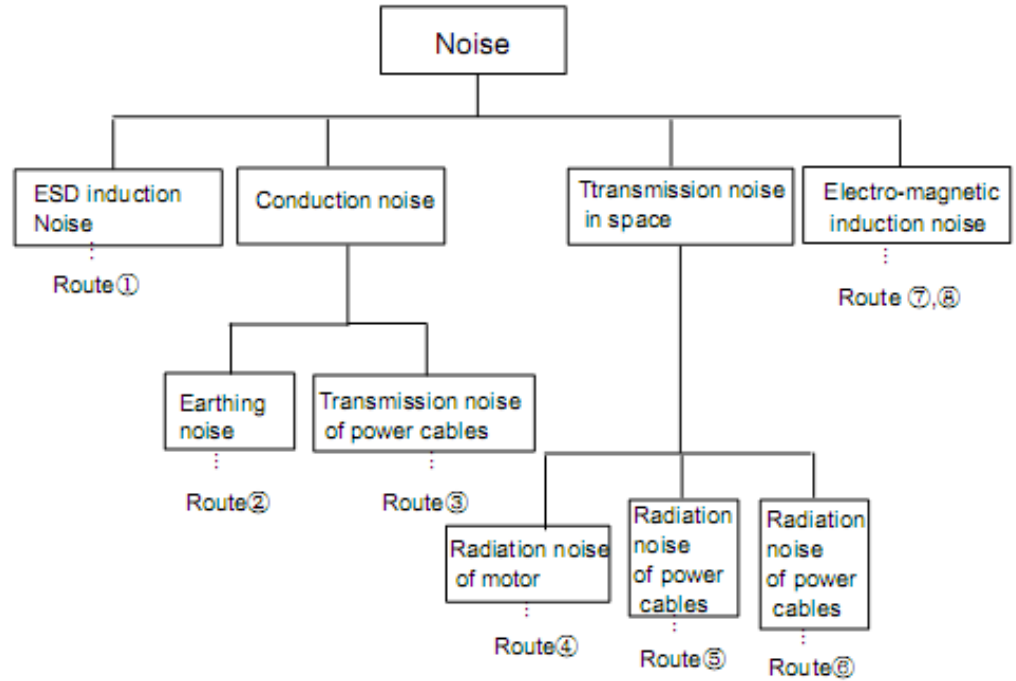

③ Noise propagation paths

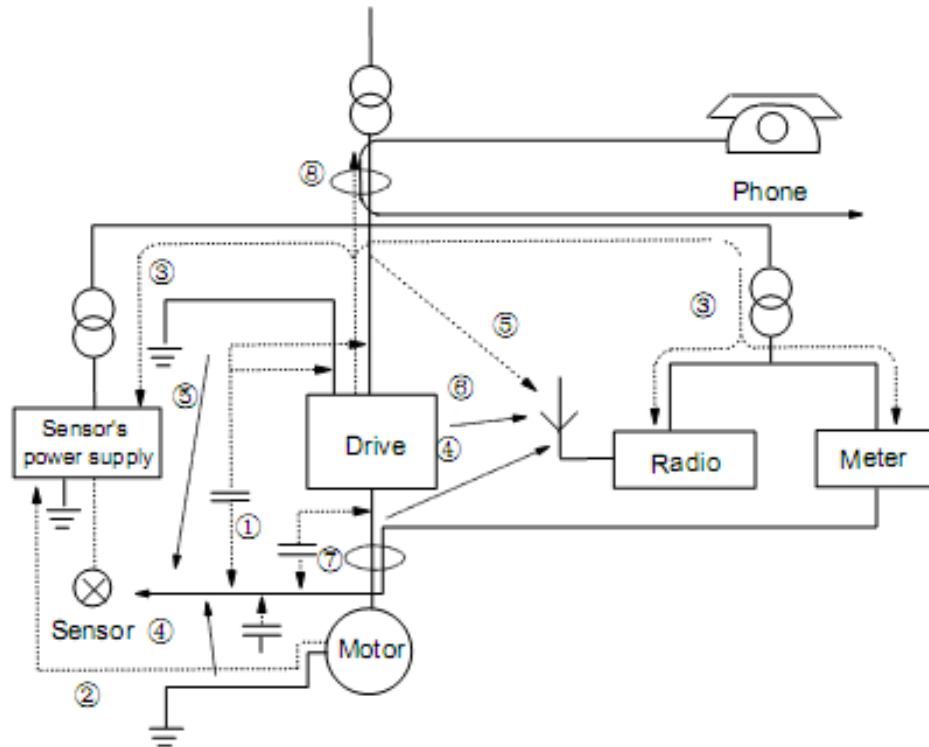

# 7-10 Installation & Connection

## 7.7.2 Basic methods of suppressing the noise

Noise emission paths	Actions to reduce the noise
2	When the external equipment forms a loop with the drive, the equipment may suffer nuisance tripping due to the drive's earth leakage current. The problem can be solved if the equipment is not grounded.
3	If the external equipment shares the same AC supply with the drive, the drive's noise may be transmitted along its input power supply cables, which may cause nuisance tripping to other external equipment. Take the following actions to solve this problem: Install noise filter at the input side of the drive, and use an isolation transformer or line filter to prevent the noise from disturbing the external equipment.
4,5,6	<p>If the signal cables of measuring meters, radio equipment and sensors are installed in a cabinet together with the drive, these equipment cables will be easily disturbed. Take the actions below to solve the problem:</p> <ol style="list-style-type: none"> <li>(1) The equipment and the signal cables should be as far away as possible from the drive. The signal cables should be shielded and the shielding layer should be grounded. The signal cables should be placed inside a metal tube and should be located as far away as possible from the input/output cables of the drive. If the signal cables must cross over the power cables, they should be placed at right angle to one another.</li> <li>(2) Install radio noise filter and linear noise filter (ferrite common-mode choke) at the input and output of the drive to suppress the emission noise of power lines.</li> <li>(3) Motor cables should be placed in a tube thicker than 2mm or buried in a cement conduit. Power cables should be placed inside a metal tube and be grounded by shielding layer</li> </ol>
1,7,8	Don't route the signal cables in parallel with the power cables or bundle these cables together because the induced electro-magnetic noise and induced ESD noise may disturb the signal cables. Other equipment should also be located as far away as possible from the drive. The signal cables should be placed inside a metal tube and should be placed as far away as possible from the input/output cables of the drive. The signal cables and power cables should be shielded cables. EMC interference will be further reduced if they could be placed inside metal tubes. The clearance between the metal tubes should be at least 20cm.

## 7.7.3 Field Wire Connections

Control cables, input power cables and motor cables should be installed separately and enough clearance should be left among the cables, especially when the cables are laid in parallel and the cable length is over 50 metres. If the signal cables must be laid with the power cables, they should be installed parallel to each other.

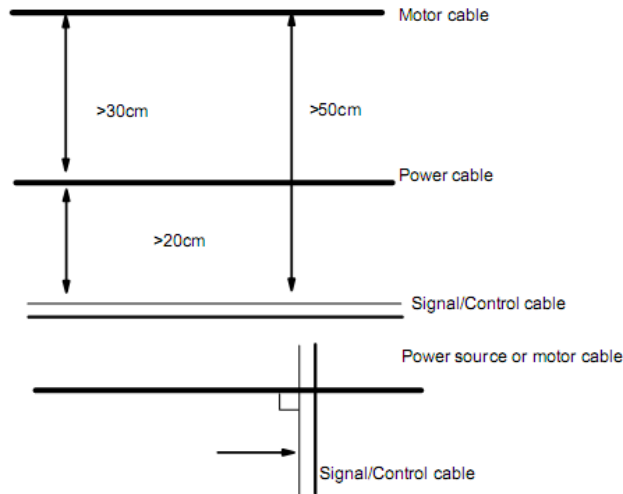

Generally, the control cables should be shielded cables and the shielding metal net must be connected to the metal enclosure of the drive by cable clamps.

## 7.7.4 Earthing

Independent earthing poles (best)

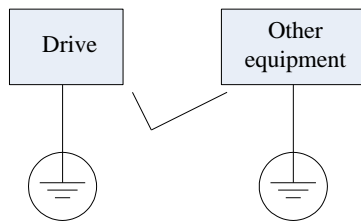

Shared earthing pole (good)

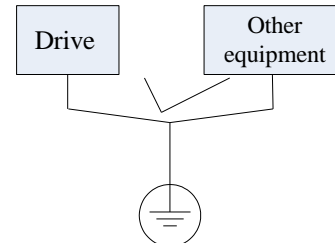

Shared earthing cable (not good)

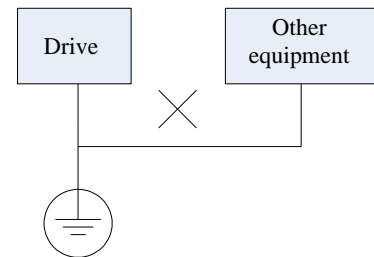
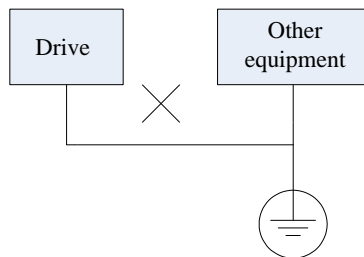

Note:

1. In order to reduce the earthing resistance, flat cable should be used because the high frequency impedance of flat cable is smaller than that of round cable with the same CSA.
2. If the earthing poles of different equipment in one system are connected together, then the leakage current will be a noise source that may disturb the whole system. Therefore, the drive's earthing pole should be separated with the earthing pole of other equipment such as audio equipment, sensors and PC, etc.
3. Earthing cables should be as far away from the I/O cables of the equipment that is sensitive to noise, and also should be as short as possible.

## 7-12 Installation & Connection

### 7.7.5 Leakage Current

Leakage current may flow through the drive's input and output capacitors and the motor. The leakage current value is dependent on the distributed capacitance and carrier wave frequency. The leakage current includes ground leakage current and the leakage current between lines.

#### Ground Leakage Current

The ground leakage current can not only flow into the drive system, but also other equipment via earthing cables. It may cause the leakage current circuit breaker and relays to falsely trip. The higher the drive's carrier wave frequency, the bigger the leakage current, also, the longer the motor cable, the greater the leakage current.

#### Suppressing Methods:

- Reduce the carrier wave frequency, but the motor noise may be louder;
- Motor cables should be as short as possible;
- The drive and other equipment should use leakage current circuit breaker designed for protecting the product against high-order harmonics/surge leakage current.

#### Leakage Current Between Lines

The line leakage current flowing through the distribution capacitors of the drive outside may cause the thermal relay to be falsely activated, especially for the drive whose power is lower than 7.5kW. When the cable is longer than 50m, the ratio of leakage current to motor rated current may be increased and can cause the wrong action of external thermal relay very easily.

#### Suppressing Methods:

- Reduce the carrier wave frequency, but the motor noise may become louder;
- Install reactor at the output side of the drive.

In order to protect the motor reliably, it is recommended to use a temperature sensor to detect the motor's temperature, and use the drive's over-load protection device (electronic thermal relay) instead of an external thermal relay.

### 7.7.6 Electrical Installation of the Drive

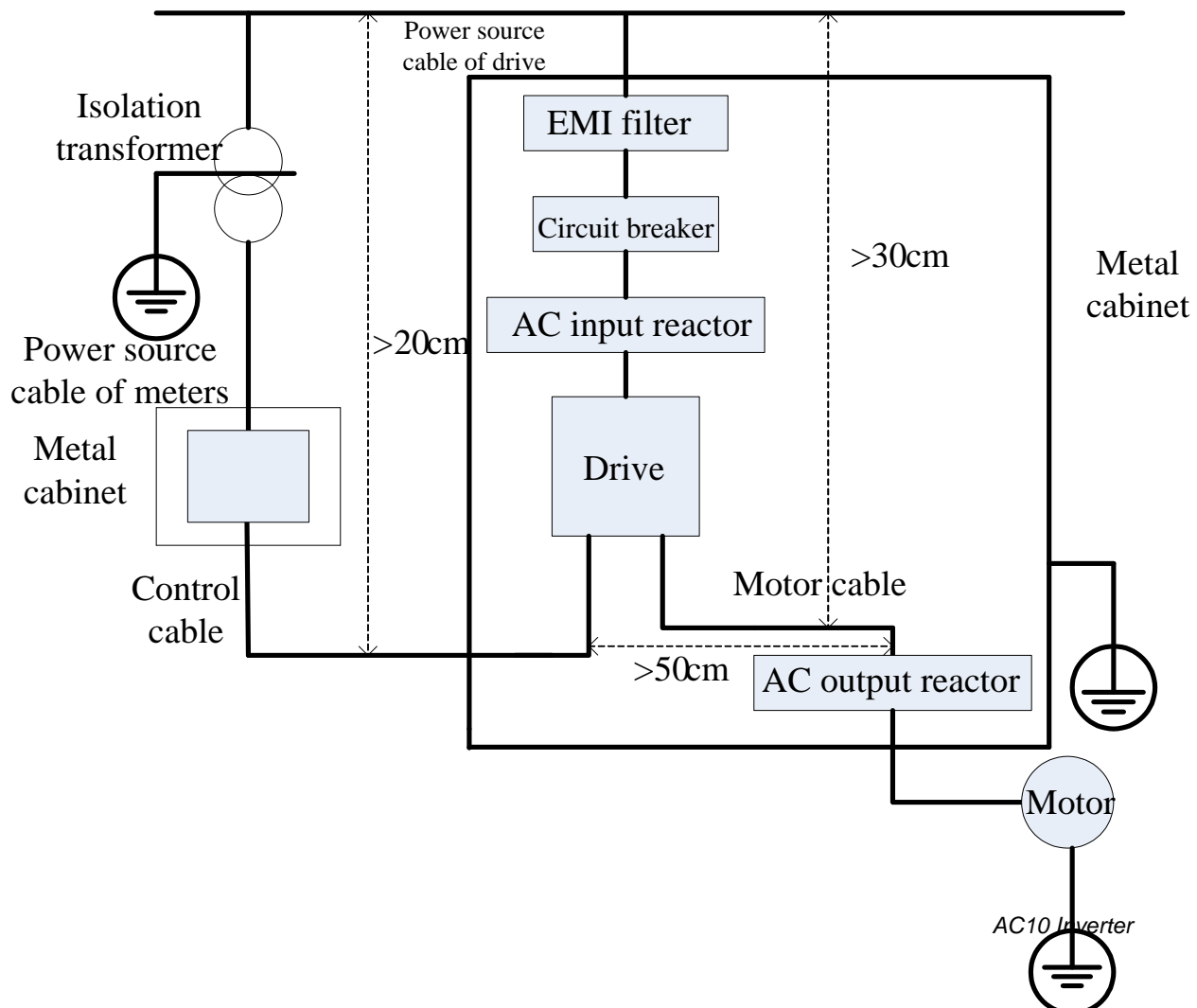

Note:

- Motor cable should be earthed at the drive side, if possible, the motor and drive should be earthed separately;
- Motor cable and control cable should be shielded. The shield must be earthed and avoid entangling at cable end to improve high frequency noise immunity.
- Assure good conductivity among plates, screw and metal case of the drive; use tooth-shape/spring washer and conductive installation plate;

### **7.7.7 Application of Power Line Filter**

Power source filter should be used in the equipment that may generate strong EMI or the equipment that is sensitive to the external EMI. The power source filter should be a two-way low pass filter through which only 50Hz current can flow and high frequency current should be rejected.

#### Function of Power Line Filter

The power line filter ensures the equipment can satisfy the conducting emission and conducting sensitivity in EMC standard. It can also suppress the radiation of the equipment.

Common mistakes in using power cable filter:

#### 1. Too long power cable

The filter inside the cabinet should be located near to the input power source. The length of the power cables should be as short as possible.

#### 2. The input and output cables of the AC supply filter are too close

The distance between input and output cables of the filter should be as far apart as possible, otherwise the high frequency noise may be coupled between the cables and bypass the filter. This will make the filter ineffective.

#### 3. Bad earthing of filter

The filter's enclosure must be earthed properly to the metal case of the drive. In order to be earthed well, make use of a special earthing terminal on the filter's enclosure. If you use one cable to connect the filter to the case, the earthing is useless for high frequency interference. When the frequency is high, so is the impedance of cable, hence there is little bypass effect. The filter should be mounted on the enclosure of equipment. Ensure to clear away the insulation paint between the filter case and the enclosure for good earthing contact.



# 8-1 Operation and Simple Running

## Chapter 8 Operation and Simple Running

This chapter defines and explains the terms and names describing the control, running and status of the inverter. Please read it carefully as it will ensure correct operation.

### 8.1 Basic Conception

#### 8.1.1 Control Mode

AC10 inverter has the following control modes: sensorless vector control (F106=0), VVVF control (F106=2) and vector control 1 (F106=3).

#### 8.1.2 Mode of Torque Compensation

Under VVVF control mode, AC10 inverter has four kinds of torque compensation modes:

Linear compensation (F137=0);

Square compensation (F137=1);

User-defined multipoint compensation (F137=2);

Auto torque compensation (F137=3)

#### 8.1.3 Mode of frequency setting

Please refer to F203~F207 for the method for setting the running frequency of the AC10 inverter.

#### 8.1.4 Mode of controlling for running command

The channel for inverter to receive control commands (including start, stop and jogging, etc) contains 5 modes:

0. Keypad control;

1. Terminal control;

2. Keypad + Terminal control

3. Modbus control;

4. Keypad + Terminal +Modbus

The modes of control command can be selected through the function codes F200 and F201.

#### 8.1.5 Operating status of inverter

When the inverter is powered on, it will have one of four types of operating status:

Stopped status

Programming status

Running status

Fault alarm status.

They are described in the following:

##### Stopped status

If the inverter is re-energised (if “auto-startup after being powered on” is not set) or decelerate the inverter to stop, the inverter is at the stopped status until receiving control command. At this point, the running status indicator on the keypad goes off and the display shows the display status before power down.

##### Programming status

Through keypad panel, the inverter can be switched to the status that can read or change the function code parameters. Such a status is the programming status.

There are numbers of function parameters in the inverter. By changing these parameters, the user can realize different control modes.

##### Running status

The inverter at the stopped status or fault-free status will enter running status after having received a start command.

The running indicator on keypad panel lights up under normal running status.

## **Fault alarm status**

The status under which the inverter has a fault and the fault code is displayed.

Fault codes mainly include: OC, OE, OL1, OL2, OH, LU, PF1 and PF0 representing “over current”, “over voltage”, “inverter overload”, “motor overload”, “overheat”, “input under-voltage”, “input phase loss”, and “output phase loss” respectively.

For troubleshooting, please refer to Chapter 10 “Troubleshooting”.

## **8.2 Keypad Panel and Operation Method**

Keypad panel (keypad) is fitted as a standard part for configuration of the AC10 inverter. Using the keypad panel, the user may carry out parameter setting, status monitoring and operation control over the inverter. Both keypad panel and display screen are arranged on the keypad controller, which mainly consists of three sections:

data display section,

status indicating section

and keypad operating section

It is necessary to know the functions and how to use the keypad panel. Please read this manual carefully before operation.

### **8.2.1 Method of operating the keypad panel**

### **8.2.2 Operation Process of Setting the Parameters using the Keypad Panel**

A three-level menu structure is adopted for setting the parameters using the keypad panel, which enables convenient and quick searching and changing of function code parameters.

Three-level menu:

Function code group (first-level menu)

Function code (second-level menu)

Set value of each function code (third-level menu).

### **8.2.3 Setting the Parameters**

Setting the parameters correctly is a precondition to give full inverter performance. The following is the introduction on how to set the parameters using the keypad panel.

Operating procedures:

- i. Press the “M” key, to enter programming menu.
- ii. Press the key “O”, the DGT lamp goes out. Press ▲ and ▼, the function code will change within the function code group. The first number behind F displayed on the panel shows the current function group, in other words, if it displays F1xxat this moment then basic parameters F100 – F160 is selected.
- iii. Press the key “O” again, the DGT lamp lights up. Press ▲ and ▼ to scroll up and down the function code within the selected function group; press the “E” key to display 50.00; while press ▲ and ▼ to change to the need frequency.
- iv. Press the “E” key to complete the change.

### **8.2.4 Switching and displaying of status parameters**

Under stopped status or running status, the LED indicators of inverter can display status parameters of the inverter. Actual parameters displayed can be selected and set through function codes F131 and F132. Through the “M” key, it can switch over repeatedly and display the parameters of stopped status or running status. The followings are the description of operation method of displaying the parameters under stopped status and running status.



## 8-3 Operation and Simple Running

### 8.2.5 Switching of the parameters displayed under stopped status

Under stopped status, inverter has five parameters of stopped status, which can be switched over repeatedly and displayed with the keys "M" and "O". These parameters are displaying: keypad jogging, target rotary speed, PN voltage, PID feedback value, and temperature. Please refer to the description of function code F132.

### 8.2.6 Switching of the parameters displayed under running status

Under running status, eight parameters of running status can be switched over repeatedly and displayed with the keys "M". These parameters are displayed: output rotary speed, output current, output voltage, PN voltage, PID feedback value, temperature, count value and linear speed. Please refer to the description of function code F131.

### 8.2.7 Operation process of measuring motor parameters

The user shall input the parameters accurately as indicated on the nameplate of the motor prior to selecting operation mode of vector control and auto torque compensation (F137=3) of VVVF control mode. Inverter will match standard motor stator resistance parameters according to the parameters indicated on the nameplate. To achieve better control performance, the user may start the inverter to measure the motor stator resistance parameters, so as to obtain accurate parameters of the motor controlled.

The motor parameters can be tuned through function code F800.

For example: If the parameters indicated on the nameplate of the motor controlled are as follows: numbers of motor poles are 4; rated power is 7.5kW; rated voltage is 400V; rated current is 15.4A; rated frequency is 50.00HZ; and rated rotary speed is 1440rpm, operation process of measuring the parameters shall be done as described in the following:

In accordance with the above motor parameters, set the values of F801 to F805 correctly: set the value of F801 = 7.5, F802 = 400, F803 = 15.4, F804 = 4 and F805 = 1440 respectively.

1. In order to ensure dynamic control performance of the inverter, set F800=1, i.e. select rotating tuning. Make sure that the motor is disconnected from the load. Press the "I" key on the keypad, and the inverter will display "TEST", and it will tune the motor's parameters of two stages. After that, the motor will accelerate according to the acceleration time set at F114 and maintain for a certain period. The speed of motor will then decelerate to 0 according to the time set at F115. After auto-checking is completed, relevant parameters of the motor will be stored in function codes F806~F809, and F800 will turn to 0 automatically.

2. If it is impossible to disconnect the motor from the load, select F800=2, i.e. stationary tuning. Press the "I" key, the inverter will display "TEST", and it will tune the motor's parameters of two stages. The motor's stator resistance, rotor resistance and leakage inductance will be stored in F806-F808 automatically, and F800 will turn to 0 automatically. The user may also calculate and input the motor's mutual inductance value manually according to actual conditions of the motor.

## 8.2.8 Operation process of simple running

Table 8-1 Brief Introduction to Inverter Operation Process

Process	Operation	Reference
Installation and operation environment	Install the inverter at a location meeting the technical specifications and requirements of the product. Mainly take into consideration the environment conditions (temperature, humidity, etc) and heat radiation of the inverter, to check whether they can satisfy the requirements.	See Chapters 1, 2, 3.
Wiring of the inverter	Wiring of input and output terminals of the main circuit; wiring of grounding; wiring of switching value control terminal, analog terminal and communication interface, etc.	See Chapters 7 & 8.
Checking before getting energised	Make sure that the voltage of input power supply is correct; the input power supply loop is connected with a breaker; the inverter has been grounded correctly and reliably; the power cable is connected to the power supply input terminals of inverter correctly (R/L1, S/L2 terminals for single-phase power grid, and R/L1, S/L2, and T/L3 for three-phase power grid); the output terminals U, V, and W of the inverter are connected to the motor correctly; the wiring of control terminals is correct; all the external switches are preset correctly; and the motor is under no load (the mechanical load is disconnected from the motor).	See Chapter 7
Checking immediately after energised	Check if there is any abnormal sound, smell with the inverter. Make sure that the display of keypad panel is normal, without any fault alarm message. In case of any abnormality, switch off the power supply immediately.	See Chapter 8
Inputting the parameters indicated on the motor's nameplate correctly, and measuring the motor's parameters.	Make sure to input the parameters indicated on the motor nameplate correctly, and study the parameters of the motor. The users shall check carefully, otherwise, serious problems may arise during running. Before initial running with vector control mode, carry out tuning of motor parameters, to obtain accurate electric parameters of the motor controlled. Before carrying out tuning of the parameters, make sure to disconnect the motor from mechanical load, to make the motor under entirely no load status. It is prohibited to measure the parameters when the motor is at a running status.	See description of parameter group F800~F830
Setting running control parameters	Set the parameters of the inverter and the motor correctly, which mainly include target frequency, upper and lower frequency limits, acceleration/deceleration time, and direction control command, etc. The user can select corresponding running control mode according to actual applications.	See description of parameter group.
Checking under no load	With the motor under no load, start the inverter with the keypad or control terminal. Check and confirm running status of the drive system. Motor's status: stable running, normal running, correct rotary direction, normal acceleration/deceleration process, free from abnormal vibration and abnormal noise. Inverter' status: normal display of the data on keypad panel, normal running of the fan, normal acting sequence of the relay, free from the abnormalities like vibration or noise. In case of any abnormality, stop and check the inverter immediately.	See Chapter 8.
Checking under with Load	After successful test run under no load, connect the load of drive system properly. Start the inverter with the keypad or control terminal, and increase the load gradually. When the load is increased to 50% and 100%, keep the inverter run for a period respectively, to check if the system is running normally. Carry out overall inspection over the inverter during running, to check if there is any abnormality. In case of any abnormality, stop and check the inverter immediately.	
Checking during running	Check if the motor is running stable, if the rotary direction of the motor is correct, if there is any abnormal vibration or noise when the motor is running, if the acceleration/deceleration process of the motor is stable, if the output status of the inverter and the display of keypad panel is correct, if the blower fan is run normally, and if there is any abnormal vibration or noise. In case of any abnormality, stop the inverter immediately, and check it after switching off the power supply.	

# 8-5 Operation and Simple Running

## 8.3 Illustration of Basic Operation

Illustration of inverter basic operation: we hereafter show various basic control operation processes by taking a 7.5kW inverter that drives a 7.5kW three-phase asynchronous AC motor as an example.

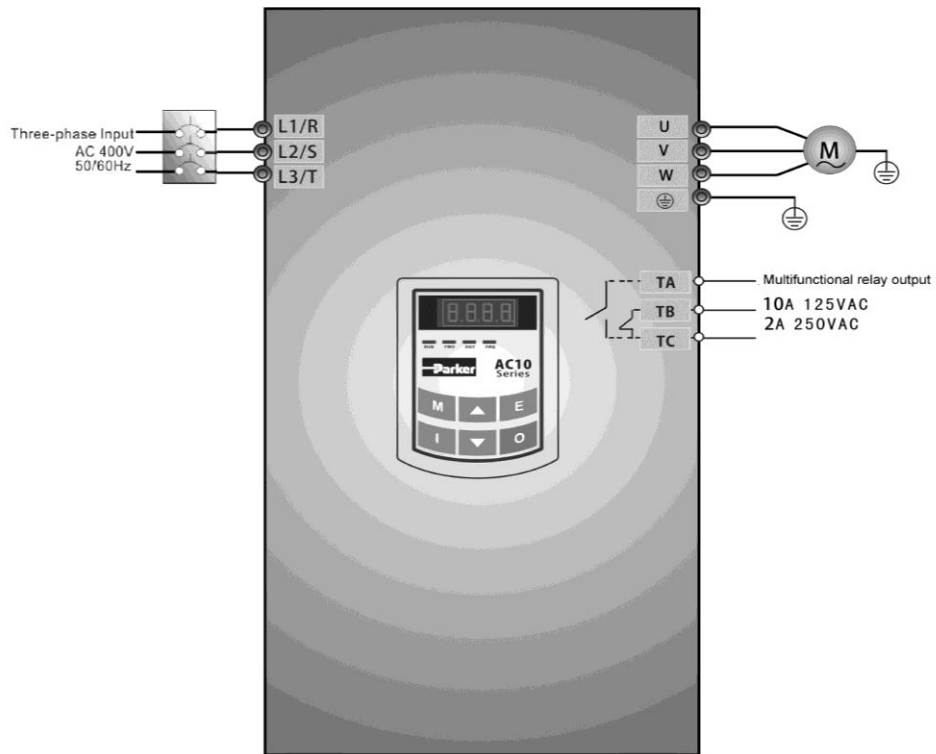

Figure 8-1 Wiring Diagram 1

The parameters indicated on the nameplate of the motor are as follows: 4 poles; rated power, 7.5kW; rated voltage, 400V; rated current, 15.4A; rated frequency 50.00HZ; and rated rotary speed, 1440rpm.

### 8.3.1 Frequency setting, start, forward running and stop using the keypad panel

- Connect the wires in accordance with Table 8-1. After having checked the wiring successfully, switch on the power to the inverter.
- Press the “M” key, to enter the programming menu
- Enter the parameters of the motor

Function	Values
F800	1(2)
F801	7.5
F802	400
F803	15.4
F805	1440

Press the “I” key, to autotune the parameters of the motor. After completion of the tuning, the motor will stop running, and relevant parameters will be stored in F806~F809. For the details of tuning of motor parameters, please refer to

## Operation and Simple Running 8-6

“Operation process of measuring the motor parameters” in this manual. (Note: F800=1 is rotating tuning, F800=2 is stationary tuning. In the mode of rotating tuning, make sure to disconnect the motor from the load).

- iv. Set functional parameters of the inverter:

Function code	Values
F111	50.00
F200	0
F201	0
F202	0
F203	0

- v. Press the “I” key, to start the inverter;
- vi. During running, current frequency of the inverter can be changed by pressing ▲ or ▼;
- vii. Press the “O” key once, the motor will decelerate until it stops running;
- viii. Switch off the air switch, and power off the inverter.

### 8.3.2 Setting the frequency using the keypad panel, and starting, forward and reverse running, and stopping inverter through control terminals

- i. Connect the wires in accordance with **Figure 8-2**. After having checked the wiring successfully, switch on the air switch, and power on the inverter;

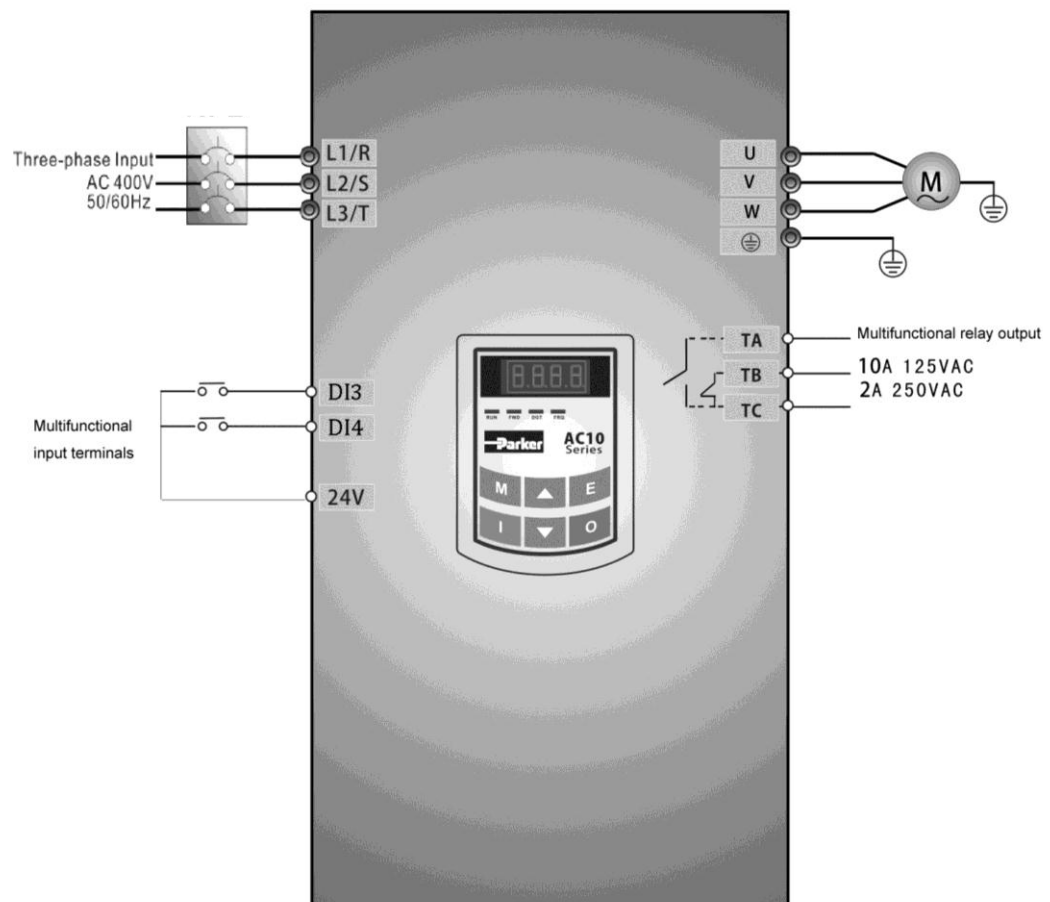

Figure 8-2 Wiring Diagram 2

## 8-7 Operation and Simple Running

- ii. Press the “M” key, to enter the programming menu.
- iii. Study the parameters of the motor: the operation process is the same as that of example 1. (Refer to 8.3.1 for tuning of the motor).
- iv. Set functional parameters of the inverter:

Function code	Values
F111	50.00
F203	0
F208	1

- v. Close the switch DI3, the inverter starts forward running;
- vi. During running, current frequency of the inverter can be changed by pressing ▲ or ▼;
- vii. During running, switch off the switch DI3, then close the switch DI4, the running direction of the motor will be changed (Note: The user should set the dead time of forward and reverse running F120 on the basis of the load. If it was too short, OC protection of the inverter may occur.)
- viii. Switch off the switches DI3 and DI4, the motor will decelerate until it stops running;
- ix. Switch off the isolator, and power off the inverter.

### 8.3.3 Operation process of jogging operation using the keypad panel

- i. Connect the wires in accordance with Figure 8-1. After having checked the wiring successfully, switch on the isolator, and power on the inverter;
- ii. Press the “M” key, to enter the programming menu.
- iii. Study the parameters of the motor: the operation process is the same as that of example 1. (Refer to 8.3.1 for tuning of the motor).
- iv. Set functional parameters of the inverter:

Function code	Values
F124	5.00
F125	30
F126	30
F132	1
F202	0

- v. Press and hold the “I” key until the motor is accelerated to the jogging frequency, and maintain the status of jogging operation.
- vi. Release the “I” key. The motor will decelerate until jogging operation is stopped;
- vii. Switch off the isolator, and power off the inverter.

## 8.3.4 Setting the frequency with analog terminal and controlling the operation with control terminals

- i. Connect the wires in accordance with **Figure 8-3**. After having checked the wiring successfully, switch on the mains supply, and power on the inverter. Note: 2K~5K potentiometer may be used for setting external analog signals. For the cases with higher requirements for precision, a precise multturn potentiometer is recommended, and adopt shielded wire for the wire connection, with near end of the shielding layer grounded reliably.

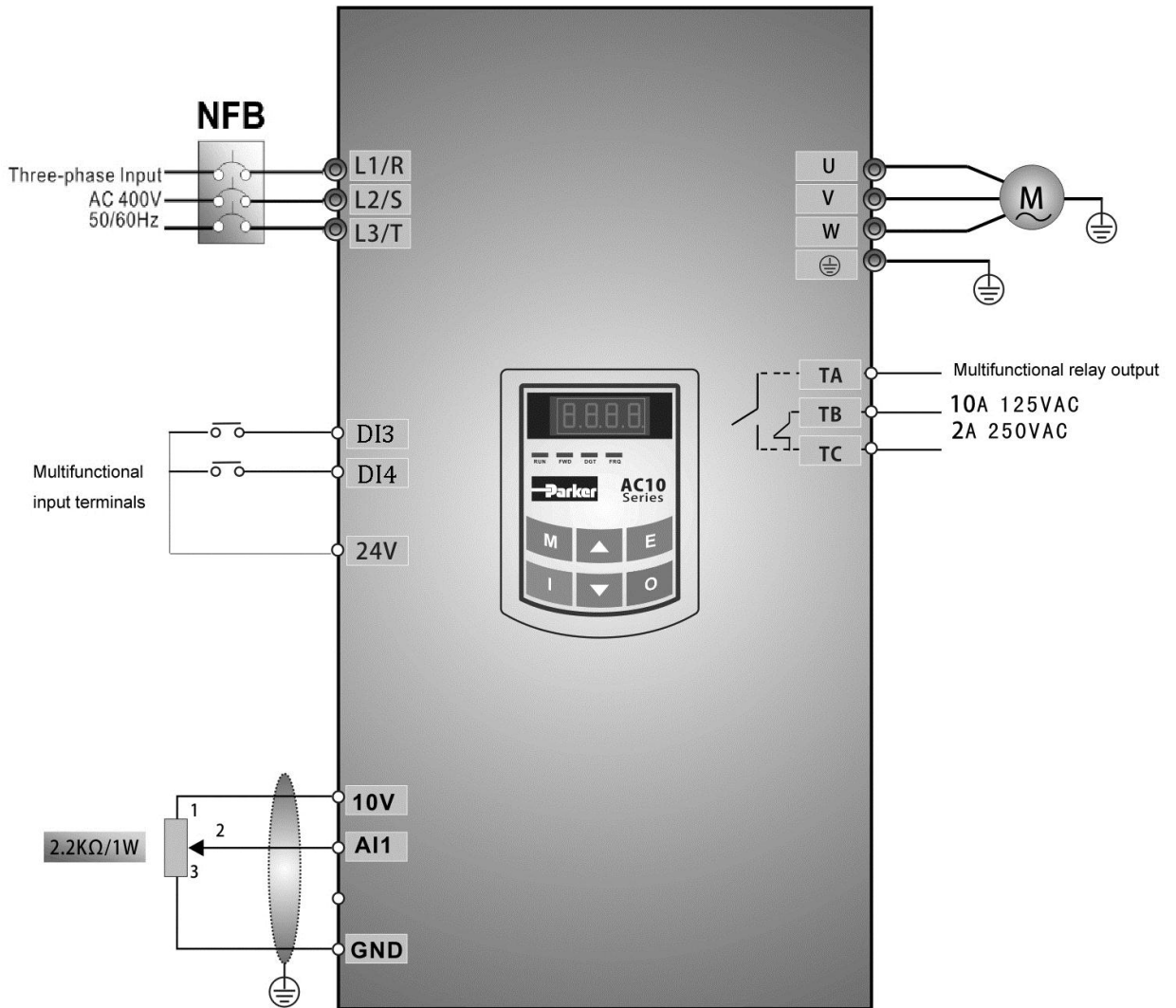

Figure 8-3 Wiring Diagram 3

- ii. Press the “M” key, to enter the programming menu.
- iii. Study the parameters of the motor: the operation process is the same as that of example 1. (Refer to 8.3.1 for tuning of the motor).
- iv. Set functional parameters of the inverter:

Function code	Values
F203	1
F208	1

## 8-9 Operation and Simple Running

- v. (5) There is a red two-digit coding switch SW1 near the control terminal block, as shown in Figure 4-4. The function of coding switch is to select the voltage signal (0~5V/0~10V) or current signal of analog input terminal AI2, current channel is default. In actual application, select the analog input channel through F203. Turn switches 1 to ON and 2 to ON as illustrated in the figure, and select 0~20mA current speed control. Other switches state and mode of control speed are shown in table **Table 8-2**.
- vi. (6) Close the switch DI3, the motor starts forward running;
- vii. (7) The potentiometer can be adjusted and set during running, and the current setting frequency of the inverter can be changed;
- viii. (8) During running process, switch off the switch DI3, then, close DI4, the running direction of the motor will be changed;
- ix. (9) Switch off the switches DI3 and DI4, the motor will decelerate until it stops running;
- x. (10) Switch off the air switch, and power off the inverter.
- xi. (11) Analog output terminal AO1 can output voltage and current signal, the selecting switch is J5, please refer to Figure 8-5 the output relation is shown in Table 8-3.

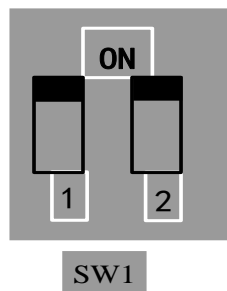

Figure 8-4

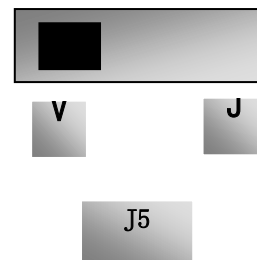

Figure 8-5

The Setting of Coding Switch and Parameters in the Mode of Analog Speed Control

Table 8-2

F203=2, channel AI2 is selected			F203=1, channel AI1 is selected
SW1 coding switch			0~10V voltage
Coding Switch 1	Coding Switch 2	Mode of Speed Control	
OFF	OFF	0~5V voltage	
OFF	ON	0~10V voltage	
ON	ON	0~20mA current	

Table 8-3 The relationship between AO1 and J5 and F423

AO1 output		Setting of F423		
		0	1	2
J5	V	0~5V	0~10V	Reserved
	I	Reserved	0~20mA	4~20mA





# Chapter 9 Function Parameters

## 9.1 Basic Parameters

F100	User's Password	Setting range: 0~9999	Mfr's value: 0
------	-----------------	--------------------------	----------------

When F107=1 with valid password, the user must enter correct user's password after power on or fault reset if you intend to change parameters. Otherwise, parameter setting will not be possible, and a prompt "Err1" will be displayed.

Relating function code: F107 Password valid or not F108 Setting user's password

F102	Inverter's Rated Current (A)		Mfr's value: Subject to inverter model
F103	Inverter Power (kW)		Mfr's value: Subject to inverter model

Rated current and rated power can only be checked but cannot be modified.

F105	Software Edition No.		Mfr's value: Subject to inverter model
------	----------------------	--	----------------------------------------

Software Edition No. can only be checked but cannot be modified.

F106	Control mode	Setting range: 0:Sensorless vector control (SVC); 1: Reserved; 2: VVVF; 3: Vector control 1 6 (Synchronous motor control mode)	Mfr's value: 2
------	--------------	-----------------------------------------------------------------------------------------------------------------------------------------------	----------------

**0: Sensorless vector control** is suitable for the application of high-performance requirement. One inverter can only drive one motor.

**2: VVVF** control is suitable for common requirement of control precision or one inverter drives several motors.

**3: Vector control 1** is auto torque promotion, which has the same function of F137=3. While studying motor parameters, motor does not need to be disconnected with load. One inverter can only drive one motor.

Note:

- It is necessary to study the parameters of motor before inverter runs in the sensorless vector control.
- Under sensorless vector control, one inverter can only drive one motor and the power of motor should be similar to the power of inverter. Otherwise, control performance will be decreased or the system cannot work properly.
- The operator may input motor parameters manually according to the motor parameters given by motor manufactures.
- Usually, the motor will work normally by inverter's default parameters, but the inverter's best control performance will not be acquired. Therefore, in order to get the best control performance, please study the parameters of motor before inverter runs in the sensorless vector control.

## 9-2 Function Parameters

### 6 (Synchronous motor control mode)

- When F106=6, default values of frequency source can not be adjusted automatically.
- When F106=6, independent DC brake function is adopted. And F602 and F603 change to percentage of the PMSM rated current;(Default value = 10%)
- F800: auto tuning of motor's parameter, F800=0, No parameter measurement, input the parameters of PMSM from F870 to F873 by hand. F800=1/2, running parameter measurement / static parameter measurement.
- The running command is given by keypad panel or terminals, then the keypad panel will display "TEST" till parameter measurement is over. The parameters of PMSM will be stored in function codes from F870 to F873 automatically.
- F800=1, running parameter measurement. In order to ensure dynamic control performance of the inverter, select "running motor parameter measurement" after ensuring that the motor is disconnected from the load. At the last stage of parameter measurement, motor will run at the first or second accel/decel time.
- F800=2, Static parameter measurement. It is suitable for the cases where it is impossible to disconnect the motor from the load. In this process, the value of F870 is a theoretical value. We suggest you that you can get the exact back electromotive force value from the manufacture of the motor.
- F804 The number of motor poles is automatically generated according to the motor rated speed and rated frequency, it can not be set.
- Note: after setting the motor parameters, please check the motor number of poles carefully. If it is different with actual value, when input the value of F810 according to motor nameplate, add one in the first digit after the decimal and change the second digit after the decimal to 0.
- The function codes of F813、F814、F815、F816、F817、F818、F819、F820、F821 are used by synchronous motor and asynchronous motor.
- F870(back electromotive force of PMSM, unit = 0.1mV/1rpm, it is back electromotive force value between lines); $\in [0.1, 999.9]$  mV/rpm, it is forbidden to revert to Mfr's value by F160.
- F871(PMSM D-axis inductance, unit = 0.01 mH); $\in [0.01, 655.35]$ mH, it is forbidden to revert to Mfr's value by F160.
- F872(PMSM Q-axis inductance, unit = 0.01 mH); $\in [0.01, 655.35]$ mH, it is forbidden to revert to Mfr's value by F160.
- F873(PMSM Stator resistance, unit = m-ohm, 0.001 ohm); $\in [0.001, 65.535]$ ohm, it is forbidden to revert to Mfr's value by F160.
- F876(PM Injection current compensation without load, unit = 0.1%); $\in [0.0, 100.0]$  the default value is 20.0%, it can be reverted to Mfr's value by F160;
- F877(PM Injection current compensation without load, unit = 0.1%); $\in [0.0, 50.0]$  the default value is 0.0%, it can be reverted to Mfr's value by F160.
- F878(PM Cut-off point of injection current compensation without load, unit = 0.1%); $\in [0.0, 50.0]$  the default value is 10.0%, it can be reverted to Mfr's value by F160;
- Caution: take an note of the value of F876, F877 and F878:
- When F876=20%, if F877=10%, F878=0%, then the value of injection current without load is always 20(F876)

Example: F876=20% (of rated current), F877=10% (of reted current), F878=10% (of rated frequency) - Rated frequency=50Hz, rated current=10A:

The drive starts at 0 Hz with a no-load current of 3A (20%+10% of 10A), the no-load current decreases linearly to 2A (20%) until the drive reaches the cut-off point of 5 Hz (10%of 50Hz), remaining constant for all frequency above 5 Hz.

- F880(PM PCE detection time, unit = 0.1s); $\in [0, 10.0]$ S the default value is 0.2S, it can be reverted to Mfr's value by F160.

F107 Password Valid or Not	Setting range: 0: invalid; 1: valid	Mfr's value: 0
F108 Setting User's Password	Setting range: 0~9999	Mfr's value: 8

When F107 is set to 0, the function codes can be changed without inputting the password.

When F107 is set to 1, the function codes can be changed only after inputting the user's password by F100.

The user can change "User's Password". The operation process is the same as those of changing other parameters.

Input the value of F108 into F100, and the user's password can be unlocked.

Note: When password protection is valid, and if the user's password is not entered, F108 will display 0.

F109 Starting Frequency (Hz)	Setting range: 0.00~10.00	Mfr's value: 0.00
F110 Holding Time of Starting Frequency (S)	Setting range: 0.0~999.9	Mfr's value: 0.0

The inverter begins to run from the starting frequency. If the target frequency is lower than starting frequency, F109 is invalid.

The inverter begins to run from the starting frequency. After it keeps running at the starting frequency for the time as set in F110, it will accelerate to target frequency. The holding time is not included in acceleration/deceleration time.

Starting frequency is not limited by the Min frequency set by F112. If the starting frequency set by F109 is lower than Min frequency set by F112, inverter will start according to the setting parameters set by F109 and F110. After inverter starts and runs normally, the frequency will be limited by frequency set by F111 and F112.

Starting frequency should be lower than Max frequency set by F111.

Note: When Flycatching is adopted, F109 and F110 are invalid.

F111 Max Frequency (Hz)	Setting range: F113~650.0	Mfr's value: 50.00
F112 Min Frequency (Hz)	Setting range: 0.00~F113	Mfr's value: 0.50

Max frequency is set by F111.

Min frequency is set by F112.

The setting value of min frequency should be lower than target frequency set by F113.

The inverter begins to run from the starting frequency. During inverter running, if the given frequency is lower than min frequency, then inverter will run at min frequency until inverter stops or given frequency is higher than min frequency.

Max/Min frequency should be set according to the nameplate parameters and running situations of motor. The motor should not run at low frequency for a long time, or else motor will be damaged because of overheating.

F113 Target Frequency (Hz)	Setting range: F112~F111	Mfr's value: 50.00
----------------------------	-----------------------------	--------------------

It shows the preset frequency. Under keypad speed control or terminal speed control mode, the inverter will run to this frequency automatically after startup.

## 9-4 Function Parameters

F114	First Acceleration Time (S)	Setting range: 0.1~3000	Mfr's value: subject to inverter model
F115	First Deceleration Time (S)		
F116	Second Acceleration Time (S)		
F117	Second Deceleration Time (S)		

F119 is used to set the reference of setting accel/decel time.

The Acceleration/Deceleration time can be chosen by multifunction digital input terminals F316~F323 and connecting DI terminal with CM terminal. Please refer to the instructions of multi-functional input terminals.

Note: When Flycatching is working, acceleration/deceleration time, min frequency and target frequency are invalid. After Flycatching is finished, inverter will run to target frequency according to acceleration/deceleration time.

F118	Base Frequency (Hz)	Setting range: 15.00~650.0	Mfr's value: 50.00Hz
------	---------------------	-------------------------------	-------------------------

Base frequency is the final frequency of VVVF curve, and also is the least frequency according to the highest output voltage.

When running frequency is lower than this value, inverter has constant-torque output. When running frequency exceeds this value, inverter has constant-power output.

Note: During the process of Flycatching, base frequency is invalid. After Flycatching is finished, this function code is valid.

F119	The reference of setting accel/decel time	Setting range: 0: 0~50.00Hz 1: 0~F111	Mfr's value: 0
------	-------------------------------------------	---------------------------------------------	----------------

When F119=0, acceleration/ deceleration time means the time for inverter to accelerate/ decelerate from 0Hz (50Hz) to 50Hz (0Hz).

When F119=1, acceleration/ deceleration time means the time for inverter to accelerate/ decelerate from 0Hz (max frequency) to max frequency (0Hz).

F120	Forward / Reverse Switchover dead-Time (S)	Setting range: 0.0~3000	Mfr's value: 0.0
------	--------------------------------------------	----------------------------	------------------

Within "forward/ reverse switchover dead-time", this latency time will be cancelled and the inverter will switch to run in the other direction immediately upon receiving "stop" signal. This function is suitable for all the speed control modes except automatic cycle operation.

This function can ease the current impact in the process of direction switchover.

Note: During the process of Flycatching, F120 is invalid. After Flycatching is finished, this function code is valid.

F122	Reverse Running Forbidden	Setting range: 0: invalid; 1: valid	Mfr's value: 0
------	---------------------------	-------------------------------------------	----------------

When F122=1, inverter will only run forward no matter the state of terminals and the parameters set by F202.

Inverter will not run reverse and forward / reverse switchover is forbidden. If reverse signal is given, inverter will stop.

If reverse running locking is valid (F202=1), inverter has no output.

When F122=1, F613=1, F614≥2 and inverter gets forward running command and motor is rotating

## Function Parameters 9-5

in reverse, the inverter will run to 0.0Hz reverse, then run forward according to the setting value of parameters.

If reverse running locking is valid (F202=1), whatever Flycatching is valid or not, inverter has no output.

When F122=1, F613=1, F614≥2 and inverter gets forward running command and motor is sliding reverse, if inverter can detect the sliding direction and track to motor speed, then inverter will run to 0.0Hz reverse, then run forward according to the setting value of parameters.

F123 Minus frequency is valid in the mode of combined speed control.	0: Invalid; 1: valid	0
----------------------------------------------------------------------	-------------------------	---

In the mode of combined speed control, if running frequency is minus and F123=0, inverter will run at 0Hz; if F123=1, inverter will run reverse at this frequency. (This function is controlled by F122.)

F124 Jogging Frequency (Hz)	Setting range: F112~F111	Mfr's value: 5.00Hz
F125 Jogging Acceleration Time (S)	Setting range: 0.1~3000	Mfr's value: subject to inverter model
F126 Jogging Deceleration Time (S)		

There are two types of jogging: keypad jogging and terminal jogging. Keypad jogging is valid only under stopped status (F132 including of displaying items of keypad jogging should be set).

Terminal jogging is valid under both running status and stopped status. Carry out jogging operation through the keypad (under stopped status):

- Press the "M" key, it will display "HF-0";
- Press the "I" key, the inverter will run to "jogging frequency" (if pressing "M" key again, "keypad jogging" will be cancelled).

Jogging Acceleration Time: the time for inverter to accelerate from 0Hz to 50Hz.

Jogging Deceleration Time: the time for inverter to decelerate from 50Hz to 0Hz.

In case of terminal jogging, make "jogging" terminal (such as DI1) connected to CM, and inverter will run to jogging frequency. The rated function codes are from F316 to F323.

Note: When jogging function is valid, Flycatching function is invalid.

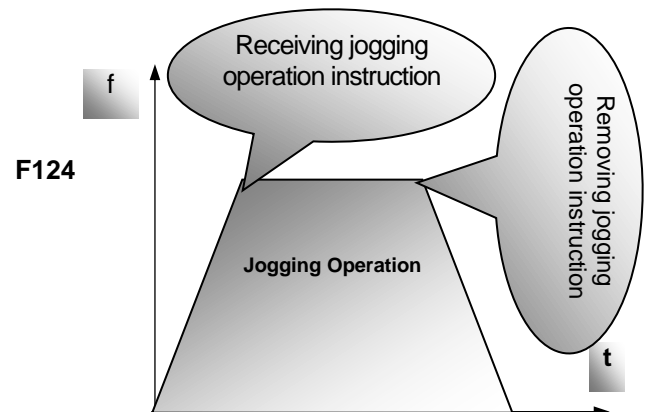

Figure 9-1 Jogging Operation

## 9-6 Function Parameters

F127/F129	Skip Frequency A,B (Hz)	Setting range: 0.00~650.0	Mfr's value:0.00Hz
F128/F130	Skip Width A,B (Hz)	Setting range: ±2.5	Mfr's value: 0.0

Systematic vibration may occur when the motor is running at a certain frequency. This parameter is set to skip this frequency.

The inverter will skip the point automatically when output frequency is equal to the set value of this parameter.

“Skip Width” is the span from the upper to the lower limits around Skip Frequency. For example, Skip Frequency=20Hz, Skip Width=±0.5Hz, inverter will skip automatically when output is between 19.5~20.5Hz.

Inverter will not skip this frequency span during acceleration/deceleration.

Note: During the process of Flycatching, skip frequency function is invalid. After Flycatching is finished, this function is valid.

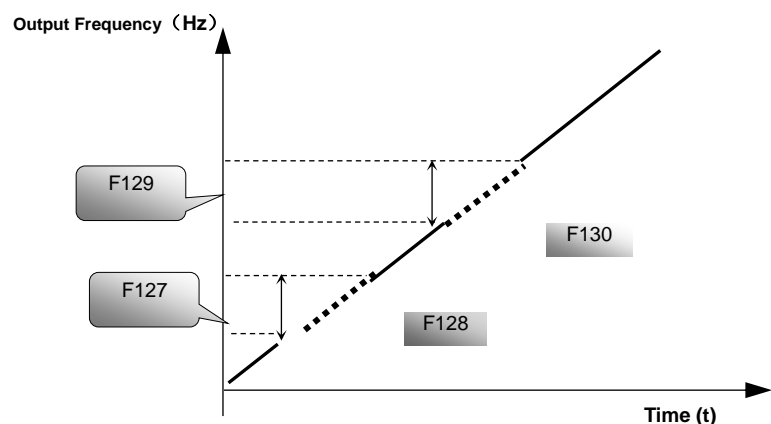

Figure 9-2 Skip Frequency

F131 Running Display Items	<ul style="list-style-type: none"> <li>0—Current output frequency/function-code</li> <li>1—Output rotary speed</li> <li>2—Output current</li> <li>4—Output voltage</li> <li>8—PN voltage</li> <li>16—PID feedback value</li> <li>32—Temperature</li> <li>64—Reserved</li> <li>128—Linear speed</li> <li>256—PID given value</li> <li>512—Reserved</li> <li>1024—Reserved</li> <li>2048—Output power</li> <li>4096— Output torque</li> </ul>	Mfr's value: 0+1+2+4+8=15
----------------------------	---------------------------------------------------------------------------------------------------------------------------------------------------------------------------------------------------------------------------------------------------------------------------------------------------------------------------------------------------------------------------------------------------------------------------------------------	------------------------------

Selection of one value from 1, 2, 4, 8, 16, 32, 64 and 128 shows that only one specific display item is selected. Should multiple display items be intended, add the values of the corresponding display items and take the total values as the set value of F131, e.g., just set F131 to be 19 (1+2+16) if you want to call “current output rotary speed”, “output current” and “PID feedback value”. The other display items will be covered.

As F131=8191, all display items are visible, of which, “frequency/function-code” will be visible whether or not it is selected.

Should you intend to check any display item, press the “M” key for switchover.

Refer to the following table for each specific value unit and its indication:

## Function Parameters 9-7

Whatever the value of F131 is set to, corresponding target frequency will flash under stopped status.

Target rotary speed is an integral number. If it exceeds 9999, add a decimal point to it.

Current display A \*.\* Bus voltage display U\*\*\* Output voltage display u\*\*\* Temperature H\*\*\*Linear speed L\*\*\*. If it exceeds 999, add a decimal point to it. If it exceeds 9999, add two decimal points to it, and the like.

PID given value o\*.\* PID feedback value b\*.\*

output power \*.\* output torque \*.\*

F132	Display items of stop	Setting range: 0: Frequency/function-code 1: Keypad jogging 2: Target rotary speed 4: PN voltage 8: PID feedback value 16: Temperature 32: Reserved 64: PID given value 128: Reserved 256: Reserved 512: Setting torque	Mfr's value: 0+2+4=6
F133	Drive ratio of driven system	Setting range: 0.10~200.0	Mfr's value:
F134	Transmission-wheel radius	0.001~1.000 (m)	Mfr's value: 0.001

Calculation of rotary speed and linear speed:

For example, If inverter's max frequency F111=50.00Hz, numbers of motor poles F804=4, drive ratio F133=1.00, transmission-shaft radius R=0.05m, then

Transmission shaft perimeter:  $2\pi R = 2 \times 3.14 \times 0.05 = 0.314$  (meter)

Transmission shaft rotary speed:  $60 \times \text{operation frequency} / (\text{numbers of poles pairs} \times \text{drive ratio}) = 60 \times 50 / (2 \times 1.00) = 1500$ rpm

Endmost linear speed: rotary speed  $\times$  perimeter =  $1500 \times 0.314 = 471$ (meters/second)

F136	Slip compensation	Setting range: 0~10	Mfr's value: 0
------	-------------------	---------------------	----------------

Under VVVF controlling, rotary speed of motor rotor will decrease as load increases. Be assured that rotor rotate speed is near to synchronization rotary speed while motor with rated load, slip compensation should be adopted according to the setting value of frequency compensation.

Note: During the process of Flycatching, slip compensation function is invalid. After Flycatching is finished, this function is valid.

F137	Modes of torque compensation	Setting range: 0: Linear compensation; 1: Square compensation; 2: User-defined multipoint compensation 3: Auto torque compensation	Mfr's value: 3
F138	Linear compensation	Setting range: 1~20	Mfr's value: subject to inverter model
F139	Square compensation	Setting range: 1: 1.5 2: 1.8 3: 1.9 4: 2.0	Mfr's value: 1

When F106=2, the function of F137 is valid.

## 9-8 Function Parameters

To compensate low-frequency torque controlled by VVVF, output voltage of inverter while low-frequency should be compensated.

When F137=0, linear compensation is chosen and it is applied on universal constant-torque load;

When F137=1, square compensation is chosen and it is applied on the loads of fan or water pump;

When F137=2, user-defined multipoint compensation is chosen and it is applied on the special loads of spin-drier or centrifuge;

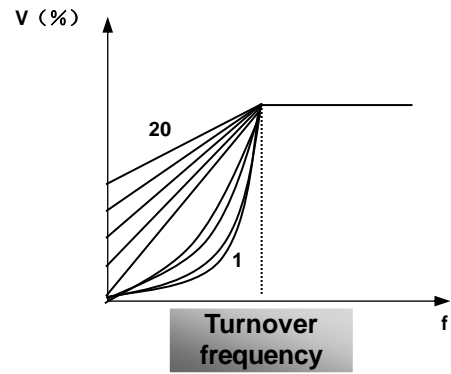

Figure 9-3 Torque Promotion

This parameter should be increased when the load is heavier, and this parameter should be decreased when the load is lighter.

If the torque is elevated too much, the motor overheats easily, and the current of inverter will be too high. Please check the motor while elevating the torque.

When F137=3, auto torque compensation is chosen and it can compensate low-frequency torque automatically, to diminish motor slip, to make rotor rotary speed close to synchro rotary speed and to restrain motor vibration. Customers should correctly set motor power, rotary speed, numbers of motor poles, motor rated current and stator resistance. Please refer to the chapter "Operation process of measuring motor parameters".

F140	User-defined frequency point F1	Setting range: 0~F142	Mfr's value: 1.00
F141	User-defined voltage point V1	Setting range: 0~100%	Mfr's value: 4
F142	User-defined frequency point F2	Setting range: F140~F144	Mfr's value:
F143	User-defined voltage point V2	Setting range: 0~100%	Mfr's value: 13
F144	User-defined frequency point F3	Setting range: F142~F146	Mfr's value:
F145	User-defined voltage point V3	Setting range: 0~100%	Mfr's value: 24
F146	User-defined frequency point F4	Setting range: F144~F148	Mfr's value:
F147	User-defined voltage point V4	Setting range: 0~100%	Mfr's value: 45
F148	User-defined frequency point F5	Setting range: F146~F150	Mfr's value:
F149	User-defined voltage point V5	Setting range: 0~100%	Mfr's value: 63
F150	User-defined frequency point F6	Setting range: F148~F118	Mfr's value:
F151	User-defined voltage point V6	Setting range: 0~100%	Mfr's value: 81

Multi-stage VVVF curves are defined by 12 parameters from F140 to F151.

The setting value of VVVF curve is set by motor load characteristic.

Note:  $V1 < V2 < V3 < V4 < V5 < V6$ ,  $F1 < F2 < F3 < F4 < F5 < F6$ . As low-frequency, if the setting voltage is too high, motor will overheat or be damaged. Inverter will be stalling or occur over-current protection.

Note: During the process of Flycatching, polygonal-line V/F curve function is invalid. After Flycatching is finished, this function is valid.

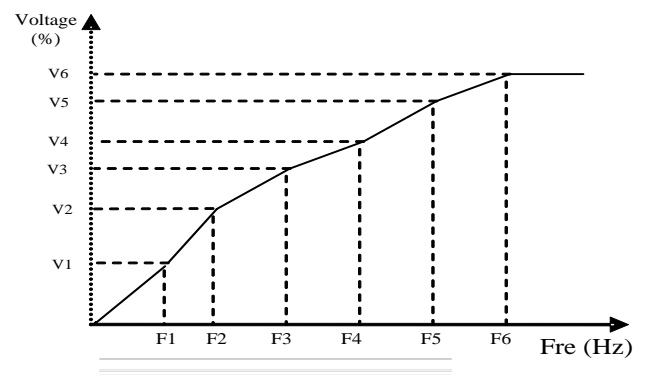

Figure 9-4 Polygonal-Line Type VVVF



F152 Output voltage corresponding to turnover frequency	Setting range: 0~100	Mfr's value: 100
---------------------------------------------------------	----------------------	------------------

This function can meet the needs of some special loads, for example, when the frequency outputs 300Hz and corresponding voltage outputs 200V (supposed voltage of inverter power supply is 400V), turnover frequency F118 should be set to 300Hz and F152 is set to  $(200 \div 400) \times 100 = 50$ . And F152 should be equal to 50.

Please pay attention to nameplate parameters of motor. If the working voltage is higher than rated voltage or the frequency is higher than rated frequency, motor would be damaged.

F153 Carrier frequency setting	Setting range: subject to inverter model	Mfr's value: subject to inverter model
--------------------------------	------------------------------------------	----------------------------------------

Carrier-wave frequency of inverter is adjusted by setting this code function. Adjusting carrier-wave may reduce motor noise, avoid point of resonance of mechanical system, decrease leakage current of wire to earth and the interference of inverter.

When carrier-wave frequency is low, although carrier-wave noise from motor will increase, the current leaked to the earth will decrease. The wastage of motor and the temperature of motor will increase, but the temperature of inverter will decrease.

When carrier-wave frequency is high, the situations are opposite, and the interference will raise.

When output frequency of inverter is adjusted to high frequency, the setting value of carrier-wave should be increased. Performance is influenced by adjusting carrier-wave frequency as below table:

Carrier-wave frequency	Low	→	High
Motor noise	Loud	→	Low
Waveform of output current	Bad	→	Good
Motor temperature	High	→	Low
Inverter temperature	Low	→	High
Leakage current	Low	→	High
Interference	Low	→	High

F154 Automatic voltage rectification	Setting range: 0: Invalid 1: Valid 2:Invalid during deceleration process	Mfr's value: 0
--------------------------------------	--------------------------------------------------------------------------	----------------

This function is enabled to keep output voltage constant automatically in the case of fluctuation of input voltage, but the deceleration time will be affected by internal PI adjustor. If deceleration time is forbidden being changed, please select F154=2.

F155 Digital secondary frequency setting	Setting range: 0~F111	Mfr's value: 0
F156 Digital secondary frequency polarity setting	Setting range: 0 or 1	Mfr's value: 0
F157 Reading secondary frequency		
F158 Reading secondary frequency polarity		

Under combined speed control mode, when secondary frequency source is digital setting memory (F204=0), F155 and F156 are considered as initial set values of secondary frequency and polarity (direction).

In the mode of combined speed control, F157 and F158 are used for reading the value and direction of secondary frequency.

For example, when F203=1, F204=0. F207=1, the given analog frequency is 15Hz, inverter is required to run to 20Hz. In case of this requirement, user can push "UP" button to raise the frequency from 15Hz to 20Hz. User can also set F155=5Hz and F160=0 (0 means forward, 1 means reverse). In this way, inverter can be run to 20Hz directly.

## 9-10 Function Parameters

F159 Random carrier-wave selection	Setting range: 0: Invalid 1: Valid	Mfr's value: 1
------------------------------------	------------------------------------------	----------------

When F159=0, inverter will modulate as per the carrier-wave set by F153. When F159=1, inverter will operate in mode of random carrier-wave modulating.

Note: when random carrier-wave is selected, output torque will increase but noise will be loud. When the carrier-wave set by F153 is selected, noise will be reduced, but output torque will decrease. Please set the value according to the situation.

F160 Reverting to manufacturer values	Setting range: 0: Invalid 1: Valid	Mfr's value: 0
---------------------------------------	------------------------------------------	----------------

When there is problem with inverter's parameters and manufacturer values need to be restored, set F160=1. After "Reverting to manufacturer values" is done, F160 values will be automatically changed to 0.

"Reverting to manufacturer values" will not work for the function-codes marked "o" in the "change" column of the parameters table. These function codes have been adjusted properly before delivery. It is recommended not to change them.

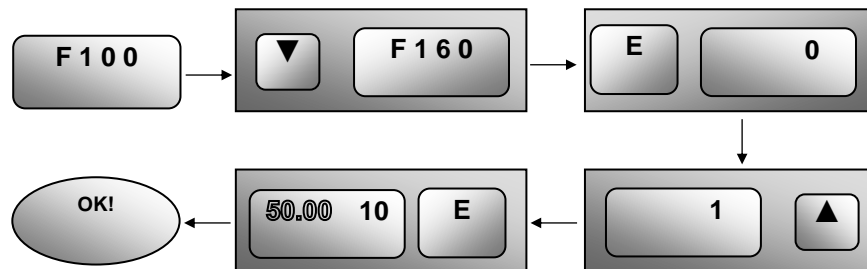

Figure 9-5 Reverting to Manufacturer Values

## 9.2 Operation Control

F200 Source of start command	Setting range: 0: Keypad command; 1: Terminal command; 2: Keypad+Terminal; 3: MODBUS; 4: Keypad+Terminal+MODBUS	Mfr's value: 4
F201 Source of stop command	Setting range: 0: Keypad command; 1: Terminal command; 2: Keypad+Terminal; 3: MODBUS; 4: Keypad+Terminal+MODBUS	Mfr's value: 4

F200 and F201 are the resource of selecting inverter control commands.

Inverter control commands include: starting, stopping, forward running, reverse running, jogging, etc.

"Keypad command" refers to the start/stop commands given by the "I" or "O" key on the keypad.

"Terminal command" refers to the start/stop command given by the "I" terminal defined by F316-F323.

When F200=3 and F201=3, the running command is given by MODBUS communication.

When F200=2 and F201=2, "keypad command" and "terminal command" are valid at the mean time, F200=4 and F201=4 are the same.

F202 Mode of direction setting	Setting range: 0: Forward running locking; 1: Reverse running locking; 2: Terminal setting	Mfr's value: 0
-----------------------------------	-----------------------------------------------------------------------------------------------------	-------------------

The running direction is controlled by this function code together with other speed control mode which can set the running direction of inverter. When auto-circulation speed is selected by F500=2, this function code is not valid.

When speed control mode without controlling direction is selected, the running direction of inverter is controlled by this function code, for example, keypad controls speed.

Direction given by F202	Direction given by other control mode	Running direction	Remarks
0	0	0	0 means forward. 1 means reverse.
0	1	1	
1	0	1	
1	1	0	

F203 Main frequency source X	Setting range: 0: Memory of digital given; 1: External analog AI1; 2: External analog AI2; 3: Reserved; 4: Stage speed control; 5: No memory of digital given; 6: Reserved; 7: Reserved; 8:Reserved; 9: PID adjusting; 1 0: MODBUS	Mfr's value: 0
---------------------------------	---------------------------------------------------------------------------------------------------------------------------------------------------------------------------------------------------------------------------------------------------------------------	----------------

Main frequency source is set by this function code.

**0:** Memory of digital given

Its initial value is the value of F113. The frequency can be adjusted through the key "up" or "down", or through the "up", "down" terminals.

## 9-12 Function Parameters

“Memory of digital given” means after inverter stops, the target frequency is the running frequency before stop. If the user would like to save target frequency in memory when the power is disconnected, please set F220=1, i.e. frequency memory after power down is valid.

**1:** External analog AI1; 2: External analog AI2

The frequency is set by analog input terminal AI1 and AI2. The analog signal may be current signal (0-20mA or 4-20mA) or voltage signal (0-5V or 0-10V), which can be chosen by switch code. Please adjust the switch code according to practical situations, refer to fig 4-4 and Table 8-2.

When inverters leave the factory, the analog signal of AI1 channel is DC voltage signal, the range of voltage is 0-10V, and the analog signal of AI2 channel is DC current signal, the range of current is 0-20 mA. If 4-20mA current signal is needed, please set lower limit of analog input F406=2, which input resistor is 500OHM. If some errors exist, please make some adjustments.

**4:** Stage speed control

Multi-stage speed control is selected by setting stage speed terminals F316-F322 and function codes of multi-stage speed section. The frequency is set by multi-stage terminal or automatic cycling frequency.

**5:** No memory of digital given

Its initial value is the value of F113. The frequency can be adjusted through the key “up” or “down”, or through the “up”, “down” terminals.

“No memory of digital given” means that the target frequency will restore to the value of F113 after stop no matter the state of F220.

**9:** PID adjusting

When PID adjusting is selected, the running frequency of inverter is the value of frequency adjusted by PID. Please refer to instructions of PID parameters for PID given resource, PID given numbers, feedback source, and so on.

**10:** MODBUS

The main frequency is given by MODBUS communication.

F204 Secondary frequency source Y	Setting range: 0: Memory of digital given; 1: External analog AI1; 2: External analog AI2; 3: Reserved; 4: Stage speed control; 5: PID adjusting; 6: Reserved;	Mfr's value: 0
-----------------------------------	-------------------------------------------------------------------------------------------------------------------------------------------------------------------------------------	----------------

When secondary frequency Y is given to channel as independent frequency, it has the same function with main frequency source X.

When F204=0, the initial value of secondary frequency is set by F155. When secondary frequency controls speed independently, polarity setting F156 is not valid.

When F207=1 or 3, and F204=0, the initial value of secondary frequency is set by F155, the polarity of frequency is set by F156, the initial value of secondary frequency and the polarity of secondary frequency can be checked by F157 and F158.

When the secondary frequency is set by analog input (AI1, AI2), the setting range for the frequency is set by F205 and F206.

When the secondary frequency is given by keypad potentiometer, the main frequency can only select stage speed control and modbus control (F203=4, 10)

Note: secondary frequency source Y and main frequency source X cannot use the same frequency given channel.

F205 reference for selecting secondary frequency source Y range	Setting range: 0: Relative to max frequency; 1: Relative to main frequency X	Mfr's value: 0
F206 secondary frequency Y range (%)	Setting range: 0~100	Mfr's value: 100

When combined speed control is adopted for frequency source, F206 is used to confirm the relative object of the setting range for the secondary frequency.

F205 is to confirm the reference of the secondary frequency range. If it is relative to main frequency, the range will change according to the change of main frequency X.

F207 Frequency source selecting	Setting range: 0: X; 1: X+Y; 2: X or Y (terminal switchover); 3: X or X+Y (terminal switchover); 4: Combination of stage speed and analog 5: X-Y 6: Reserved	Mfr's value: 0
---------------------------------	-----------------------------------------------------------------------------------------------------------------------------------------------------------------------------------	----------------

Select the channel of setting the frequency. The frequency is given by combination of main frequency X and secondary frequency Y.

When F207=0, the frequency is set by main frequency source.

When F207=1, X+Y, the frequency is set by adding main frequency source to secondary frequency source. X or Y can be given by PID.

When F207=2, main frequency source and secondary frequency source can be switched over by frequency source switching terminal.

When F207=3, main frequency given and adding frequency given(X+Y) can be switched over by frequency source switching terminal. X or Y cannot be given by PID.

When F207=4, stage speed setting of main frequency source has priority over analog setting of secondary frequency source (only suitable for F203=4 F204=1).

When F207=5, X-Y, the frequency is set by subtracting secondary frequency source from main frequency source. If the frequency is set by main frequency or secondary frequency, PID speed control cannot be selected.

Note:

When F203=4 and F204=1, the difference between F207=1 and F207=4 is that when F207=1, frequency source selecting is the addition of stage speed and analog, when F207=4, frequency source selecting is stage speed with stage speed and analog given at the same time. If stage speed given is cancelled and analog given still exists, inverter will run by analog given.

Frequency given mode can be switched over by selecting F207. For example: switching PID adjusting and normal speed control, switching stage speed and analog given, switching PID adjusting and analog given, and so on.

The acceleration/deceleration time of stage speed is set by function code of corresponding stage speed time. When combined speed control is adopted for frequency source, the acceleration/deceleration time is set by F114 and F115.

The mode of automatic cycle speed control is unable to combine with other modes.

When F207=2 (main frequency source and secondary frequency source can be switched over by terminals), if main frequency is not set to be under stage-speed control, secondary frequency can be set to be under automatic cycle speed control (F204=5, F500=0). Through the defined switchover terminal, the control mode (defined by X) and automatic cycle speed control (defined by Y) can be freely switched.

If the settings of main frequency and secondary frequency are the same, only main frequency will be valid.

# 9-14 Function Parameters

<p>F208 Terminal two-line/three-line operation control</p>	<p>Setting range: 0: No function 1: Two-line operation mode 1; 2: Two-line operation mode 2; 3: three-line operation mode 1; 4: three-line operation mode 2; 5: start/stop controlled by direction pulse</p>	<p>Mfr's value: 0</p>
----------------------------------------------------------------	--------------------------------------------------------------------------------------------------------------------------------------------------------------------------------------------------------------------------------------	-----------------------

When selecting two-line type or three-line type), F200, F201 and F202 are invalid.

Five modes are available for terminal operation control.

Note:

In case of stage speed control, set F208 to 0. If F208 ≠ 0 (when selecting two-line type or three-line type), F200, F201 and F202 are invalid.

“FWD”, “REV” and “X” are three terminals designated in programming DI1 ~ DI5.

**1:** Two-line operation mode 1: this mode is the most popularly used two-line mode. The running direction of mode is controlled by FWD, REV terminals.

For example: “FWD” terminal -----“open”: stop, “closed”: forward running;

“REV” terminal -----“open”: stop, “closed”: reverse running;

“CM” terminal -----common port

K1	K2	Running command
0	0	Stop
1	0	Forward running
0	1	Reverse running
1	1	Stop

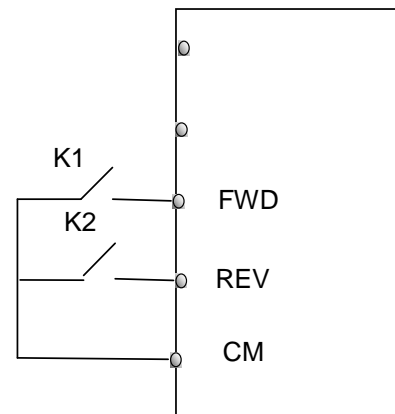

**2:** Two-line operation mode 2: when this mode is used, FWD is enable terminal, the direction is controlled by REV terminal.

For example: “FWD” terminal -----“open”: stop, “closed”: running;

“REV” terminal -----“open”: forward running, “closed”: reverse running;

“CM” terminal -----common port

K1	K2	Running command
0	0	Stop
0	1	Stop
1	0	Forward running
1	1	Reverse running

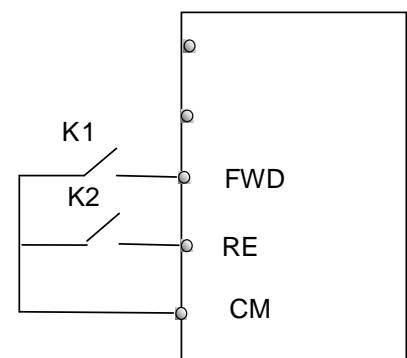

### 3: Three-line operation mode 1:

In this mode, X terminal is enable terminal, the direction is controlled by FWD terminal and REV terminal. Pulse signal is valid.

Stopping commands is enabled by opening X terminal.

SB3: Stop button

SB2: Forward button.

SB1: Reverse button.

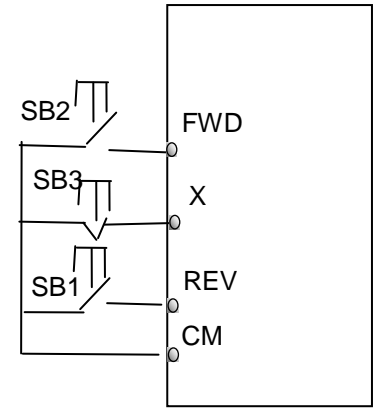

### 4: Three-line operation mode 2:

In this mode, X terminal is enable terminal, running command is controlled by FWD terminal. The running direction is controlled by REV terminal, and stopping command enable by opening X terminal.

SB1: Running button

SB2: Stop button

K1: direction switch. Open stands for forward running; close stands for reverse running.

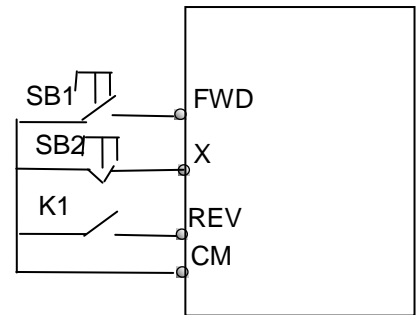

### 5: Start/stop controlled by direction pulse:

“FWD” terminal—(impulse signal: forward/stop)

“REV” terminal—(impulse signal: reverse/stop)

“CM” terminal—common port

Note: when pulse of SB1 triggers, inverter will run forward. When the

pulse triggers again, inverter will stop running.

When pulse of SB2 triggers, inverter will run reverse. When the pulse triggers again, inverter will stop running.

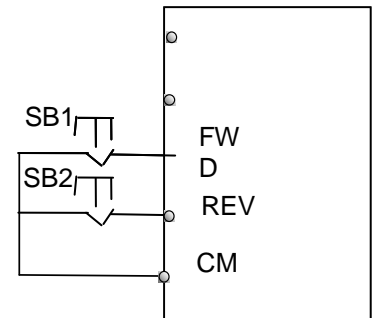

F209 Selecting the mode of stopping the motor	Setting range: 0: stop by deceleration time; 1: free stop(coast stop)	Mfr's value: 0
-----------------------------------------------	-----------------------------------------------------------------------------	----------------

When the stop signal is input, stopping mode is set by this function code:

F209=0: stop by deceleration time

Inverter will decrease output frequency according to setting acceleration/deceleration curve and decelerating time, after frequency decreases to 0, inverter will stop.

F209=1: free stop

After stop command is valid, inverter will stop output. Motor will free stop by mechanical inertia.

F210 Frequency display	Setting range:	Mfr's value: 0.01
------------------------	----------------	-------------------

## 9-16 Function Parameters

accuracy	0.01~2.00	
----------	-----------	--

Under keypad speed control or terminal UP/DOWN speed control, frequency display accuracy is set by this function code and the range is from 0.01 to 2.00. For example, when F210=0.5, ▲ /▼ terminal is pressed at one time, frequency will increase or decrease by 0.5Hz.

F211 Speed of digital control	Setting range: 0.01~100.0Hz/S	Mfr's value: 5.00
-------------------------------	----------------------------------	-------------------

When UP/DOWN terminal is pressed, frequency will change at the setting rate. The Mfr's value is 5.00Hz/s.

F212 Direction memory	Setting range: 0: Invalid 1: Valid	Mfr's value: 0
-----------------------	------------------------------------------	----------------

This function is valid when three-line operation mode 1 (F208=3) is valid.

When F212=0, after inverter is stopped, reset and repowered on, the running direction is not memorized.

When F212=1, after inverter is stopped, reset and repowered on, if inverter starts running but no direction signal, inverter will run according the memory direction.

F213 Auto-starting after repowered on	Setting range: 0: invalid; 1: valid	Mfr's value: 0
F214 Auto-starting after reset	Setting range: 0: invalid; 1: valid	Mfr's value: 0

Whether or not to start automatically after repowered on is set by F213

F213=1, Auto-starting after repowered on is valid. When inverter is power off and then powered on again, it will run automatically after the time set by F215 and according to the running mode before power-down. If F220=0 frequency memory after power-down is not valid, inverter will run by the setting value of F113.

F213=0, after repower-on, inverter will not run automatically unless running command is given to inverter.

·Whether or not to start automatically after fault resetting is set by F214

When F214=1, if fault occurs, inverter will reset automatically after delay time for fault reset (F217). After resetting, inverter will run automatically after the auto-starting delay time (F215).

If frequency memory after power-down (F220) is valid, inverter will run at the speed before power-down. Otherwise, inverter will run at the speed set by F113.

In case of fault under running status, inverter will reset automatically and auto-start. In case of fault under stopped status, the inverter will only reset automatically.

When F214=0, after fault occurs, inverter will display fault code, it must be reset manually.

F215 Auto-starting delay time	Setting range: 0.1~3000.0	Mfr's value: 60.0
-------------------------------	------------------------------	-------------------

F215 is the auto-starting delay time for F213 and F214. The range is from 0.1s to 3000.0s.

F216 Times of auto-starting in case of repeated faults	Setting range:	Mfr's value: 0
--------------------------------------------------------	----------------	----------------



## Function Parameters 9-17

	0~5	
F217 Delay time for fault reset	Setting range: 0.0~10.0	Mfr's value: 3.0
F219 Write EEPROM by Modbus	Setting range: 0: invalid; 1: valid	Mfr's value: 1

F216 sets the most times of auto-starting in case of repeated faults. If starting times are more than the setting value of this function code, inverter will not reset or start automatically after fault. Inverter will run after running command is given to inverter manually.

F217 sets delay time for fault reset. The range is from 0.0 to 10.0S which is time interval from fault to resetting.

F220 Frequency memory after power-down	Setting range: 0: invalid; 1: valid	Mfr's value: 0
----------------------------------------	-------------------------------------------	----------------

F220 sets whether or not frequency remember after power-down is valid.

This function is valid for F213 and F214. Whether or not to memory running state after power-down or malfunction is set by this function.

-The function of frequency memory after power-down is valid for main frequency and secondary frequency that is given by digital. Because the digital given secondary frequency has positive polarity and negative polarity, it is saved in the function codes F155 and F156.

Table 9-1 Combination of Speed Control

F204 F203	0. Memory of digital setting	1 External analog AI1	2 External analog AI2	4 Terminal stage speed control	5 PID adjusting
0 Memory of digital setting	○	●	●	●	●
1 External analog AI1	●	○	●	●	●
2 External analog AI2	●	●	○	●	●
4 Terminal Stage speed control	●	●	●	○	●
5 Digital setting	○	●	●	●	●
9 PID adjusting	●	●	●	●	○
10 MODBUS	●	●	●	●	●

●: Inter-combination is allowable.

○: Combination is not allowable.

The mode of automatic cycle speed control is unable to combine with other modes. If the combination includes the mode of automatic cycle speed control, only main speed control mode will be valid.

F224 when target frequency is lower than Min frequency	Setting range: 0: stop 1: run at min frequency	Mfr's value: 1
--------------------------------------------------------	------------------------------------------------	----------------

F224=1, when target frequency is lower than Min frequency, inverter will run at Min frequency.

# 9-18 Function Parameters

F228	Application selection	Setting range: 0: Invalid 1: Basic speed control 2: Auto/manual speed control 3: Preset speed control 4: Terminal speed control 5: PID control	Mfr's value: 0
------	-----------------------	------------------------------------------------------------------------------------------------------------------------------------------------------------------	----------------

F228 can be set to Mfr's value by F160=1.

## 9.3 Multifunctional Input and Output Terminals

### 9.3.1 Digital multifunctional output terminals

F300	Relay token output	Setting range: 0~40  <a href="#">Refer to</a> Table 9-2 for detailed instructions.	Mfr's value: 1
F301	DO1 token output		Mfr's value: 14

Table 9-2 Instructions for digital multifunctional output terminal

Value	Function	Instructions
0	No function	Output terminal has no functions.
1	Inverter fault protection	When inverter trips this signal is output high.
2	Over latent frequency 1	Please refer to instructions from F307 to F309.
3	Over latent frequency 2	Please refer to instructions from F307 to F309.
4	Free stop	Under free stop status, after stop command is given, ON signal is output until inverter completely stops.
5	In running status 1	Indicating that inverter is running and ON signal is output.
6	DC braking	Indicating that inverter is in the status of DC braking and ON signal is output.
7	Acceleration/deceleration time switchover	Indicating that inverter is in the status of acceleration/deceleration time switchover
8	Reserved	
9	Reserved	
10	Inverter overload pre-alarm Stall Warning	After inverter overloads, ON signal is output after the half time of protection timed, ON signal stops outputting after overload stops or overload protection occurs.
11	Motor overload pre-alarm	After motor overloads, ON signal is output after the half time of protection timed, ON signal stops

## Function Parameters 9-19

Value	Function	Instructions
		outputting after overload stops or overload protection occurs.
12	Stalling	During accel/decel process, inverter stops accelerating/decelerating because inverter is stalling, and ON signal is output.
13	Inverter is ready to run	When inverter is powered on. Protection function is not in action and inverter is ready to run, then ON signal is output.
14	In running status 2	Indicating that inverter is running and ON signal is output. When inverter is running at 0HZ, its seen as the running status, and ON signal is output.
15	Frequency arrival output At Speed	Indicating inverter runs at the setting target frequency, and ON signal is output. See F312.
16	Overheat pre-alarm Warning	When testing temperature reaches 80% of setting value, ON signal is output. When overheat protection occurs or testing value is lower than 80%of setting value, ON signal stops outputting.
17	Over latent current output	When output current of inverter reaches the setting overlantent current, ON signal is output. See F310 and F311.
18	Analog line disconnection protection	Indicating inverter detects analog input lines disconnection, and ON signal is output refer to F741.
19	Reserved	
20	Zero current detecting output	When inverter output current has fallen to zero current detecting value, and after the setting time of F755, ON signal is output, refer to F754 and F755.
21	DO1 Output controlled by PC/PLC	1 means output is valid. 0 means output is invalid.
22	Reserved	
23	TA\TC Output controlled by PC/PLC	
24	Watchdog token output	The token output is valid when inverter trips into Err6.
25-39	Reserved	
40	Switchover of high-frequency performance	When this function is valid, inverter will switch into high-frequency optimizing mode.

## 9-20 Function Parameters

F307 Characteristic frequency 1	Setting range: F112~F111Hz	Mfr's value: 10.00Hz
F308 Characteristic frequency 2		Mfr's value: 50.00Hz
F309 Characteristic frequency width	Setting range: 0~100%	Mfr's value: 50

When F300=2, 3, F301=2, 3 and F302=2, 3 and token characteristic frequency is selected, this group function codes set characteristic frequency and its width. For example: setting F301=2, F307=10, F309=10, when frequency is higher than F307, DO1 outputs ON signal. When frequency is lower than  $(10-10*10\%) = 9\text{Hz}$ , DO1 outputs OFF signal.

F310 Characteristic current	Setting range: 0~1000	Mfr's value: Rated current
F311 Characteristic current width	Setting range: 0~100	Mfr's value: 10

When F300=17 or F301=17 or token characteristic current is selected, this group function codes set characteristic current and its width.

For example: setting F301=17, F310=100, F311=10, when inverter current is higher than F310, DO1 outputs ON signal. When inverter current is lower than  $(100-100*10\%) = 90\text{A}$ , DO1 outputs OFF signal.

F312 Frequency arrival threshold At Speed	Setting range: 0.00~5.00Hz	Mfr's value: 0.00
-------------------------------------------	----------------------------	-------------------

When F300=15 or F301=15, threshold range is set by F312.

For example: when F301=15, target frequency is 20HZ and F312=2, the running frequency reaches 18Hz  $(20-2)$ , ON signal is output by DO1 until the running frequency reaches target frequency.

## 9.3.2 Digital multifunctional input terminals

F316	DI1 terminal function setting	Setting range: 0: no function 1: Run 2: Stop 3: multi-stage speed 1 4: multi-stage speed 2 5: multi-stage speed 3 6: multi-stage speed 4 7: reset 8: free stop 9: external emergency stop 10: acceleration/deceleration forbidden 11: forward run jogging 12: reverse run jogging 13: UP frequency increasing terminal 14: DOWN frequency decreasing terminal 15: "FWD" terminal 16: "REV" terminal 17: three-line type input "X" terminal 18: acceleration/deceleration time switchover 1 19: Reserved 20: switchover between speed and torque 21: frequency source switchover terminal 32: Fire pressure switchover 33: Emergency fire control 34: Acceleration / deceleration switchover 2 37: Common-open PTC heat protection 38: Common-close PTC heat protection 48: High-frequency switchover 52: Jogging (no direction) 53: Watchdog 54: Frequency reset 55: switchover between manual running and auto running 56: Manual running 57: Auto running 58: Direction	Mfr's value: 11
F317	DI2 terminal function setting		Mfr's value: 9
F318	DI3 terminal function setting		Mfr's value: 15
F319	DI4 terminal function setting		Mfr's value: 16
F320	DI5 terminal function setting		Mfr's value: 7

This parameter is used for setting the corresponding function for multifunctional digital input terminal.

Both free stop and external emergency stop of the terminal have the highest priority.

Table 9-3 Instructions for digital multifunctional input terminal

Value	Function	Instructions
0	No function	Even if signal is input, inverter will not work. This function can be set by undefined terminal to prevent mistake action.
1	Running terminal	When running command is given by terminal or terminals combination and this terminal is valid, inverter will run. This terminal has the same function with "I" key in keypad.
2	Stop terminal	When stop command is given by terminal or terminals combination and this terminal is valid, inverter will stop. This terminal has the same function with "stop" key in keypad.

## 9-22 Function Parameters

Value	Function	Instructions
3	Multistage speed terminal 1	15-stage speed is realized by combination of this group of terminals. See Table 9-5.
4	Multistage speed terminal 2	
5	Multistage speed terminal 3	
6	Multistage speed terminal 4	
7	Reset terminal	This terminal has the same function with “O” key in keypad.
8	Free stop terminal Coast Stop	Inverter closes off output and motor stop process is not controlled by inverter. This mode is often used when load has big inertia or there are no requirements for stop time. This mode has the same function with free stop of F209.
9	External emergency stop terminal	When external malfunction signal is given to inverter, malfunction will occur and inverter will stop.
10	Acceleration/deceleration forbidden terminal Speed Hold	Inverter will not be controlled by external signal (except for stop command), and it will run at the current output frequency.
11	Forward run jogging	Forward jogging running and reverse jogging running. Refer to F124, F125 and F126 for jogging running frequency, jogging acceleration/deceleration time.
12	Reverse run jogging	
13	UP frequency increasing terminal	When frequency source is set by digital given, the setting frequency can be adjusted which rate is set by F211.
14	DOWN frequency decreasing terminal	
15	“FWD” terminal	When start/stop command is given by terminal or terminals combination, running direction of inverter is controlled by external terminals.
16	“REV” terminal	
17	Three-line input “X” terminal	“FWD”、 “REV”、 “CM” terminals realize three-line control. See F208 for details.
18	Acceleration/deceleration time switchover 1	If this function is valid, the second acceleration/deceleration time will be valid. Please refer to F116 and F117.
21	Frequency source switchover terminal	When F207=2, main frequency source and secondary frequency source can be switched over by frequency source switching terminal. When F207=3, X and (X + Y) can be switched over by frequency source switching terminal.
32	Fire pressure switchover	When PID control is valid and this terminal is valid, the setting value of PID switches into fire pressure given (FA58).
33	Emergency fire control	When emergency fire mode (FA59) is valid, inverter will be in emergency fire mode.
34	Acceleration / deceleration switchover 2	Please refer to Table 9-4.
48	High-frequency switchover	When this function is valid, inverter will switch into high-frequency optimizing mode.
37	Common-open PTC heat protection	When this function is valid, common-open heat relay is externally connected. When common-open contact is closed and inverter is in the running status, inverter will trip into OH1.

Value	Function	Instructions
38	Common-close PTC heat protection	When this function is valid, common-close heat relay is externally connected. When common-close contact is open and inverter is in the running status, inverter will trip into OH1.
52	Jogging (no direction)	In the application 1 and 2, the direction of jogging command is controlled by terminal set to 58: direction.
53	Watchdog	During the time set by F326 elapses without an impulse being registered, inverter will trip into Err6, and inverter will stop according to stop mode set by F327.
54	Frequency reset	In the application 4, if the function is valid, target frequency will change to the value set by F113.
55	Switchover between manual run and auto run	In the application 2, the function is used to switch manual run and auto run.
56	Manual run	In the application 2, if the function is valid, inverter will run manually.
57	Auto running	In the application 2, if the function is valid, inverter will run automatically.
58	Direction	In the application 1 and 2, the function is used to give direction. When the function is valid, inverter will run reverse. Or else, inverter will run forward.

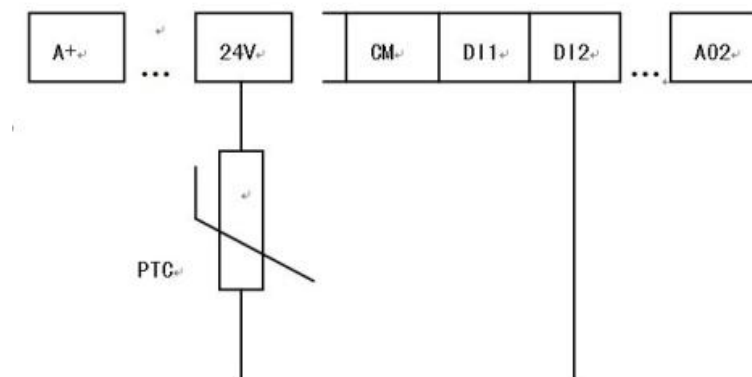

Figure 9-6 PTC Heat Protection

When the coding switch is in the end of “NPN”, PTC resistor should be connected between CM and D1x terminal. When the coding switch is in the end of “PNP”, PTC resistor should be connected between D1x and 24V. The recommended resistor value is 16.5KΩ.

Because the accuracy of external PTC has some differences with manufacture variation some errors can exist, thermistor protection relay is recommended.

NOTE: To use this function double insulate motor thermistor must be used.

## 9-24 Function Parameters

Table 9-4 Accel/decel selection

Accel/decel switchover 2 (34)	Accel/decel switchover 1 (18)	Present accel/decel time	Related parameters
0	0	The first accel/decel time	F114, F115
0	1	The second accel/decel time	F116, F117
1	0	The third accel/decel time	F277, F278
1	1	The fourth accel/decel time	F279, F280

Table 9-5 Instructions for multistage speed

K4	K3	K2	K1	Frequency setting	Parameters
0	0	0	0	Multi-stage speed 1	F504/F519/F534/F549/F557/F565
0	0	0	1	Multi-stage speed 2	F505/F520/F535/F550/F558/F566
0	0	1	0	Multi-stage speed 3	F506/F521/F536/F551/F559/F567
0	0	1	1	Multi-stage speed 4	F507/F522/F537/F552/F560/F568
0	1	0	0	Multi-stage speed 5	F508/F523/F538/F553/F561/F569
0	1	0	1	Multi-stage speed 6	F509/F524/F539/F554/F562/F570
0	1	1	0	Multi-stage speed 7	F510/F525/F540/F555/F563/F571
0	1	1	1	Multi-stage speed 8	F511/F526/F541/F556/F564/F572
1	0	0	0	Multi-stage speed 9	F512/F527/F542/F573
1	0	0	1	Multi-stage speed 10	F513/F528/F543/F574
1	0	1	0	Multi-stage speed 11	F514/F529/F544/F575
1	0	1	1	Multi-stage speed 12	F515/F530/F545/F576
1	1	0	0	Multi-stage speed 13	F516/F531/F546/F577
1	1	0	1	Multi-stage speed 14	F517/F532/F547/F578
1	1	1	0	Multi-stage speed 15	F518/F533/F548/F579
1	1	1	1	None	None

Note: 1. K4 is multi-stage speed terminal 4, K3 is multi-stage speed terminal 3, K2 is multi-stage speed terminal 2, K1 is multi-stage speed terminal 1. And 0 stands for OFF, 1 stands for ON.

0=OFF, 1=ON

F326	Watchdog time	Setting range: 0.0~3000.0	Mfr's value: 10.0
F327	Stop mode	Setting range: 0: Free to stop : Deceleration to stop	Mfr's value : 0

When F326=0.0, watchdog function is invalid.

When F327=0, and during the time set by F326 elapses without an impulse being registered, inverter will free to stop and it will trip into Err6.

When F327=1, and during the time set by F326 elapses without an impulse being registered, inverter will deceleration to stop, then inverter will trip into Err6.



F324 Free stop terminal logic	Setting range: 0: positive logic (valid for low level); 1: negative logic (valid for high level)	Mfr's value: 0
F325 External emergency stop terminal logic		Mfr's value: 0
F328 Terminal filtering times	Setting range: 1~100	Mfr's value: 10

When multi-stage speed terminal is set to free stop terminal (8) and external emergency stop terminal (9), terminal logic level is set by this group of function codes. When F324=0 and F325=0, positive logic and low level is valid, when F324=1 and F325=1, negative logic and high level is valid.

F330 Diagnostics of DIX terminal	Only read
----------------------------------	-----------

F330 is used to display the diagnostics of DIX terminals.

Please refer to Figure 9-7 about the DIX terminals diagnostics in the first digit.

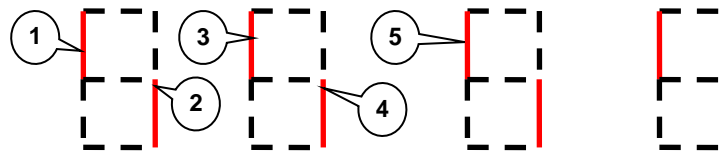

Figure 9-7 Status of digital input terminal

- ① stands for DI1 valid.
- ② stands for DI2 valid.
- ③ stands for DI3 valid.
- ④ stands for DI4 valid.
- ⑤ stands for DI5 valid.

### 9.3.3 Analog input monitoring

F331 Monitoring AI1	Only read
F332 Monitoring AI2	Only read

The value of analog is displayed by 0~4095.

F335	Relay output simulation	Setting range: 0: Output active 1: Output inactive.	Mfr's value: 0
F336	DO1 output simulation		Mfr's value: 0

Take an example of DO1 output simulation, when inverter is in the stop status and enter F336, press the UP key, the DO1 terminal is valid. Relax the UP key, DO1 remains valid status. After quitting F336, DO1 will revert to initial output status.

F338	AO1 output simulation	Setting range: 0~4095	Mfr's value: 0
------	-----------------------	-----------------------	----------------

When inverter is in the stop status, and enter F338, press the UP key, the output analog will increase, and when press the DOWN key, the output analog will decrease. After quitting the parameters, AO1 will revert to initial output status.

## 9-26 Function Parameters

F340 Selection of terminal negative logic	Setting range: 0: Invalid 1: DI1 negative logic 2: DI2 negative logic 4: DI3 negative logic 8: DI4 negative logic 16: DI5 negative logic	Mfr's value: 0
-------------------------------------------	------------------------------------------------------------------------------------------------------------------------------------------------------------	----------------

For example if user wants to set DI1 and DI4 to negative logic, set F340=1+8=9

### 9.4 Analog Input and Output

AC10 series inverters have 2 analog input channels and 2 analog output channels.

F400 Lower limit of AI1 channel input (V)	Setting range: 0.00~F402	Mfr's value: 0.01V
F401 Corresponding setting for lower limit of AI1 input	Setting range: 0~F403	Mfr's value: 1.00
F402 Upper limit of AI1 channel input (V)	Setting range: F400~10.00	Mfr's value: 10.00
F403 Corresponding setting for upper limit of AI1 input	Setting range: Max (1.00, F401) ~2.00	Mfr's value: 2.00
F404 AI1 channel proportional gain K1	Setting range: 0.0~10.0	Mfr's value: 1.0
F405 AI1 filtering time constant (S)	Setting range: 0.1~10.0	Mfr's value: 0.10

In the mode of analog speed control, sometimes it is required to adjust the relationship between the upper limit and lower limit of the value input analog, analog changes and the output frequency, to achieve a satisfactory speed control effect.

The upper and lower limit of analog input are set by F400 and F402.

For example: when F400=1, F402=8, if analog input voltage is lower than 1V, system judges it as 0. If input voltage is higher than 8V, system judges it as 10V (suppose analog channel selects 0-10V). If Max frequency F111 is set to 50Hz, the output frequency corresponding to 1-8V is 0-50Hz.

The filtering time constant is set by F405.

The greater the filtering time constant is, the more stable for the analog testing. However, the precision may decrease to a certain extent. It may require appropriate adjustment according to actual application.

Channel proportional gain is set by F404.

If 1V corresponds to 10Hz and F404=2, then 1V will correspond to 20Hz.

Corresponding setting for upper / lower limit of analog input are set by F401 and F403.

If Max frequency F111 is 50Hz, analog input voltage 0-10V can correspond to output frequency from -50Hz to 50Hz by setting these group function codes. Please set F401=0 and F403=2, then 0V corresponds to -50Hz, 5V corresponds to 0Hz and 10V corresponds to 50Hz. The unit scaling the upper / lower limit of input is in percentage (%). If the value is greater than 1.00, it is positive; if the value is less than 1.00, it is negative. (e.g. F401=0.5 represents -50%).

If the running direction is set to forward running by F202, then 0-5V corresponding to the minus frequency will cause reverse running, or vice versa.

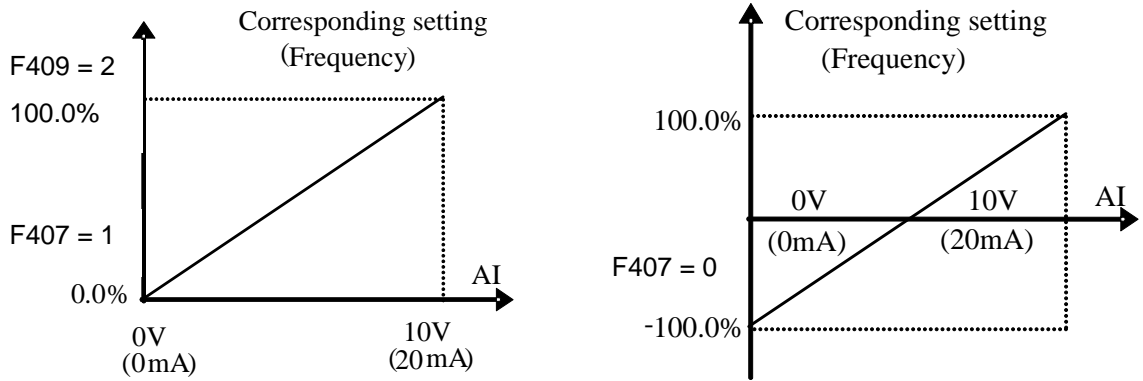
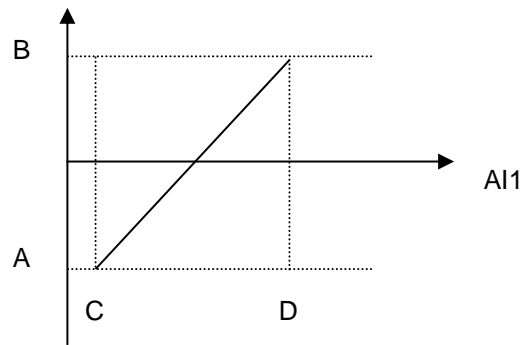

Figure 9-8 Correspondence of analog input to setting

The unit of for scaling the upper / lower limit of input is in percentage (%). If the value is greater than 1.00, it is positive; if the value is less than 1.00, it is negative. (e.g. F401=0.5 represents -50%).

The corresponding setting benchmark: in the mode of combined speed control, analog is the secondary frequency and the setting benchmark for range of secondary frequency which relatives to main frequency is “main frequency X”; corresponding setting benchmark for other cases is the “max frequency”, as illustrated in the right figure:



- A= (F401-1)\* should be max frequency fill
- B= (F403-1)\* should be max frequency fill
- C= F400
- D= F402

F406	Lower limit of AI2 channel input (V)	Setting range: 0.00~F408	Mfr's value: 0.01
F407	Corresponding setting for lower limit of AI2 input	Setting range: 0~F409	Mfr's value: 1.00
F408	Upper limit of AI2 channel input (V)	Setting range: F406~10.00	Mfr's value: 10.00
F409	Corresponding setting for upper limit of AI2 input	Setting range: Max (1.00, F407) ~2.00	Mfr's value: 2.00
F410	AI2 channel proportional gain K2	Setting range: 0.0~10.0	Mfr's value: 1.0
F411	AI2 filtering time constant (S)	Setting range: 0.1~50.0	Mfr's value: 0.1

The function of AI2 is the same with AI1.

F418	AI1 channel 0Hz voltage dead zone	Setting range: 0~0.50V (Positive-Negative)	Mfr's value: 0.00
F419	AI2 channel 0Hz voltage dead zone	Setting range: 0~0.50V (Positive-Negative)	Mfr's value: 0.00

Analog input voltage 0-5V can correspond to output frequency -50Hz-50Hz (2.5V corresponds to 0Hz) by setting the function of corresponding setting for upper / lower limit of analog input. The group function codes of F418 and F419 set the voltage range corresponding to 0Hz. For example, when F418=0.5 and F419=0.5, the voltage range from (2.5-0.5=2) to (2.5+0.5=3) corresponds to

## 9-28 Function Parameters

0Hz. So if F418=N and F419=N, then  $2.5 \pm N$  should correspond to 0Hz. If the voltage is in this range, inverter will output 0Hz.

0HZ voltage dead zone will be valid when corresponding setting for lower limit of input is less than 1.00.

F421 Panel selection	Setting range: 0: Local keypad panel 1: Remote control keypad panel 2: local keypad + remote control keypad	Mfr's value: 1
----------------------	-------------------------------------------------------------------------------------------------------------------	----------------

F421 is set to 0, local keypad panel is working. When F421 is set to 1, remote control keypad panel is working, and local keypad panel will be invalid for saving energy.

The remote control panel is connected by 8-cores net cable.

AC10 can supply one analog output channel AO1.

F423 AO1 output range	Setting range: 0: 0~5V; 1: 0~10V or 0~20mA 2: 4~20mA	Mfr's value: 1
F424 AO1 lowest corresponding frequency (Hz)	Setting range: 0.0~F425	Mfr's value: 0.05
F425 AO1 highest corresponding frequency (Hz)	Setting range: F424~F111	Mfr's value: 50.00
F426 AO1 output compensation (%)	Setting range: 0~120	Mfr's value: 100

AO1 output range is selected by F423. When F423=0, AO1 output range selects 0-5V, and when F423=1, AO1 output range selects 0-10V or 0-20mA. When F423=2, AO1 output range selects 4-20mA (When AO1 output range selects current signal, please turn the switch J5 to "I" position).

Correspondence of output voltage range (0-5V or 0-10V) to output frequency is set by F424 and F425. For example, when F423=0, F424=10 and F425=120, analog channel AO1 outputs 0-5V and the output frequency is 10-120Hz.

AO1 output compensation is set by F426. Analog excursion can be compensated by setting F426.

F431 AO1 analog output signal selecting	Setting range: 0: Running frequency; 1: Output current; 2: Output voltage; 3: Analog AI1; 4: Analog AI2; 6: Output torque; 7: Given by PC/PLC; 8: Target frequency	Mfr's value: 0
-----------------------------------------	--------------------------------------------------------------------------------------------------------------------------------------------------------------------------------------------	----------------

When output current is selected, analog output signal is from 0 to twice rated current.

When output voltage is selected, analog output signal is from 0V to rated output voltage.

F433 Corresponding current for full range of external voltmeter	Setting range: 0.01~5.00 times of rated current	Mfr's value: 2.00
F434 Corresponding current for full range of external ammeter		Mfr's value: 2.00

In case of F431=1 and AO1 channel for token current, F433 is the ratio of measurement range

of external voltage type ammeter to rated current of the inverter.

For example: measurement range of external ammeter is 20A, and rated current of the inverter is 8A, then,  $F433=20/8=2.50$ .

F437 Analog filter width	Setting range: 1~100	Mfr's value:10
--------------------------	----------------------	----------------

The greater the setting value of F437 is, the steadier the detecting analog is, but the response speed will decrease. Please set it according to the actual situations.

F460 AI1 channel input mode	Setting range: 0: straight line mode 1: folding line mode	Mfr's value: 0
F461 AI2 channel input mode	Setting range: 0: straight line mode 1: folding line mode	Mfr's value: 0
F462 AI1 insertion point A1 voltage value (V)	Setting range: F400~F464	Mfr's value: 2.00
F463 AI1 insertion point A1 setting value	Setting range: F401~F465	Mfr's value: 1.20
F464 AI1 insertion point A2 voltage value (V)	Setting range: F462~F466	Mfr's value: 5.00
F465 AI1 insertion point A2 setting value	Setting range: F463~F467	Mfr's value: 1.50
F466 AI1 insertion point A3 voltage value (V)	Setting range: F464~F402	Mfr's value: 8.00
F467 AI1 insertion point A3 setting value	Setting range: F465~F403	Mfr's value: 1.80
F468 AI2 insertion point B1 voltage value (V)	Setting range: F406~F470	Mfr's value: 2.00
F469 AI2 insertion point B1 setting value	Setting range: F407~F471	Mfr's value: 1.20
F470 AI2 insertion point B2 voltage value (V)	Setting range: F468~F472	Mfr's value: 5.00
F471 AI2 insertion point B2 setting value	Setting range: F469~F473	Mfr's value: 1.50
F472 AI2 insertion point B3 voltage value (V)	Setting range: F470~F412	Mfr's value: 8.00
F473 AI2 insertion point B3 setting value	Setting range: F471~F413	Mfr's value: 1.80

When analog channel input mode selects straight-line, please set it according to the parameters from F400 to F429. When folding line mode is selected, three points A1(B1), A2(B2), A3(B3) are inserted into the straight line, each of which can set the according frequency to input voltage. Please refer to Figure 9-9:

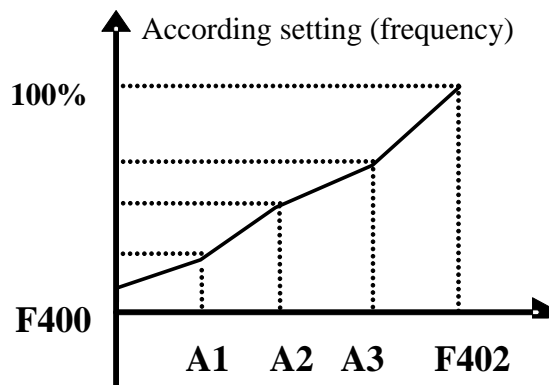

Figure 9-9 Folding analog with setting value

F400 and F402 are lower/upper limit of analog AI1 input. When  $F460=1$ ,  $F462=2.00V$ ,  $F463=1.4$ ,  $F111=50$ ,  $F203=1$ ,  $F207=0$ , then A1 point corresponding frequency is  $(F463-1) * F111=20Hz$ , which means 2.00V corresponding to 20Hz. The other points can be set by the same way.

# 9-30 Function Parameters

## 9.5 Multi-stage Speed Control

The function of multi-stage speed control is equivalent to a built-in PLC in the inverter. This function can set running time, running direction and running frequency.

AC10 series inverter can achieve 15-stage speed control and 8-stage speed auto circulating.

During the process of Flycatching, multi-stage speed control is invalid. After Flycatching is finished, inverter will run to target frequency according to the setting value of parameters.

F500	Stage speed type	Setting range: 0: 3-stage speed; 1: 15-stage speed; 2: Max 8-stage speed auto circulating	Mfr's value: 1
------	------------------	----------------------------------------------------------------------------------------------------	----------------

In case of multi-stage speed control (F203=4), the user must select a mode by F500. When F500=0, 3-stage speed is selected. When F500=1, 15-stage speed is selected. When F500=2, max 8-stage speed auto circulating is selected. When F500=2, "auto circulating" is classified into "2-stage speed auto circulating", "3-stage speed auto circulating", ... "8-stage speed auto circulating", which is to be set by F501.

Table 9-6 Selection of Stage Speed Running Mode

F203	F500	Mode of Running	Description
4	0	3-stage speed control	The priority in turn is stage-1 speed, stage-2 speed and stage-3 speed. It can be combined with analog speed control. If F207=4, "3-stage speed control" is prior to analog speed control.
4	1	15-stage speed control	It can be combined with analog speed control. If F207=4, "15-stage speed control" is prior to analog speed control.
4	2	Max 8-stage speed auto circulating	Adjusting the running frequency manually is not allowable. "2-stage speed auto circulating", "3-stage speed auto circulating", ... "8-stage speed auto circulating" may be selected through setting the parameters.

F501	Selection of Stage Speed Under Auto-circulation Speed Control	Setting range: 2~8	Mfr's value: 7
F502	Selection of number of cycles of Auto-circulation Speed Control	Setting range: 0~9999 (when the value is set to 0, the inverter will carry out infinite circulating)	Mfr's value: 0
F503	Status After Auto-circulation Running Finished.	Setting range: 0: Stop 1: Keep running at last-stage speed	Mfr's value: 0

If running mode is auto-circulation speed control (F203=4 and F500=2), please set the related parameters by F501~F503.

The inverter runs at the preset stage speed one by one under the auto-circulation speed control is called as cycle.

If F502=0, inverter will run at infinite auto circulation, which will be stopped by "stop" signal.

If F502>0, inverter will run at auto circulation conditionally. When auto circulation of the preset cycles is finished continuously (set by F502), inverter will finish auto-circulation running conditionally. When inverter keeps running and the preset cycles is not finished, if inverter receives "stop command", inverter will stop. If inverter receives "run command" again, inverter will automatically circulate by the setting time of F502.

If F503=0, then inverter will stop after auto circulation is finished. If F503=1, then inverter will

run at the speed of the last-stage after auto-circulation is finished as follows:

e.g., F501=3, then inverter will run at auto circulation of 3-stage speed;

F502=100, then inverter will run 100 cycles of auto circulation;

F503=1, inverter will run at the speed of the last stage after the auto-circulation running is finished.

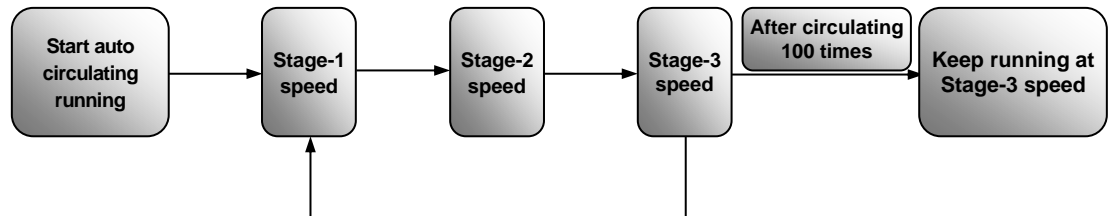

Figure 9-10 Auto-circulating Running

The inverter can be stopped by pressing “O” or sending “O” signal through terminal during auto-circulation running.

F504	Frequency setting for stage 1 speed (Hz)	Setting range: F112~F111	Mfr's value: 5.00	
F505	Frequency setting for stage 2 speed (Hz)		Mfr's value: 10.00	
F506	Frequency setting for stage 3 speed (Hz)		Mfr's value: 15.00	
F507	Frequency setting for stage 4 speed (Hz)		Mfr's value: 20.00	
F508	Frequency setting for stage 5 speed (Hz)		Mfr's value: 25.00	
F509	Frequency setting for stage 6 speed (Hz)		Mfr's value: 30.00	
F510	Frequency setting for stage 7 speed (Hz)		Mfr's value: 35.00	
F511	Frequency setting for stage 8 speed (Hz)		Mfr's value: 40.00	
F512	Frequency setting for stage 9 speed (Hz)		Mfr's value: 5.00	
F513	Frequency setting for stage 10 speed (Hz)		Mfr's value: 10.00	
F514	Frequency setting for stage 11 speed (Hz)		Mfr's value: 15.00	
F515	Frequency setting for stage 12 speed (Hz)		Mfr's value: 20.00	
F516	Frequency setting for stage 13 speed (Hz)		Mfr's value: 25.00	
F517	Frequency setting for stage 14 speed (Hz)		Mfr's value: 30.00	
F518	Frequency setting for stage 15 speed (Hz)		Mfr's value: 35.00	
F519~F533	Acceleration time setting for the speeds from Stage 1 to Stage 15 (S)		Setting range: 0.1~3000	Subject to inverter model
F534~F548	Deceleration time setting for the speeds from Stage 1 to Stage 15 (S)		Setting range: 0.1~3000	
F549~F556	Running directions of stage speeds from Stage 1 to Stage 8		Setting range: 0: forward running; 1: reverse running	Mfr's value: 0
F573~F579	Running directions of stage speeds from stage 9 to stage 15	Setting range: 0: forward running; 1: reverse running	Mfr's value: 0	

## 9-32 Function Parameters

F557~564	Running time of stage speeds from Stage 1 to Stage 8 (S)	Setting range: 0.1~3000	Mfr's value: 1.0
F565~F572	Stop time after finishing stages from Stage 1 to Stage 8 (S)	Setting range: 0.0~3000	Mfr's value: 0.0

### 9.6 Auxiliary Functions

F600	DC Braking Function Selection	Setting range: 0: Invalid; 1: braking before starting; 2: braking during stopping; 3: braking during starting and stopping	Mfr's value: 0
F601	Initial Frequency for DC Braking (Hz)	Setting range: 0.20~5.00	Mfr's value: 1.00
F602	DC Braking efficiency before Starting	Setting range: 0~100	Mfr's value: 10
F603	DC Braking efficiency During Stop		
F604	Duration of Braking Before Starting (S)	Setting range: 0.0~10.0	Mfr's value: 0.5
F605	Duration of Braking During Stopping (S)		

When F600=0, DC braking function is invalid.

When F600=1, braking before starting is valid. After the right starting signal is input, inverter starts DC braking. After braking is finished, inverter will run from the initial frequency.

In some applications, such as fan, motor is running at a low speed or in a reverse status, if inverter starts immediately, OC malfunction will occur. Adopting "braking before starting" will ensure that the fan stays in a static state before starting to avoid this malfunction.

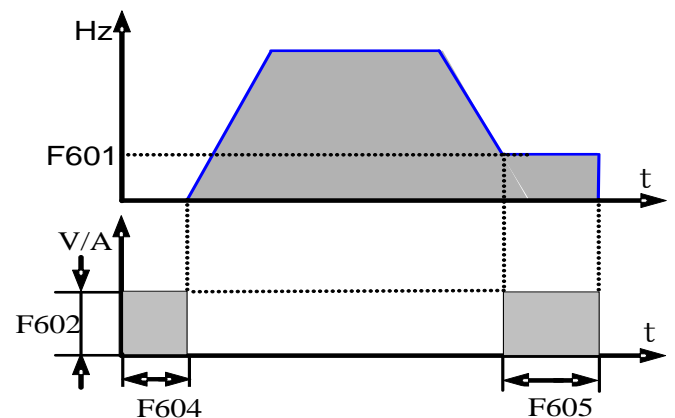

Figure 9-11 DC Braking

During braking before starting, if "stop" signal is given, inverter will stop by deceleration time.

When F600=2, DC braking during stopping is selected. After output frequency is lower than the initial frequency for DC braking (F601), DC braking will stop the motor immediately

During the process of braking during stopping, if "start" signal is given, DC braking will be finished and inverter will start.

If "stop" signal is given during the process of braking during stopping, inverter will have no response and DC braking during stopping still goes on.

Parameters related to "DC Braking": F601, F602, F603, F604, F605 and F606, interpreted as follows:

- F601: Initial frequency of DC-braking. DC braking will start to work as inverter's output frequency is lower than this value.
- F604: Braking duration before starting. The length of time for DC braking before inverter starts
- F605: Braking duration when stopping. The length of time for DC braking while inverter stops.



Note: during DC braking, because motor does not have self-cooling effect caused by rotating, it is in a condition of easy over-heating. Do not set DC braking voltage too high or set DC braking time to long.

DC braking, as shown in Figure 9-11.

F607 Selection of Stalling Adjusting Function	Setting range: 0: Invalid; 1: Valid 2: Reserved 3: Voltage current control 4: Voltage control 5: Current control	Mfr's value: 0
F608 Stalling Current Adjusting (%)	Setting range: 60~200	Mfr's value: 160
F609 Stalling Voltage Adjusting (%)	Setting range: 110~200	Mfr's value: 1 phase: 130 3 phase: 140
F610 Stalling Protection Judging Time (S)	Setting range: 0.1~3000.0	Mfr's value: 60.0

F607 is used to set selection of stalling adjusting function.

Voltage control: when motor stops quickly or load changes suddenly, DC bus voltage will be high. Voltage control function can adjust deceleration time and output frequency to avoid OE.

**When braking resistor or braking unit is used, do not use voltage control function otherwise, the deceleration time will be changed.**

Current control: when motor accelerates quickly or load changed suddenly, inverter may trip into OC. Current control function can adjust accel/decel time or decrease output frequency to control proper current value. It is only valid in VF control mode.

Note: (1) Voltage/current control is not suitable for lifting application.

(2) This function will change accel/decel time. Please use this function properly.

Initial value of stalling current adjusting is set by F608, when the present current is higher than rated current \*F608, stalling current adjusting function is valid.

During the process of deceleration, stalling current function is invalid.

During the process of acceleration, if output current is higher than initial value of stalling current adjusting and F607=1, then stalling adjusting function is valid. Inverter will not accelerate until the output current is lower than initial value of stalling current adjusting.

In case of stalling during stable speed running, the frequency will drop. If the current returns to normal during a stall condition the frequency will rise. Otherwise, the frequency will keep dropping to the minimum frequency and the protection OL1 will occur after it lasts for the time as set in F610.

Initial value of stalling voltage adjusting is set by F609, when the present voltage is higher than rated voltage \*F609, stalling voltage adjusting function is valid.

Stalling voltage adjusting is valid during the process of deceleration, including the deceleration process caused by stalling current.

Over-voltage means the DC bus voltage is too high and it is usually caused during deceleration. During the process of deceleration, DC bus voltage will increase because of energy feedback. When DC bus voltage is higher than the initial value of stalling voltage and F607=1, then stalling adjusting function is valid. Inverter will temporarily stop decelerating and keep output frequency constant, this stops energy being fed back into the inverter. Inverter will not decelerate until DC bus voltage is lower than the initial value of stalling voltage.

Stalling protection judging time is set by F610. When inverter starts stalling adjusting function and continues the period of time set by F610, inverter will stop running and OL1 protection occurs.

## 9-34 Function Parameters

F611	Dynamic Braking threshold	Setting range: 200~1000	Subject to inverter model
F612	Dynamic braking duty ratio (%)	Setting range: 0~100%	Mfr's value: 80

The starting voltage for the dynamic braking transistor is set by F611, which is in units of V. When DC bus voltage is higher than the setting value of this function, dynamic braking starts, braking unit starts working. After DC bus voltage is lower than the setting value, braking unit stops working.

Dynamic braking duty ratio is set by F612, the range is 0~100%. The value is higher, the braking effect is better, but the braking resistor will get hot.

F613 Flycatching	Setting range: 0: invalid 1: valid 2: valid at the first time	Mfr's value: 0
------------------	------------------------------------------------------------------------	----------------

When F613=0, the function of Flycatching is invalid.

When F613=1, the function of Flycatching is valid.

After inverter tracks motor speed and rotating direction, inverter will begin running according to the tracked frequency, to start the rotating motor smoothly. This function is suitable for the situation of auto-starting after repowered on, auto-starting after reset, auto-starting when running command valid but direction signal lost and auto-starting when running command invalid.

When F613=2, the function is valid at the first time after inverter is repower on.

Note: When F106=0, Flycatching function is invalid.

F614 Flycatching mode	Setting range: 0: Flycatching from frequency memory 1: Flycatching from max frequency 2: Flycatching from frequency memory and direction memory 3: Flycatching from max frequency and direction memory	Mfr's value: 0
-----------------------	--------------------------------------------------------------------------------------------------------------------------------------------------------------------------------------------------------------------	----------------

When F614 is set to 0 or 1, if memory frequency or max frequency is lower than 10.00Hz, inverter will track speed from 10.00Hz.

If inverter is powered down, inverter will remember valid target frequency. For the other situations (inverter has no output before stop), inverter will remember instant frequency before it stops.

This parameter is used for starting and stopping a motor with high inertia. A motor with high inertia will take a long time to stop completely. By setting this parameter, the user does not need to wait for the motor to come to a complete stop before restarting the AC motor drive.

F615 Flycatching rate	Setting range: 1~100	Mfr's value: 20
-----------------------	----------------------	-----------------

It is used to select the rotation velocity Flycatching when the rotation tracking restart mode is adopted. The larger the parameter is, the faster the Flycatching is. If this parameter is too large, its likely to result in unreliable tracking.

F619 Flycatching fault timeout period	Setting range: 0.0~3000.0S	Mfr's value: 60.0s
---------------------------------------	----------------------------	-----------------------

When F619=0, the function is not valid. When F619≠0, the function is valid. When Flycatching time is longer than the setting value of F619, it will trip into FL.

F627 Current limiting when Flycatching	50-200	100
----------------------------------------	--------	-----

This function code is used to limit the searching current and output current when Flycatching.

F622 Dynamic braking mode	Setting range: 0: Fixed duty ratio 1: Auto duty ratio	Mfr's value: 1
---------------------------	-------------------------------------------------------------	----------------

When F622=0, fixed duty ratio is valid. When bus-line voltage reaches energy consumption brake point set by F611, braking module will start dynamic braking according to F612.

When F622=1, auto duty ratio is valid. When bus-line voltage reaches dynamic braking threshold set by F611, braking module will start dynamic braking according to duty ratio which is adjusted by the bus-line voltage. The higher bus-line voltage is, the greater duty ratio is, and the better braking effect is. The braking resistor will get hotter.

F631 VDC adjustment selection	0: invalid 1: valid 2: reserved	Subject to inverter model
F632 Target voltage of VDC adjustor (V)	Setting range: 200~800	

When F631=1, VDC adjustment function is valid. During motor running process, the PN bus voltage will rise suddenly because of load mutation, over-voltage protection will occur. VDC adjustment is used to control voltage steady by adjusting output frequency or reducing braking torque.

If the DC bus voltage is higher than the setting value of F632, VDC adjustor will automatically adjust the bus voltage same as the value of F632.

F650 High-frequency performance	Setting range: 0: Invalid 1: Terminal enabled 2: Enabled mode 1 3: Enabled mode 2	Mfr's value: 2
F651 Switchover frequency 1	Setting range: F652-150.00	Mfr's value: 100.0
F652 Switchover frequency 2	Setting range: 0-F651	Mfr's value: 95.00

F650 is valid in vector control mode.

**Enabled mode 1:** when frequency is higher than F651, inverter will carry on optimized calculation for high-frequency performance. When frequency is lower than F652, the calculation will be stopped.

**Enabled mode 2:** when frequency is higher than F651, inverter will carry on optimized calculation until inverter stops.

**Terminal enabled:** when function of DIX terminal is set to 48, if DIX terminal is valid, inverter will carry on optimized calculation.

## 9.7 Malfunction and Protection

F700 Selection of terminal free stop mode	Setting range: 0: free stop immediately; 1: delayed free stop	Mfr's value: 0
F701 Delay time for free stop and programmable terminal action	Setting range: 0.0~60.0	Mfr's value: 0.0

“Selection of free stop mode” can be used only for the mode of “free stop” controlled by the terminal. The related parameters setting is F201=1, 2, 4 and F209=1.

When “free stop immediately” is selected, delay time (F701) will be invalid and inverter will free stop immediately.

“Delayed free stop” means that upon receiving “free stop” signal, the inverter will execute “free stop” command after waiting some time instead of stopping immediately. Delay time is set by F701.

F702 Fan control mode	0: controlled by temperature 1: Running when inverter is powered on. 2: controlled by running status	Mfr's value: 2
-----------------------	------------------------------------------------------------------------------------------------------------	----------------

When F702=0, fan will run if the heat sink temperature is up to setting temperature.

When F702=2, fan will run when inverter begins running. When inverter stops, fan won't stop until the heat sink temperature is lower than setting temperature.

F704 Inverter Overloading pre-alarm Coefficient (%)	Setting range: 50~100	Mfr's value: 80
F705 Motor Overloading pre-alarm Coefficient (%)	Setting range: 50~100	Mfr's value: 80
F706 Inverter Overloading Coefficient (%)	Setting range: 120~190	Mfr's value: 150
F707 Motor Overloading Coefficient (%)	Setting range: 20~100	Mfr's value: 100

Inverter overloading coefficient: the ratio of overload-protection current and rated current, whose value shall be subject to actual load.

Motor overloading coefficient (F707): when inverter drives lower power motor, set the value of F707 by below formula in order to protect motor

$$\text{Motor Overloading Coefficient} = \frac{\text{Rated motor power}}{\text{Rated inverter power}} \times 100\%$$

Set F707 according to actual situation. The lower the setting value of F707 is, the faster the overload protection speed. Please refer to Figure 9-12.

For example: 7.5kW inverter drives 5.5kW motor,  $F707=5.5/7.5 \times 100\% \approx 70\%$ . When the actual current of motor reaches 140% of inverter rated current, inverter overload protection will display after 1 minute.

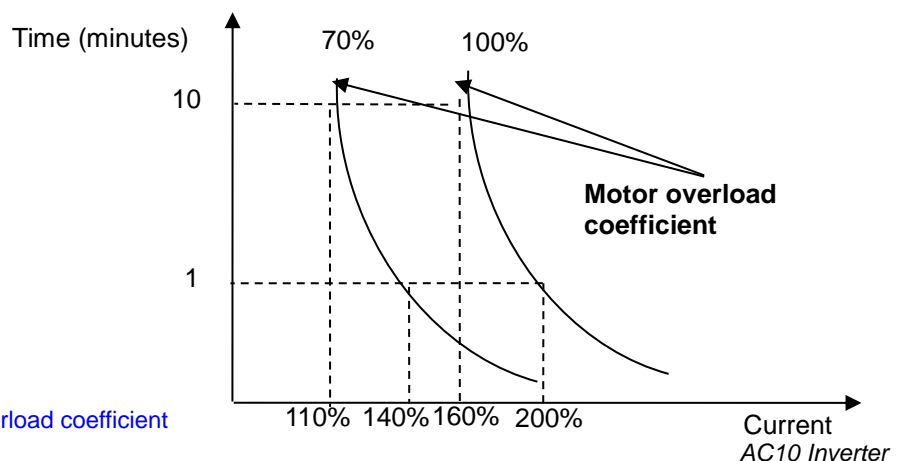

Figure 9-12 Motor overload coefficient

When the output frequency is lower than 10Hz, the heat dissipation effect of common motor will be worse. So when running frequency is lower than 10Hz, the threshold of motor overload value will be reduced. Please refer to Figure 9-13 (F707=100%):

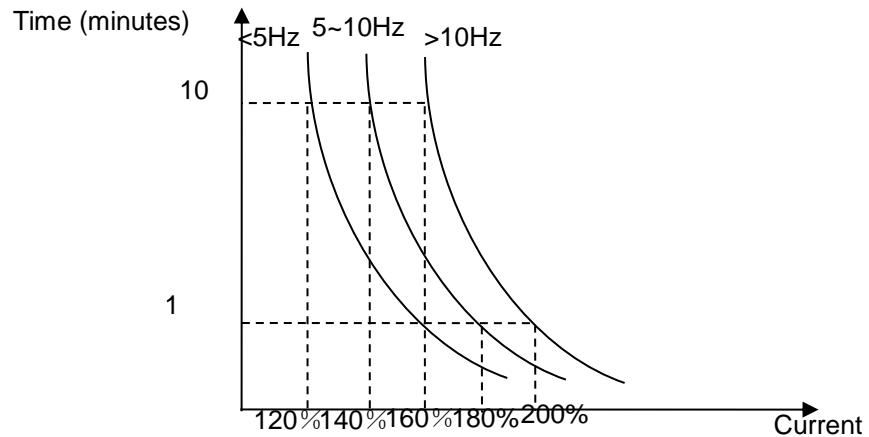

Figure 9-13 Motor overload protection value

F708	Record of The Latest Malfunction Type	Setting range: 2: over current (OC) 3: over voltage (OE) 4: input phase loss (PF1) 5: inverter overload (OL1) 6: under voltage (LU) 7: overheat (OH) 8: motor overload (OL2) 11: external malfunction (ESP) 12: Current fault before running (Err3) 13: studying parameters without motor (Err2)	
F709	Record of Malfunction Type for Last but One		
F710	Record of Malfunction Type for Last but Two		15: current sampling fault (Err4) 16: over current 1 (OC1) 17: output phase loss (PF0) 18: aerr analog disconnected 23: PID parameters are set wrong (Err5) 45: communication timeout (CE) 46: Flycatching fault (FL) 46: Flycatching fault (FL) 49: Watchdog fault (Err6)
F711	Fault Frequency of The Latest Malfunction		
F712	Fault Current of The Latest Malfunction		
F713	Fault PN Voltage of The Latest Malfunction		
F714	Fault Frequency of Last Malfunction but One		

## 9-38 Function Parameters

F715	Fault Current of Last Malfunction but One		
F716	Fault PN Voltage of Last Malfunction but One		
F717	Fault Frequency of Last Malfunction but Two		
F718	Fault Current of Last Malfunction but Two		
F719	Fault PN Voltage of Last Malfunction but Two		
F720	Record of overcurrent protection fault times		
F721	Record of overvoltage protection fault times		
F722	Record of overheat protection fault times		
F723	Record of overload protection fault times		
F724	Input phase loss	Setting range: 0: invalid; 1: valid	Mfr's value: 1
F726	Overheat	Setting range: 0: invalid; 1: valid	Mfr's value: 1
F727	Output phase loss	Setting range: 0: invalid; 1: valid	Mfr's value: 0
F728	Input phase loss filtering constant (S)	Setting range: 0.1~60.0	Mfr's value: 0.5
F730	Overheat protection filtering constant (S)	Setting range: 0.1~60.0	Mfr's value: 5.0
F732	Voltage threshold of under-voltage protection (V)	Setting range: 0~450	Subject to inverter model

“Under-voltage” refers to too low voltage at AC input side.

“Input phase loss” refers to phase loss of three-phase power supply, 5.5 kW and below inverters have not got this function.

“Output phase loss” refers to phase loss of inverter three-phase wirings or motor wirings.

·“phase loss” signal filtering constant is used for the purpose of eliminating disturbance to avoid mis-protection. The greater the set value is, the longer the filtering time constant is and the better for the filtering effect.

F737 Over-current 1 protection	Setting range: 0:Invalid 1: Valid	Mfr's value: 1
F738 Over-current 1 protection coefficient	Setting range: 0.50~3.00	Mfr's value: 2.50
F739 Over-current 1 protection record		

F738= OC 1 value/inverter rated current.

In running status, F738 is not allowed to modify. When over-current occurs, OC1 is displayed

F741 Analog disconnected protection	Setting range: 0: Invalid 1: Stop and AErr displays. 2: Stop and AErr is not displayed. 3: Inverter runs at the min frequency. 4: Reserved.	Mfr's value: 0
F742 Threshold of analog disconnected protection (%)	Setting range: 1~100	Mfr's value: 50

When the values of F400 and F406 are lower than 0.01V, analog disconnected protection is invalid.

When F741 is set to 1, 2 or 3, the values of F400 and F406 should be set to 1V-2V, to avoid the error protection by interference.

Analog disconnected protection voltage=analog channel input lower limit \* F742. Take the AI1 channel for the example, if F400=1.00, F742=50, then disconnection protection will occur when the AI1 channel voltage is lower than 0.5V.

F745 Threshold of pre-alarm overheat (%)	Setting range: 0~100	Mfr's value: 80
F747 Carrier frequency auto-adjusting	Setting range: 0: Invalid 1: Valid	Mfr's value: 1

When the temperature of the heatsink reaches the value of 95°C X F745 and multi-function output terminal is set to 16 (refer to F300~F302), it indicates inverter is in the status of overheat.

When F747=1, the temperature of the heatsink reaches 86°C, inverter carrier frequency will adjust automatically, to decrease the temperature of inverter. This function can avoid overheat malfunction.

When F159=1, random carrier frequency is selected, F747 is invalid.

F754 Zero-current threshold (%)	Setting range: 0~200	Mfr's value: 5
F755 Duration time of zero-current (S)	Setting range: 0~60	Mfr's value: 0.5

When the output current has fallen to zero-current threshold, and after the duration time of zero-current, ON signal is output.

## 9.8 Motor Parameters

F800	Motor's parameters tuning	Setting range: 0: Invalid; 1: Rotating tuning; 2: stationary tuning	Mfr's value: 0
F801	Rated power (kW)	Setting range: 0.75~1000	
F802	Rated voltage (V)	Setting range: 1~440	
F803	Rated current (A)	Setting range: 0.1~6500	
F804	Number of motor poles	Setting range: 2~100	4
F805	Rated rotary speed (rpm/min)	Setting range: 1~30000	
F810	Motor rated frequency (Hz)	Setting range: 1.0~650.0	50.00

Set the parameters in accordance with those indicated on the nameplate of the motor.

Good control performance of vector control requires accurate parameters of the motor. Accurate parameter tuning requires correct setting of rated parameters of the motor.

In order to get excellent control performance, configure the motor in accordance with adaptable motor of the inverter. In the case of too large difference between the actual power of the motor and that of adaptable motor for inverter, the inverter's control performance will decrease remarkably.

**F800=0**, parameter tuning is invalid. But it is still necessary to set the parameters F801~F803, F805 and F810 correctly according to those indicated on the nameplate of the motor.

After being powered on, it will use default parameters of the motor (see the values of F806-F809) according to the motor power set in F801. This value is only a reference value in view of Y series 4-pole asynchronous motor.

**F800=1**, rotating tuning.

In order to ensure dynamic control performance of the inverter, select "rotating tuning" after ensuring that the motor is disconnected from the load. Set F801-805 and F810 correctly prior to running testing.

Operation process of rotating tuning: Press the "I" key on the keypad to display "TEST", and it will tune the motor's parameter in two stages. After that, the motor will accelerate according to acceleration time set at F114 and maintain it for a certain period. The motor will then decelerate to 0 according to the time set at F115. After auto-checking is completed, relevant parameters of the motor will be stored in function codes F806~F809, and F800 will turn to 0 automatically.

**F800=2**, stationary tuning.

It is useful in some cases where it is impossible to disconnect the motor from the load.

Press the "I" key, and the inverter will display "TEST", and it will tune the motor's parameter in two stages. The motor's stator resistance, rotor resistance and leakage inductance will be stored in F806-F809 automatically (the motor's mutual inductance uses default value generated according to the power), and F800 will turn to 0 automatically. The user may also calculate and input the motor's mutual inductance value manually according to actual conditions of the motor. With regard to calculation formula and method, contact Parker for consultation.



When tuning the motor's parameter, motor is not running but it is powered on. Do not touch motor during this process.

\*Note:

1. No matter which tuning method of the motor parameters is adopted, set the information of the motor (F801-F805) correctly according to the nameplate of the motor. If the operator is quite familiar with the motor, the operator may input all the parameters (F806-F809) of the motor manually.

2. Parameter F804 can only be checked, not modified.



**3.** Incorrect motor parameters may result in unstable running of the motor or even failure of normal running. Correct tuning of the parameters is a requirement of vector control performance.

Each time when F801 rated power of the motor is changed, the parameters of the motor (F806-F809) will be refreshed to default settings automatically. Therefore, be careful while amending this parameter.

The motor's parameters may change when the motor heats up after running for a long time. If the load can be disconnected, we recommend auto-checking before each running.

F810 is motor rated frequency.

When F104=3, and F810=60.00, F802 will change to 460V automatically, F805 will change to 1800 automatically.

When F104=3, and F810=50.00, F802 will change to 380V automatically, F805 will change to 1460 automatically.

When F810 is set to the other values, F802 and F805 will not change automatically.

F802 and F805 can be set manually.

F806	Stator resistance	Setting range: 0.001~65.00Ω	
F807	Rotor resistance	Setting range: 0.001~65.00Ω	
F808	Leakage inductance	Setting range: 0.01~650.0mH	
F809	Mutual inductance	Setting range: 0.1~6500mH	

The set values of F806~F809 will be updated automatically after normal completion of parameter tuning of the motor.

The inverter will restore the parameter values of F806~F809 automatically to default standard parameters of the motor each time after changing F801 rated power of the motor;

If it is impossible to measure the motor in situ, input the parameters manually by referring to the known parameters of a similar motor.

Take a 3.7kW inverter for the example: all data are 3.7kW, 380V, 8.8A, 1440rpm/min, 50Hz, and the load is disconnected. When F800=1, the operation steps are as following:

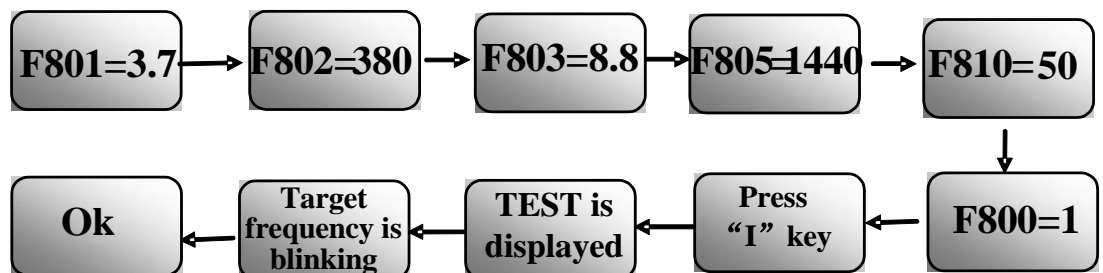

## 9-42 Function Parameters

F812	Pre-exciting time	Setting range: 0.000~30.00S	0.30S
F813	Rotary speed loop KP1	Setting range: 0.01~20.00	Subject to inverter model
F814	Rotary speed loop KI1	Setting range: 0.01~2.00	Subject to inverter model
F815	Rotary speed loop KP2	Setting range: 0.01~20.00	Subject to inverter model
F816	Rotary speed loop KI2	Setting range: 0.01~2.00	Subject to inverter model
F817	PID switching frequency 1	Setting range: 0~F111	5.00
F818	PID switching frequency 2	Setting range: F817~F111	50.00

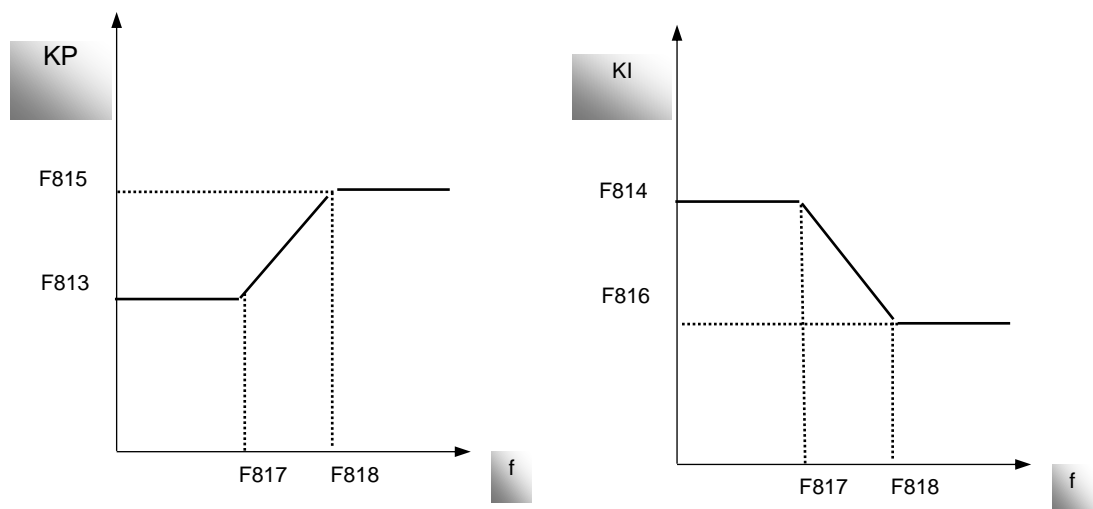

Figure 9-14 PID parameter

Dynamic response of vector control speed can be adjusted through adjusting gains of speed loop. Increasing KP and KI can speed up dynamic response of speed loop. However, if proportional gain or integral gain is too large, it may give rise to oscillation.

Recommended adjusting procedures:

Make fine adjustment of the value starting from the manufacturer value if the manufacturer setting value cannot meet the needs of practical application. Be cautious that amplitude of adjustment each time should not be too large.

In the event of weak loading capacity or slow rising of rotary speed, increase the value of KP first under the precondition of ensuring no oscillation. If it is stable, increase the value of KI properly to speed up response.

In the event of oscillation of current or rotary speed, decrease KP and KI properly.

In conditions of uncertainty, decrease KP at first, if there is no effect, increase KP. Then adjust KI.

Note: Improper setting of KP and KI may result in violent oscillation of the system, or even failure of normal operation. Set them carefully.

## 9.9 Communication Parameter

F900 Communication Address	1~255: single inverter address 0: broadcast address	1
F901 Communication Mode	1: ASCII 2: RTU	1
F903 Parity Check	0: Invalid 1: Odd 2: Even	0
F904 Baud Rate(bps)	Setting range: 0: 1200; 1: 2400; 2: 4800; 3: 9600; 4: 19200 5: 38400 6: 57600	3

F904=9600 is recommended for baud rate.

F905 Communication timeout period	Setting range: 0~3000	Mfr's value: 0
-----------------------------------	-----------------------	----------------

When F905 is set to 0.0, the function is invalid. When  $F905 \neq 0.0$ , if the inverter has not received effective command from PC/PLC during the time set by F905, inverter will trip into CE.

Communication parameters refer Chapter 13 The Default Applications.

## 9.10 PID Parameters

Internal PID adjusting control is used for simple close-loop system with convenient operation.

FA01 PID adjusting target given source	Setting range: 0: FA04 1: AI1 2: AI2	Mfr's value: 0
----------------------------------------	-----------------------------------------------	----------------

When FA01=0, PID reference target is given by FA04 or MODBUS.

When FA01=1, PID reference target is given by external analog AI1.

When FA01=2, PID reference target is given by external analog AI2.

FA02 PID feedback signal given source	Setting range: 1: AI1 2: AI2	Mfr's value: 1
---------------------------------------	------------------------------------	----------------

When FA02=1, PID reference feedback signal is given by external analog AI1.

When FA02=2, PID reference feedback signal is given by external analog AI2.

FA03 Max limit of PID adjusting (%)	FA04~100.0	Mfr's value: 100.0
FA04 Digital setting value of PID adjusting (%)	FA05~FA03	Mfr's value: 50.0
FA05 Min limit of PID adjusting (%)	0.1~FA04	Mfr's value: 0.0

When FA01=0, the value set by FA04 is digital setting reference value of PID adjusting.

## 9-44 Function Parameters

FA06 PID polarity	0: Positive feedback 1: Negative feedback	Mfr's value: 1
-------------------	----------------------------------------------	----------------

When FA06=0, the higher feedback value is, the higher the motor speed is. This is positive feedback.

When FA06=1, the lower the feedback value is, the higher the motor speed is. This is negative feedback.

FA07 Sleep function selection	Setting range: 0: Valid 1: Invalid	Mfr's value: 1
-------------------------------	------------------------------------------	----------------

When FA07=0, if inverter runs at the min frequency FA09 for a period time set by FA10, inverter will stop.

When FA07=1, the sleep function is invalid.

FA09 Min frequency of PID adjusting (Hz)	Setting range: F112~F111	Mfr's value: 5.00
------------------------------------------	-----------------------------	-------------------

The min frequency is set by FA09 when PID adjusting is valid.

FA10 Sleep delay time (S)	Setting range: 0~500.0	Mfr's value: 15.0
FA11 Wake delay time (S)	Setting range: 0.0~3000	Mfr's value: 3.0
FA18 Whether PID adjusting target is changed	0: Invalid 1: Valid	Mfr's value: 1

When FA18=0, PID adjusting target cannot be changed.

FA19 Proportion Gain P	Setting range: 0.00~10.00	Mfr's value: 0.3
FA20 Integration time I (S)	Setting range: 0.1~100.0	Mfr's value: 0.3
FA21 Differential time D (S)	Setting range: 0.0~10.0	Mfr's value: 0.0
FA22 PID sampling period (S)	Setting range: 0.1~10.0	Mfr's value: 0.1

Increasing proportion gain, decreasing integration time and increasing differential time can increase the dynamic response of PID closed-loop system. But if P is too high, I is too low or D is too high, system will not be steady.

PID adjusting period is set by FA22. It affects PID adjusting speed.

The following is PID adjusting arithmetic.

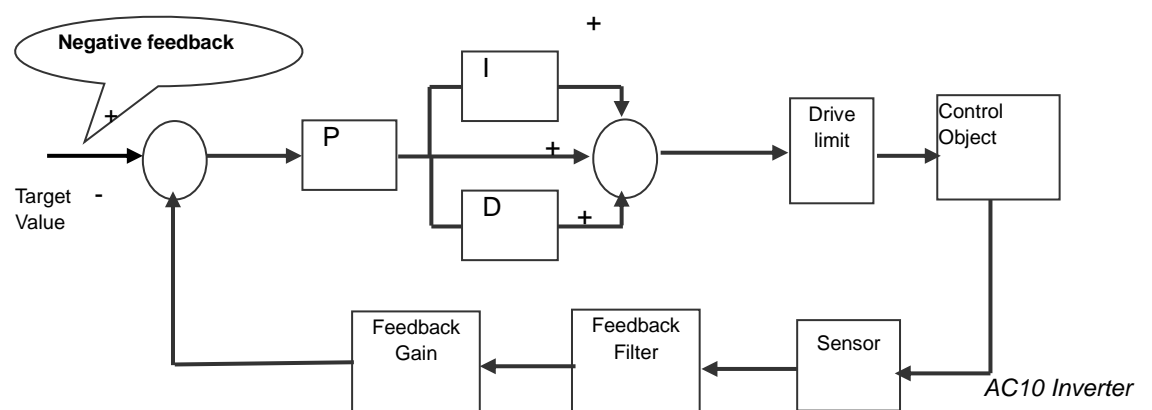

FA29 PID dead time (%)	0.0~10.0	Mfr's value: 2.0
------------------------	----------	------------------

FA29, PID dead time has two functions. First, setting dead time can restrain PID adjustor oscillation. The greater this value is, the lighter PID adjustor oscillation is. But if the value of FA29 is too high, PID adjusting precision will decrease. For example: when FA29=2.0 and FA04=70, PID adjusting will not be valid during the feedback value from 68 to 72.

FA58 Fire pressure given value (%)	Setting range: 0.0~100.0	Mfr's value: 80.0
------------------------------------	-----------------------------	-------------------

FA58 is also called second pressure, when the fire control terminal is valid, pressure target value will switch into second pressure value.

FA59 Emergency fire mode	Setting range: 0: Invalid 1: Emergency fire mode 1 2: Emergency fire mode 2	Mfr's value: 0
--------------------------	--------------------------------------------------------------------------------------	----------------

When emergency fire mode is valid and emergency fire terminal is valid, inverter will be forbidden operating and protecting (When OC and OE protection occur, inverter will reset automatically and start running) and inverter will run at the frequency of FA60 or target frequency until inverter is broken.

Emergency fire mode 1: when the terminal is valid, inverter will run at target frequency.

Emergency fire mode 2: when the terminal is valid, inverter will run at the frequency of FA60.

FA60 Running frequency of emergency fire	Setting range: F112~F111	Mfr's value: 50.0
------------------------------------------	-----------------------------	-------------------

When the emergency fire mode 2 is valid and the fire terminal is valid, inverter will run at the frequency set by FA60.

FA62 when emergency fire control terminal is invalid	Setting range: 0: inverter can not be stopped manually 1: inverter can be stopped manually	Mfr's value: 0
------------------------------------------------------	--------------------------------------------------------------------------------------------------	----------------

•FA62=0, when emergency fire control terminal (DIX=33) is invalid, before repower on inverter, or reset inverter, inverter can not be stopped manually.

•FA62=1, when emergency fire control terminal (DIX=33) is invalid, after quitting from emergency fire mode, inverter can be stopped manually

## 9.11 Torque control parameters

FC00 Speed/torque control selection	0: Speed control 1: Torque control 2: Terminal switchover	0
-------------------------------------	-----------------------------------------------------------------	---

**0:** speed control. Inverter will run by setting frequency, and output torque will automatically match with the torque of load, and output torque is limited by max torque (set by manufacture.)

**1:** Torque control. Inverter will run by setting torque, and output speed will automatically match with the speed of load, and output speed is limited by max speed (set by FC23 and FC25). Please set the proper torque and speed limits.

**2:** Terminal switchover. User can set DIX terminal as torque/speed switchover terminal to realize switchover between torque and speed. When the terminal is valid, torque control is valid. When the terminal is invalid, speed control is valid.

## 9-46 Function Parameters

FC01	Delay time of torque/speed control switchover (S)	0.0~1.0	0.1
------	---------------------------------------------------	---------	-----

This function is valid with terminal switchover.

FC02	Torque accel/decel time (S)	0.1~100.0	1
------	-----------------------------	-----------	---

The time is for inverter to run from 0% to 100% of motor rated torque.

FC06	Torque reference source	0: Digital given (FC09) 1: Analog input AI1 2: Analog input AI2	0
FC07	Torque reference coefficient (analogue input)	0~3.000	3.000
FC09	Torque reference command value (%)	0~300.0	100.0

FC07: when input given torque reaches max value, FC07 is the ratio of inverter output torque and motor rated torque. For example, if FC06=1, F402=10.00, FC07=3.00, when AI1 channel output 10V, the output torque of inverter is 3 times of motor rated torque.

FC14	Offset torque reference source	0: Digital given (FC17) 1: Analog input AI1 2: Analog input AI2	0
FC15	Offset torque coefficient	0~0.500	0.500
FC16	Offset torque cut-off frequency (%)	0~100.0	10.0
FC17	Offset torque command value (%)	0~50.0	10.00

Offset torque is used to output larger start torque which equals to setting torque and offset torque when motor drives big inertia load. When actual speed is lower than the setting frequency by FC16, offset torque is given by FC14. When actual speed is higher than the setting frequency by FC16, offset torque is 0.

When FC14≠0, and offset torque reaches max value, FC15 is the ratio of offset torque and motor rated torque. For example: if FC14=1, F402=10.00 and FC15=0.500, when AI1 channel outputs 10V, offset torque is 50% of motor rated torque.

FC22	Forward speed limited channel	0: Digital given (FC23) 1: Analog input AI1 2: Analog input AI2	0
FC23	Forward speed limited (%)	0~100.0	10.0
FC24	Reverse speed limited channel	0: Digital given (FC25) 1: Analog input AI1 2: Analog input AI2	0
FC25	Reverse speed limited (%)	0~100.0	10.00

Speed limited FC23/FC25: if given speed reaches max value, they are used to set percent of inverter output frequency and max frequency F111.

FC28	Driving torque limit channel	0: Digital given (FC30) 1: Analog input AI1 2: Analog input AI2	0
------	------------------------------	-----------------------------------------------------------------------	---

## Function Parameters 9-47

FC29	Driving torque limit coefficient	0~3.000	3.000
FC30	Driving torque limit (%)	0~300.0	200.0
FC31	Re-generating torque limit channel	0: Digital given (FC35) 1: Analog input AI1 2: Analog input AI2	0
FC34	Re-generating torque limit coefficient	0~3.000	3.000
FC35	Re-generating torque limit (%)	0~300.0	200.00

When motor is in the driving status, output torque limit channel is set by FC28, and limit torque is set by FC29.

When motor is in the re-generating status, re-generating torque limit channel is set by FC31, and limit torque is set by FC34.





# 10-1 Troubleshooting

## Chapter 10 Troubleshooting

When the inverter is tripped check what the cause is and rectify as required.

Take counter measures by referring to this manual in case of any malfunctions on inverter. Should it still be unsolved, contact the manufacturer. Never attempt any repairs without due authorization.

Table 10-1 Inverter's Common Cases of Malfunctions

Fault	Description	Causes	Possible Solution
O.C.	Overcurrent		* prolong acceleration time
OC1	Overcurrent 1	* too short acceleration time * short circuit at output side * locked rotor with motor * parameter tuning is not correct	* is motor cable broken * check if motor overloads * reduce VVVF compensation value * measure parameter correctly
O.L1	Inverter Overload	* load too heavy	* reduce load; *check drive ratio * increase inverter's capacity
O.L2	Motor Overload	* load too heavy	* reduce load; *check drive ratio * increase motor's capacity
O.E.	DC Over-Voltage	* supply voltage too high * load inertia too big * deceleration time too short * motor inertia rise again * parameter of speed loop PID is set abnormally	* check if rated voltage is input * add braking resistance(optional) * increase deceleration time * set the parameter of rotary speed loop PID correctly
P.F1.	Input Phase Loss	* phase loss with input power	* check if power input is normal * check if parameter setting is correct
PF0	Output Phase Loss	* Motor is broken * Motor wire is loose. * Inverter is broken	* check if wire of motor is loose * check if motor is broken
L.U.	Under-Voltage Protection	* Low voltage on the input side	* check if supply voltage is normal * check if parameter setting is correct
O.H.	Heatsink Overheat	* environment temperature too high * poor ventilation * fan damaged * Carrier wave frequency or compensation curve is too high	* improve ventilation * clean air inlet and outlet and radiator * install as required * change fan * Decrease carrier wave frequency or compensation curve
AErr	Line Disconnected	* Analog signal line disconnected * Signal source is broken	* Change the signal line * Change the signal source
Err1	Password is Wrong	* When password function is valid, password is set wrong	* Set password correctly
Err2	Parameters Tuning Wrong	* incorrect motor parameters entered	* Connect motor correctly
Err3	Current Malfunction Before Running	* Current alarm signal exists before running	* Check if control board is properly connected to power board * Contact Parker
Err4	Current Zero Excursion Malfunction	* Flat cable is loosened * Current detector is broken	* Check the flat cable * Contact Parker
Err5	PID Parameters are set Wrong,	* PID parameters are set wrong. *	* Set the parameters correctly
CE	Communication Timeout	* Communication fault	* PC/PLC does not send command at fixed

Fault	Description	Causes	Possible Solution
			time * Check whether the communication line is connected reliably
FL	Flycatching Fault	Flycatching failure	* Track again * Contact manufacturer

- No P.F1 protection for single-phase and three-phase under 5.5kW.

Table 10-2 Motor Malfunction and Counter Measures

Malfunction	Items to Be Checked	Counter Measures
Motor not Running	Wiring correct? Setting correct? Too big with load? Motor is damaged? Malfunction protection occurs?	Get connected with power Check wiring Checking malfunction Reduce load Check against Table 10-1
Wrong Direction of Motor Running	U, V, W wiring correct? Parameters setting correct?	Correct wiring Set the parameters correctly
Motor Turning but Speed Change not Possible	Wiring correct for lines with given frequency? Correct setting of running mode? Too big with load?	Correct wiring To correct setting; Reduce load
Motor Speed Too High or Too Low	Motor's rated value correct? Drive ratio correct? Inverter parameters are set in-corrected? Check if inverter output voltage is abnormal?	Check motor nameplate data Check the setting of drive ratio Check parameters setting Check VVVF Characteristic value
Motor Running Unstable	Too big load? Too big with load change? Phase loss? Motor malfunction.	Reduce load; reduce load change, increase capacity Correct wiring
Power Trip	Wiring current is too high?	Check input wiring Selecting matching air switch Reduce load Check inverter malfunction

# 11-1 Technical Specifications

## Chapter 11 Technical Specifications

### 11.1 Selection of Braking Resistance

Inverter Models	Applicable Motor Power (kW)	Applicable Braking Resistance	
10G-11-0015	0.2	150W/60Ω	
10G-11-0025	0.37		
10G-11-0035	0.55		
10G-11-0045	0.75		
10G-12-0050	1.1		
10G-12-0070	1.5		
10G-12-0100	2.2		
10G-31-0015	0.2		
10G-31-0025	0.37		
10G-31-0035	0.55		
10G-31-0045	0.75		
10G-32-0050	1.1		
10G-32-0070	1.5		
10G-32-0100	2.2		
10G-41-0006	0.2		80W/500Ω
10G-41-0010	0.37		
10G-41-0015	0.55		
10G-42-0020	0.75	80W/200Ω	
10G-42-0030	1.1	80W/150Ω	
10G-42-0040	1.5		
10G-42-0065	2.2	150W/150Ω	
10G-43-0080	3.0		
10G-43-0090	4.0		
10G-43-0120	5.5	250W/120Ω	
10G-44-0170	7.5	500W/120Ω	
10G-44-0230	11	1kW/90Ω	
10G-45-0320	15	1.5kW/80Ω	
10G-45-0380	18.5	1.5kW/35Ω	
10G-45-0440	22	1.5kW/35Ω	

Note: in the occasion of large inertia load, if the braking resistor heat is excessive, use a larger power of resistor than the recommended resistor.



## Chapter 12 Modbus Communication

### 12.1 General

Modbus is a serial and asynchronous communication protocol. Modbus protocol is a general language applied to PLC and other controlling units. This protocol has defined an information structure which can be identified and used by a controlling unit regardless of whatever network they are transmitted.

You can read reference books or ask for the details of MODBUS from manufactures.

Modbus protocol does not require a special interface while a typical physical interface is RS485.

### 12.2 Modbus Protocol

#### 12.2.1 Transmission mode

##### Format

##### ASCII mode

Start	Address	Function	Data				LRC check		End	
<b>(0X3A)</b>	Inverter Address	Function Code	Data Length	Data 1	...	Data N	High-order byte of LRC	Low-order byte of LRC	Return (0X0D)	Line Feed (0X0A)

##### RTU mode

Start	Address	Function	Data	CRC check		End
<b>T1-T2-T3-T4</b>	Inverter Address	Function Code	N data	Low-order byte of CRC	High-order byte of CRC	T1-T2-T3-T4

#### 12.2.2 ASCII Mode

In ASCII mode, one Byte (hexadecimal format) is expressed by two ASCII characters.

For example, 31H (hexadecimal data) includes two ASCII characters '3(33H)', '1(31H)'.

Common characters, ASCII characters are shown in the following table:

Characters	'0'	'1'	'2'	'3'	'4'	'5'	'6'	'7'
ASCII Code	30H	31H	32H	33H	34H	35H	36H	37H
Characters	'8'	'9'	'A'	'B'	'C'	'D'	'E'	'F'
ASCII Code	38H	39H	41H	42H	43H	44H	45H	46H

#### 12.2.3 RTU Mode

In RTU mode, one Byte is expressed by hexadecimal format. For example, 31H is delivered to data packet.

### 12.3 Baud rate

Setting range: 1200, 2400, 4800, 9600, 19200, 38400, 57600

# 12-2 Modbus Communication

## 12.4 Frame structure:

ASCII mode

Byte	Function
1	Start Bit (Low Level)
7	Data Bit
0/1	Parity Check Bit (None for this bit in case of no checking. Otherwise 1 bit)
1/2	Stop Bit (1 bit in case of checking, otherwise 2 bits)

RTU mode

Byte	Function
1	Start Bit (Low Level)
8	Data Bit
0/1	Parity Check Bit (None for this bit in case of no checking. Otherwise 1 bit)
1/2	Stop Bit (1 bit in case of checking, otherwise 2 bits)

## 12.5 Error Check

### 12.5.1 ASCII mode

Longitudinal Redundancy Check (LRC): It is performed on the ASCII message field contents excluding the 'colon' character that begins the message, and excluding the CRLF pair at the end of the message.

The LRC is calculated by adding together successive 8-bit bytes of the message, discarding any carries, and then two's complementing the result.

A procedure for generating an LRC is:

1. Add all bytes in the message, excluding the starting 'colon' and ending CRLF. Add them into an 8-bit field, so that carries will be discarded.
2. Subtract the final field value from FF hex (all 1's), to produce the ones-complement.
3. Add 1 to produce the twos-complement.

### 12.5.2 RTU Mode

Cyclical Redundancy Check (CRC): The CRC field is two bytes, containing a 16-bit binary value.

The CRC is started by first preloading a 16-bit register to all 1's. Then a process begins of applying successive 8-bit bytes of the message to the current contents of the register. Only the eight bits of data in each character are used for generating the CRC. Start and stop bits, and the parity bit, do not apply to the CRC.

A procedure for generating a CRC-16 is:

1. Load a 16-bit register with FFFF hex (all 1's). Call this the CRC register.
2. Exclusive OR the first 8-bit byte of the message with the high-order byte of the 16-bit CRC register, putting the result in the CRC register.
3. Shift the CRC register one bit to the right (toward the LSB), zero-filling the MSB. Extract and examine the LSB.
4. (If the LSB was 0): Repeat Step 3 (another shift).
- (If the LSB was 1): Exclusive OR the CRC register with the polynomial value A001 hex (1010 0000 0000 0001).
5. Repeat Steps 3 and 4 until 8 shifts have been performed. When this is done, a complete 8-bit byte will have been processed.

When the CRC is appended to the message, the low-order byte is appended first, followed by the high-order byte.

## 12.5.3 Protocol Converter

It is easy to turn a RTU command into an ASCII command followed by the lists:

1. Use the LRC replacing the CRC.
2. Transform each byte in RTU command into a corresponding two byte ASCII. For example: transform 0x03 into 0x30, 0x33 (ASCII code for 0 and ASCII code for 3).
3. Add a 'colon' ( : ) character (ASCII 3A hex) at the beginning of the message.
4. End with a 'carriage return – line feed' (CRLF) pair (ASCII 0D and 0A hex).

So we will introduce RTU Mode in followed part. If you use ASCII mode, you can use the up lists to convert.

## 2.6 Command Type & Format

The listing below shows the function codes.

Code	Name	Description
03	Read Holding Registers	Read the binary contents of holding registers in the slave. (Less than 10 registers once time )
06	Preset Single Register	Preset a value into holding register

### 12.6.1 Address and meaning

The part introduces inverter running, inverter status and related parameters setting.

Description of rules of function codes parameters address:

- i) Use the function code as parameter address

General Series:

High-order byte: 01~0A (hexadecimal)

Low-order byte: 00~50 (max range) (hexadecimal) Function code range of each partition is not the same. For the specific range refer to manual.

For example: parameter address of F114 is 010E (hexadecimal).

parameter address of F201 is 0201 (hexadecimal).

Note: in this situation, it allows to read six function codes and write only one function code.

Some function codes can only be checked but cannot be modified; some function codes can neither be checked nor be modified; some function codes cannot be modified in run state; some function codes cannot be modified both in stop and run state.

In case parameters of all function codes are changed, the effective range, unit and related instructions refer to user manual for related series of inverters. Otherwise, unexpected results may occur.

- ii) Use different parameters as parameter address

(The above address and parameters descriptions are in hexadecimal format, for example, the decimal digit 4096 is represented by hexadecimal 1000).

# 12-4 Modbus Communication

## 12.6.2 Running Status Parameters

Parameters Address	Parameter Description (read only)
1000	Output frequency
1001	Output voltage
1002	Output current
1003	Pole numbers/ control mode, high-order byte is pole numbers, low-order byte is control mode.
1004	Bus voltage
1005 ----AC10	Drive ratio/inverter status High-order byte is drive ratio, low-order byte is inverter status Inverter status: 0X00: Standby mode 0X01: Forward running 0X02: Reverse running 0X04: Over-current (OC) 0X05: DC over-current (OE) 0X06: Input Phase loss (PF1) 0X07: Frequency Over-load (OL1) 0X08: Under-voltage (LU) 0X09: Overheat (OH) 0X0A: Motor overload (OL2) 0X0B: Interference (Err) 0X0C: LL 0X0D: External Malfunction (ESP) 0X0E: Err1 0X0F: Err2 0X10: Err3 0X11: Err4 0X12: OC1 0X13:PF0 0X14: Analog disconnected protection (AErr) 0X19: PID parameters are set incorrectly (Err5) 0X2D: Communication timeout (CE) 0X2E: Flycatching fault (FL) 0X31: Watchdog fault (Err6)
1006	The percent of output torque
1007	Inverter radiator temperature
1008	PID given value
1009	PID feedback value



Reading parameter address	Function	Remarks
100A	Read integer power value	The integer power value is read by PC.
100B	DI terminal status	DI1~DI5—bit0~bit4
100C	Terminal output status	bit0-OUT1 bit2-fault relay
100D	AI1	0~4095 read input analog digital value
100E	AI2	0~4095 read input analog digital value
1010	Reserved	
1011	Reserved	
1012	Reserved	
1013	Present-stage speed value	Monitoring in which stage speed inverter is. 0000 Stage speed 1 0001 stage speed 2 0010 Stage speed 3 0011 Stage speed 4 0100 Stage speed 5 0101 Stage speed 6 0110 Stage speed 7 0111 Stage speed 8 1000 Stage speed 9 1001 Stage speed 10 1010 Stage speed 11 1011 Stage speed 12 1100 Stage speed 13 1101 Stage speed 14 1110 Stage speed 15 1111 None
1014	Reserved	
1015	AO1 (0~100.00)	Monitoring analog output percent
1017	Current speed	Monitoring current speed.
1018	Read accurate power value	Correct the power to 1 decimal place.

### 12.6.3 Control commands

Parameters Address	Parameters Description (write only)
2000	Command meaning: 0001: Forward running (no parameters) 0002: Reverse running (no parameters) 0003: Deceleration stop 0004: Free stop 0005: Forward jogging start 0006: Forward jogging stop 0007: Reserved 0008: Run (no directions) 0009: Fault reset 000A: Forward jogging stop 000B: Reverse jogging stop

## 12-6 Modbus Communication

2001	Lock parameters 0001: Relieve system locked (remote control locked) 0002: Lock remote control (any remote control commands are no valid before unlocking) 0003: RAM and eeprom are permitted to be written. 0004: Only RAM is permitted to be written, eeprom is prohibited being written.
------	--------------------------------------------------------------------------------------------------------------------------------------------------------------------------------------------------------------------------------------------------------------------------------------------------------

Writing parameter address	Function	Remarks
2002	AO1 output percent is set by PC/PLC. Setting range: 0~1000	F431=7 AO1 token output analog is controlled by PC/PLC.
2003	Reserved	
2004	Reserved	
2005	Multi-function output terminal DO1	1 means token output is valid. 0 means token output is invalid.
2006	Reserved	
2007	Reserved	

### 12.6.4 Illegal Response When Reading Parameters

Command Description	Function	Data
Slave parameters response	The highest-order byte changes into 1.	Command meaning: 0001: Illegal function code 0002: Illegal address 0003: Illegal data 0004: Slave fault <sup>note 2</sup>

Note 2: Illegal response 0004 appears below two cases:

Do not reset inverter when inverter is in the malfunction state.

Do not unlock inverter when inverter is in the locked state.

#### Additional Remarks

Expressions during communication process:

Parameter Values of Frequency=actual value X 100

Parameter Values of Time=actual value X 10

Parameter Values of Current=actual value X 100

Parameter Values of Voltage=actual value X 1

Parameter Values of Power (100A)=actual value X 1

Parameter Values of Power (1018)=actual value X 10

Parameter Values of Drive Ratio=actual value X 100

Parameter Values of Version No. =actual value X 100

Instruction: Parameter value is the value sent in the data package. Actual value is the actual value of inverter. After PC/PLC receives the parameter value, it will divide the corresponding coefficient to get the actual value.

NOTE: Take no account of radix point of the data in the data package when PC/PLC transmits command to inverter. The valid value is range from 0 to 65535.

## 12.7 Function Codes Related to Communication

Function Code	Function Definition	Setting Rang	Mfr's Value
F200	Source of start command	0: Keypad command; 1: Terminal command; 2: Keypad+ Terminal; 3: MODBUS; 4: Keypad+ Terminal+ MODBUS	4
F201	Source of stop command	0: Keypad command; 1: Terminal command; 2: Keypad+ Terminal; 3: MODBUS; 4: Keypad+ Terminal+ MODBUS	4
F203	Main frequency source X	0: Digital setting memory; 1: External analog AI1; 2: External analog AI2; 3: Reserved 4: Stage speed control; 5: No memory by digital setting; 6:Reserved; 7: Reserved; 8: Reserved; 9: PID adjusting; 10: MODBUS	0
F900	Inverter Address	1~255	1
F901	Modbus Mode Selection	1: ASCII mode 2: RTU mode	1
F903	Parity Check	0: Invalid 1: Odd 2: Even	0
F904	Baud Rate(bps)	0: 1200 1: 2400 2: 4800 3: 9600 4: 19200 5: 38400 6: 57600	3

Please set functions code related to communication consonant with the PLC/PC communication parameters, when inverter communicates with PLC/PC.

# 12-8 Modbus Communication

## 12.8 Physical Interface

### 12.8.1 Interface instruction

Communication interface of RS485 is located on the most left of control terminals, marked underneath with A+ and B-

### 12.8.2 Structure of Field Bus

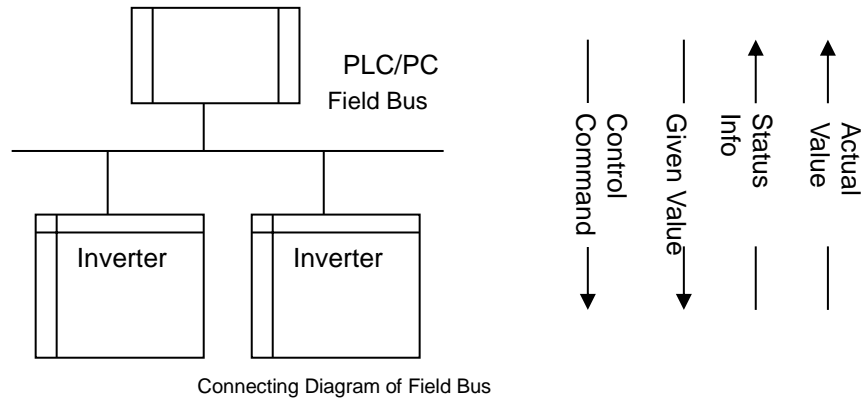

RS485 Half-duplex communication mode is adopted for AC10 series inverter. Daisy chain structure is adopted by 485 Bus-line. Do not use 'spur' lines or a star configuration. Reflect signals which are produced by spur lines or star configuration will interfere in 485 communications.

Note that for the same time in half-duplex connection; only one inverter can have communication with PC/PLC. Should two or more than two inverters upload data at the same time, then bus competition will occur, which will not only lead to communication failure, but higher current to certain elements as well.

### 12.9 Grounding and Terminal

Terminal resistance of  $120\ \Omega$  will be adopted for terminal of RS485 network, to diminish the reflection of signals. Terminal resistance shall not be used for intermediate network.

No direct grounding shall be allowed for any point of RS485 network. All the equipment in the network shall be well grounded via their own grounding terminal. Please note that grounding wires will not form closed loop in any case.

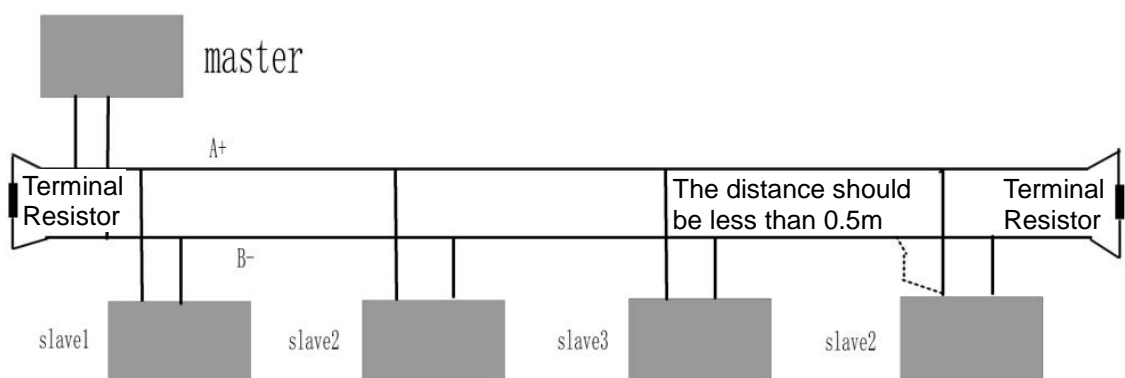

Check the drive capacity of PC/PLC and the distance between PC/PLC and inverter when wiring. Add a repeaters if drive capacity is not enough.



All wiring connections for installation shall have to be made when the inverter is disconnected from power supply.

## 12.9.1 Examples

**Eg1:** In RTU mode, change acc time (F114) to 10.0s in NO.01 inverter.

### Query

Address	Function	Register Address Hi	Register Address Lo	Preset Data Hi	Preset Data Lo	CRC Lo	CRC Hi
01	06	01	0E	00	64	E8	1E

**Function code F114      Value: 10.0S**

### Normal Response

Address	Function	Register Address Hi	Register Address Lo	Response Data Hi	Response Data Lo	CRC Lo	CRC Hi
01	06	01	0E	00	64	E8	1E

**Function code F114      Normal Response**

### Abnormal Response

Address	Function	Abnormal code	CRC Lo	CRC Hi
01	86	04	43	A3

**The max value of function code is 1.      Slave fault**

**Eg 2:** Read output frequency, output voltage, output current and current rotate speed from NO.2 inverter.

### Host Query

Address	Function	First Register Address Hi	First Register Address Lo	Register count Hi	Register count LO	CRC Lo	CRC Hi
02	03	10	00	00	04	40	FA

Communication Parameters Address 1000H

### Slave Response:

Address	Function	Byte Count	Data Hi	Data Lo	Data Hi	Data Lo	Data Hi	Data Lo	Data Hi	Data Lo	Crc Lo	Crc Hi
02	03	08	13	88	01	90	00	3C	02	00	82	F6

Output Frequency    Output Voltage    Output Current    Numbers of Pole Pairs    Control Mode

NO.2 Inverter's output frequency is 50.00Hz, output voltage is 380V, output current is 0.6A, numbers of pole pairs are 2 and control mode keypad control.

# 12-10 Modbus Communication

Eg 3: No.1 Inverter runs forwardly.

**Host Query:**

Address	Function	Register Hi	Register Lo	Write status Hi	Write status Lo	CRC Lo	CRC Hi
01	06	20	00	00	01	43	CA

Communication parameters address 2000H

Forward running

**Slave Normal Response:**

Address	Function	Register Hi	Register Lo	Write status Hi	Write status Lo	CRC Lo	CRC Hi
01	06	20	00	00	01	43	CA

Normal Response

**Slave Abnormal Response:**

Address	Function	Abnormal Code	CRC Lo	CRC Hi
01	86	01	83	A0

The max value of function code is 1. Illegal function code (assumption)

Eg4: Read the value of F113, F114 from NO.2 inverter

**Host Query:**

Address	Function	Register Address Hi	Register Address Lo	Register Count Hi	Register Count Lo	CRC Lo	CRC Hi
02	03	01	0D	00	02	54	07

Communication Parameter Address F10DH

Numbers of Read Registers

**Slave Normal Response:**

Address	Function	Byte count	The first parameters status Hi	The first parameters status Lo	The second parameters status Hi	The second parameters status Lo	CRC Lo	CRC Hi
02	03	04	03	E8	00	78	49	61

The actual value is 10.00.

The actual value is 12.00.

**Slave Abnormal Response:**

Address	Function Code	Abnormal Code	CRC Lo	CRC Hi
02	83	08	B0	F6

The max value of function code is 1.

Parity check fault

## Chapter 13 The Default Applications

The drive is supplied with 5 Applications, Application 0 to Application 5. Please refer to following:

Application 1 is the factory default application, providing for basic speed control.

Application 2 supplies speed control using a manual or auto set-point.

Application 3 supplies speed control using preset speeds.

Application 4 supplies speed control using terminal.

Application 5 supplies speed control using PID.

### Control wiring of application



Normally open push-button



2-position switch



Normally open contact (relay)

The default application is 0 this gives complete access to all operating lists in this manual, to select one of the default control application macros select 1 to on parameter F228.

# 13-2 The Default Applications

## 13.1 Application 1: Basic Speed Control

### Standard parameters

- F228 Application
- F111 Max frequency
- F112 Min frequency
- F114 Accel time
- F115 Decel time
- F803 Motor rated current
- F810 Motor rated frequency
- F124 Jog setpoint
- F209 Stop mode
- F137 Torque compensation
- F138 Linear compensation
- F108 Pass word
- F160 Reset to default values

### Application 1:

#### Basic speed control

DIAGNOSTIC S = F131

Frequency Hz = 0

Analog input V = 4

Motor current A = 2

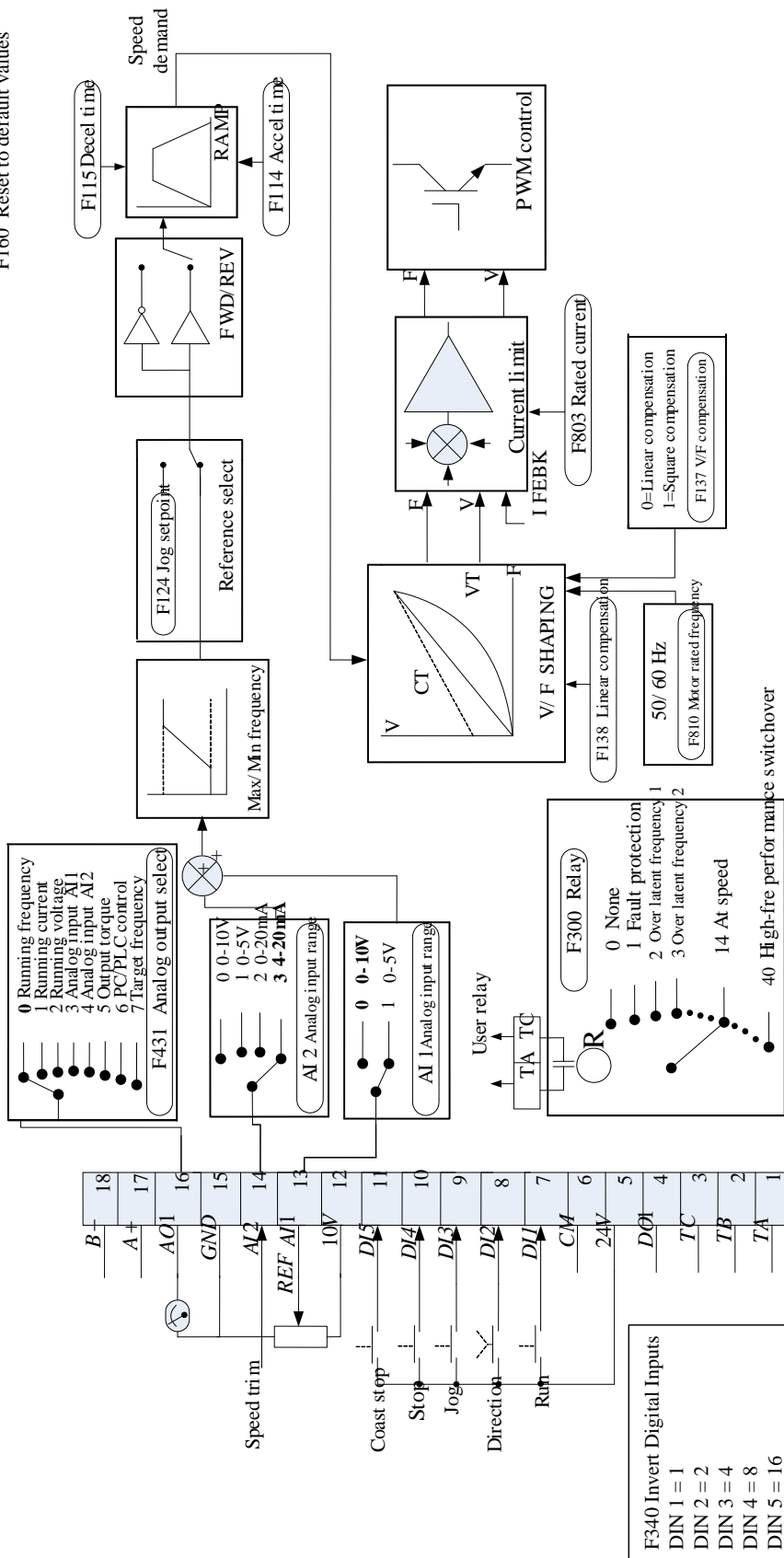
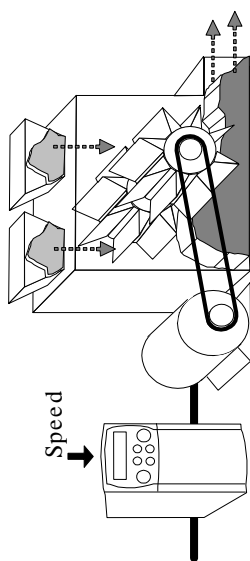



# The Default Applications 13-3

This Application is ideal for general purpose applications. The set-point is the sum of the two analogue inputs AI1 and AI2, providing Speed Set-point + Speed Secondary capability.

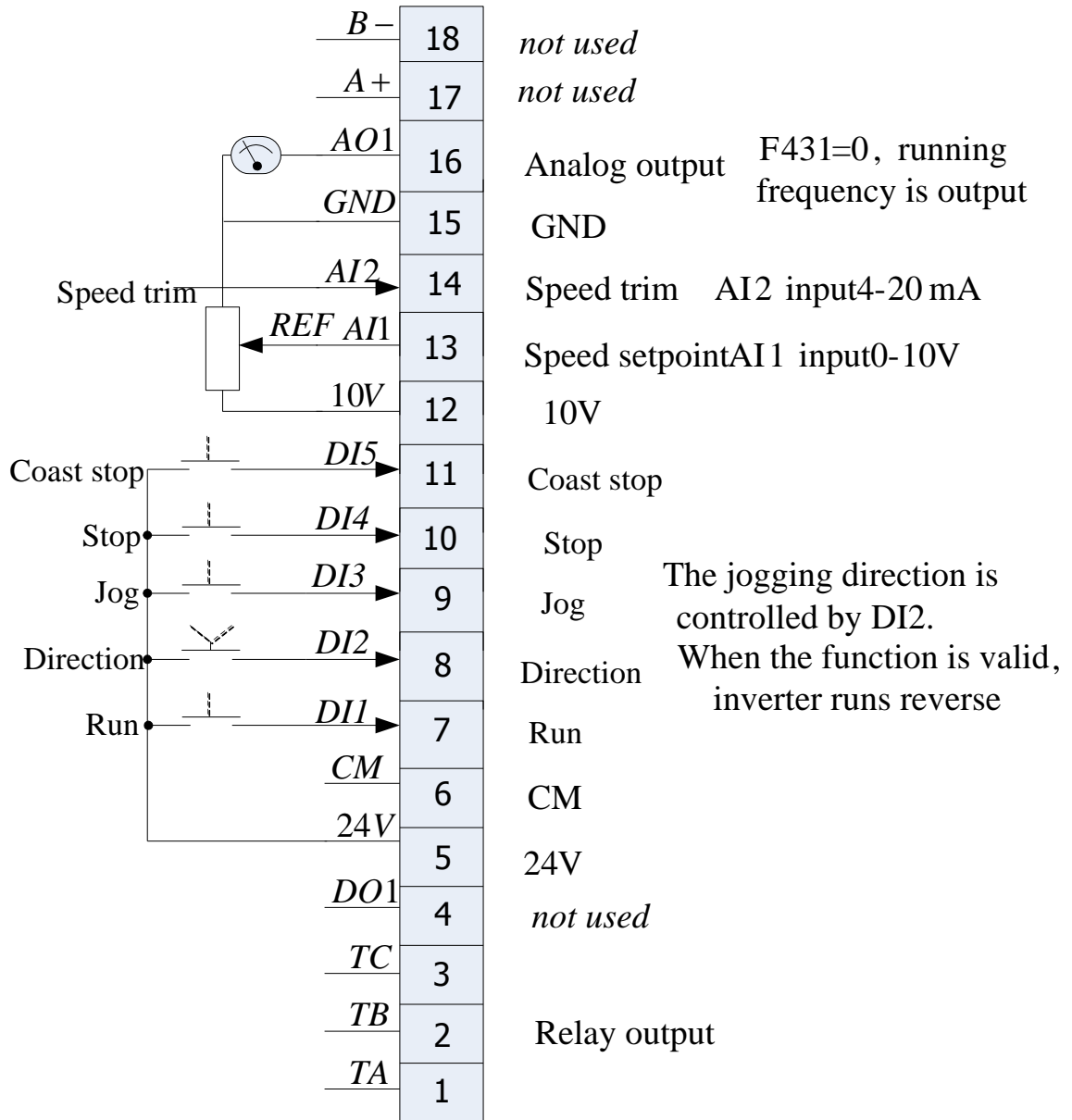

Application 1 : Basic Speed Control  
Parameters Setting:

- F228 = 1
- F106 = 2
- F203 = 1
- F204 = 2
- F207 = 1
- F316 = 1
- F317 = 58
- F318 = 52
- F319 = 2
- F320 = 8
- F431 = 0

# 13-4 The Default Applications

## 13.2 Application 2 : Auto/Manual Control

### Standard parameters

- F228 Application
- F111 Max frequency
- F112 Min frequency
- F114 Accel time
- F115 Decel time
- F803 Motor rated current
- F810 Motor rated frequency
- F124 Jog setpoint
- F209 Stop mode
- F137 Torque compensation
- F138 Linear compensation
- F108 Pass word
- F160 Reset to default values

### Application 2:

#### Auto/Manual control

Ideal for automatic control applications with limit switches or proximity transducers

DIAGNOSTIC S = F131

Frequency Hz = 0

Analog input V = 4

Motor current A = 2

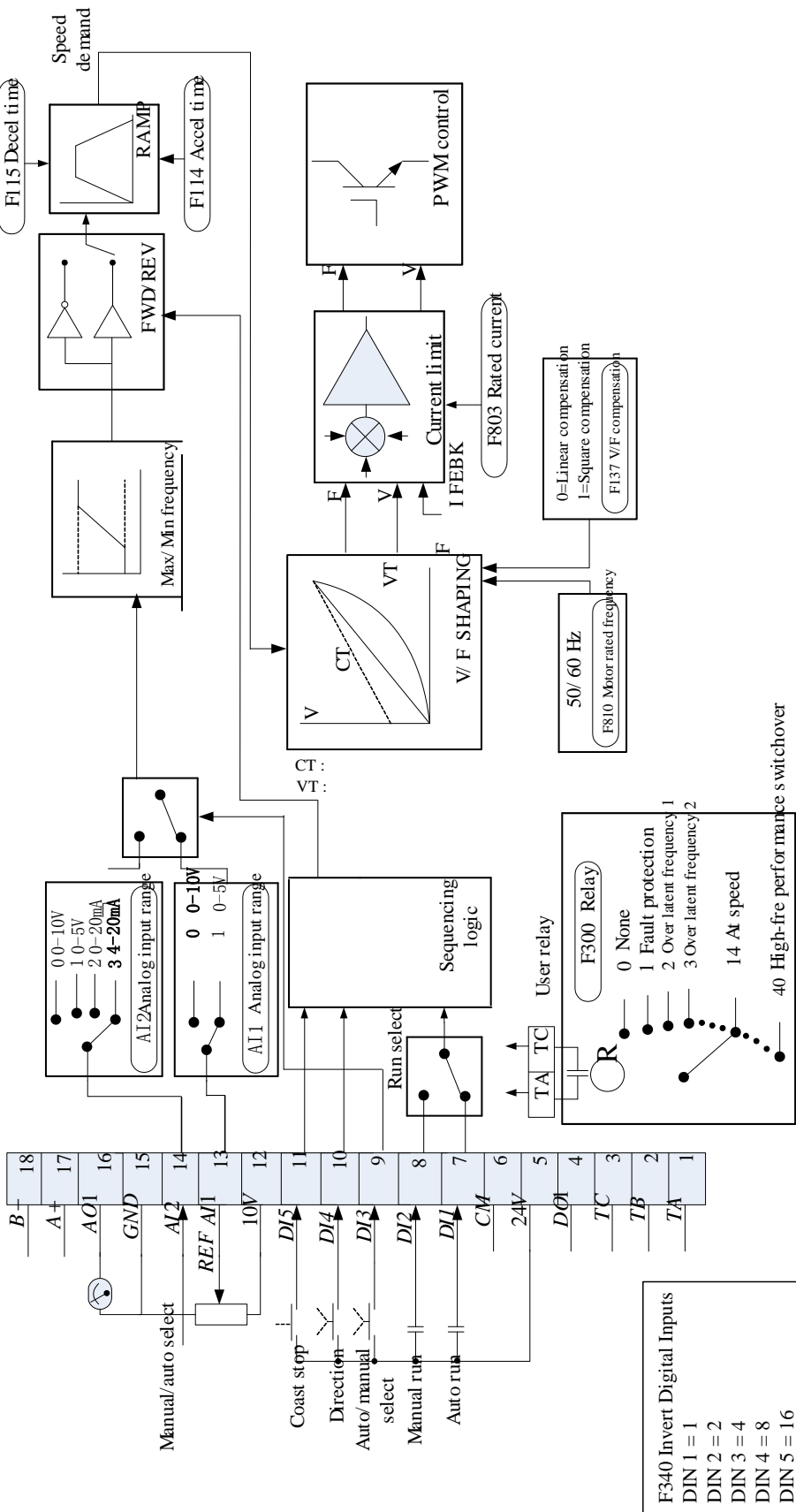
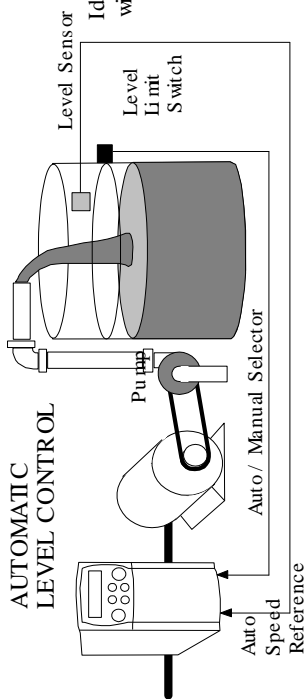

- F340 Invert Digital Inputs**
- DIN 1 = 1
  - DIN 2 = 2
  - DIN 3 = 4
  - DIN 4 = 8
  - DIN 5 = 16

- User relay**
- F300 Relay
- 0 None
  - 1 Fault protection
  - 2 Over latent frequency 1
  - 3 Over latent frequency 2
  - 14 At speed
  - 40 High-fire performance switchover

# The Default Applications 13-5

Two Run inputs and two Set-point inputs are provided. The Auto/Manual switch selects which pair of inputs is active. The Application is sometimes referred to as Local/Remote.

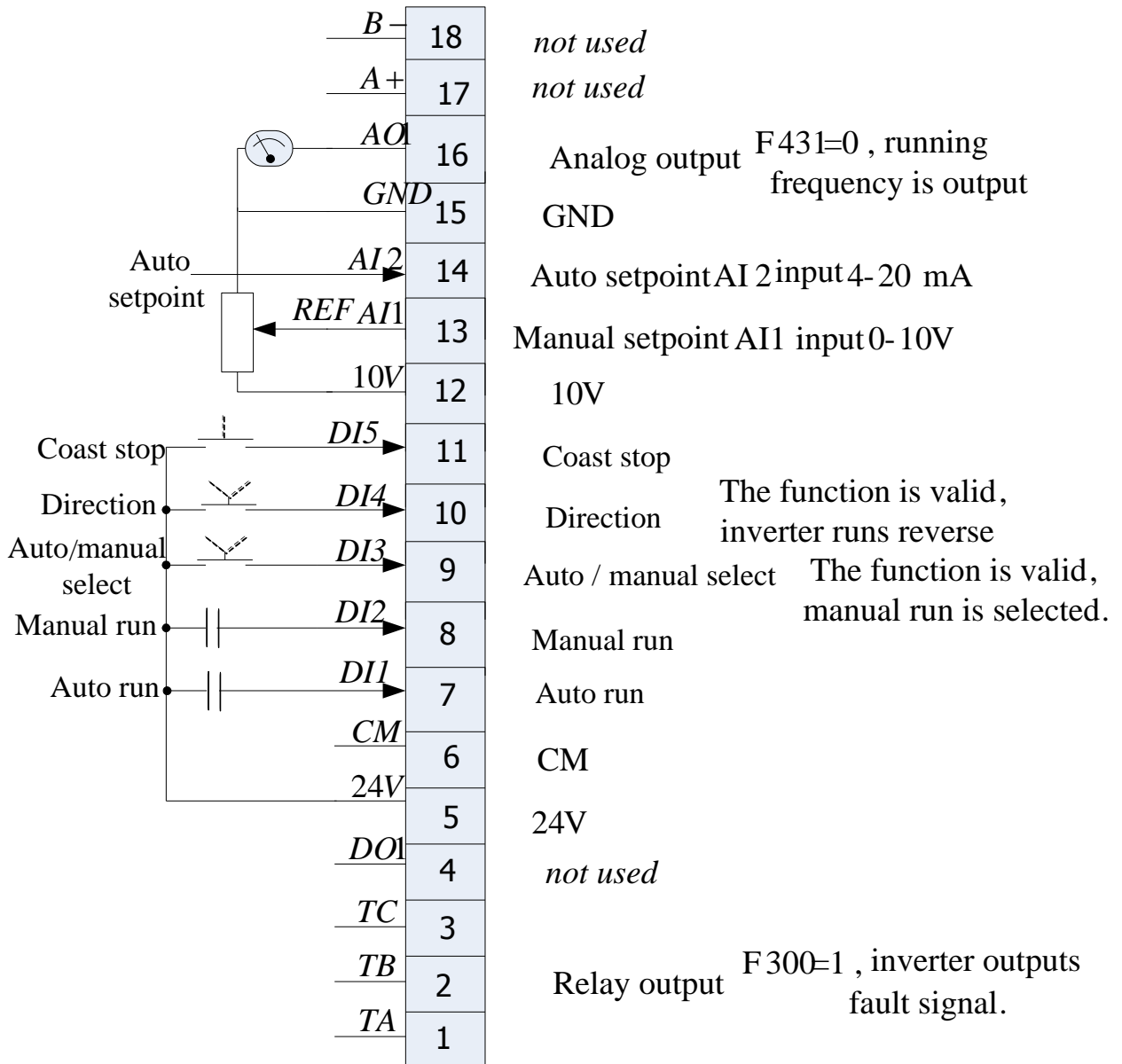

## Application 2 : Auto/Manual Control Parameters Setting:

- F228 = 2
- F106 = 2
- F203 = 1
- F204 = 2
- F207 = 2
- F316 = 56
- F317 = 57
- F318 = 55
- F319 = 58
- F320 = 8
- F431 = 0

# 13-6 The Default Applications

## 13.3 Application 3: Preset Speeds

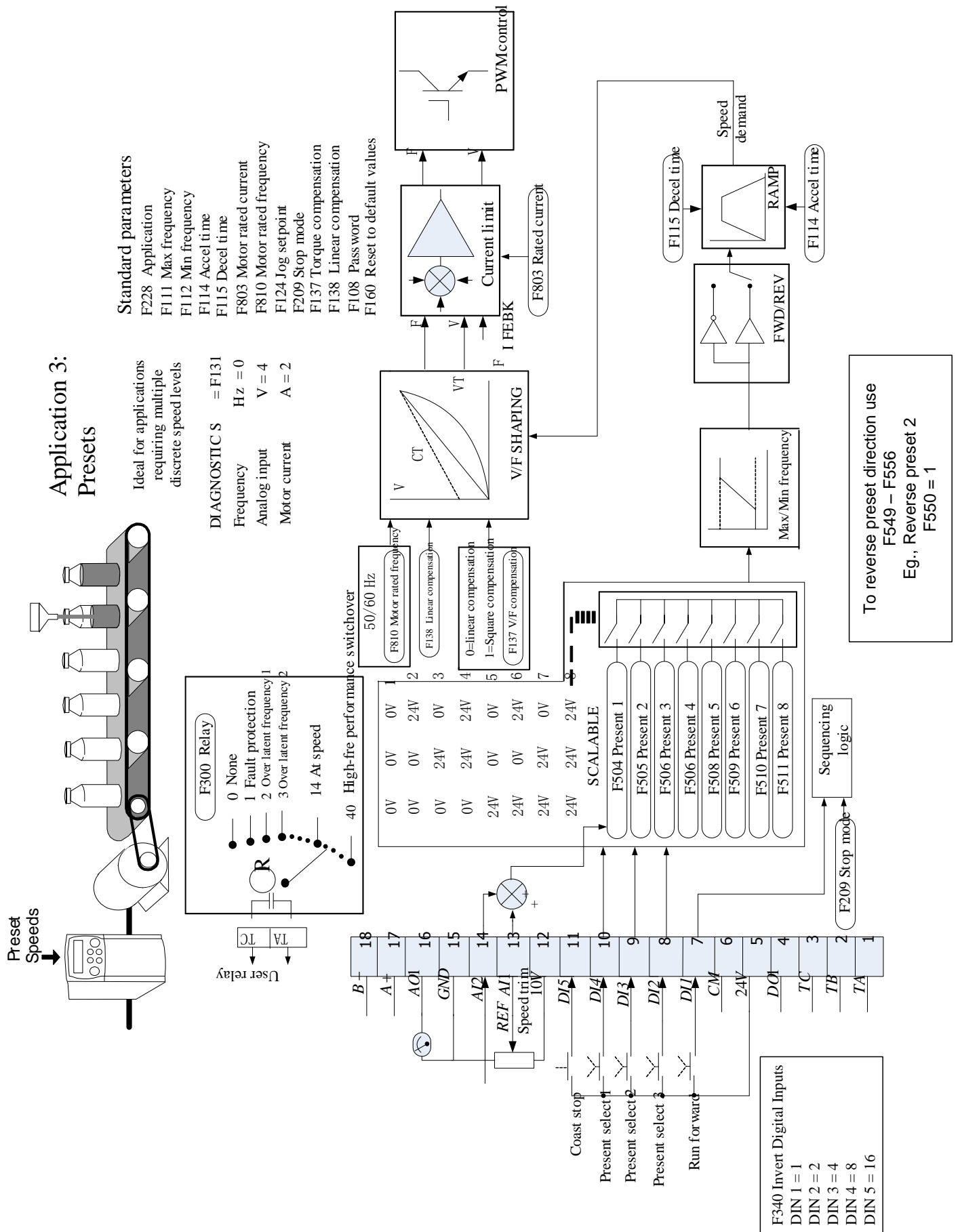

# The Default Applications 13-7

This is ideal for applications requiring multiple discrete speed levels.

The set-point is selected from either the sum of the analogue inputs, or as one of up to eight other pre-defined speed levels. These are selected using DI2, DI3 and DI4, refer to the Truth Table below.

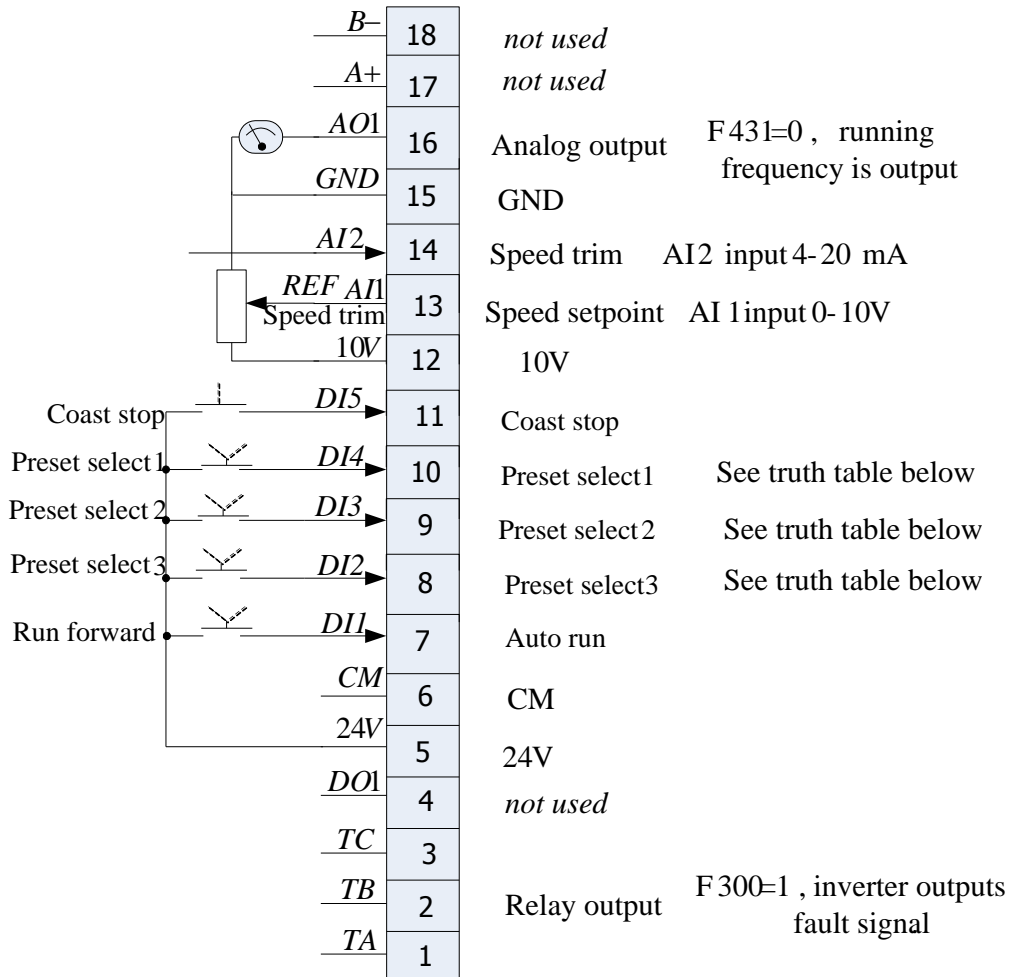

**Preset Speed Truth Table**

DI4	DI3	DI2	Preset
0V	0V	0V	1
0V	0V	24V	2
0V	24V	0V	3
0V	24V	24V	4
24V	0V	0V	5
24V	0V	24V	6
24V	24V	0V	7
24V	24V	24V	8

Application 3: Preset Speeds  
Parameters Setting:

- F223 = 3
- F106 = 2
- F203 = 4
- F204 = 1
- F207 = 1
- F316 = 56
- F317 = 3
- F318 = 4
- F319 = 5
- F320 = 8
- F431 = 0

# 13-8 The Default Applications

## 13.4 Application 4 : Raise/Lower Secondary

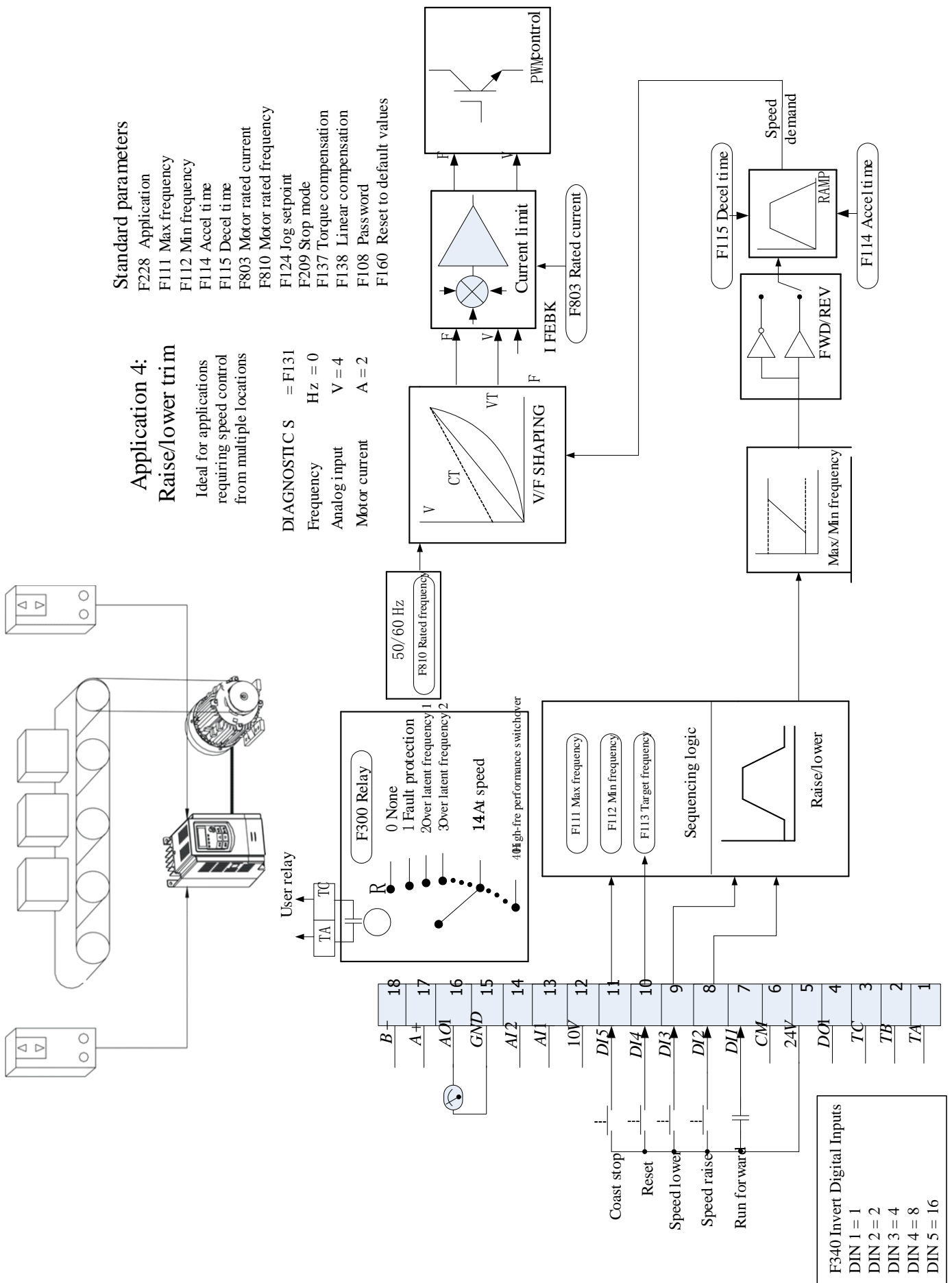

# The Default Applications 13-9

This Application mimics the operation of a motorised potentiometer. Digital inputs allow the set-point to be increased and decreased between limits. The Application is sometimes referred to as motorised Potentiometer.

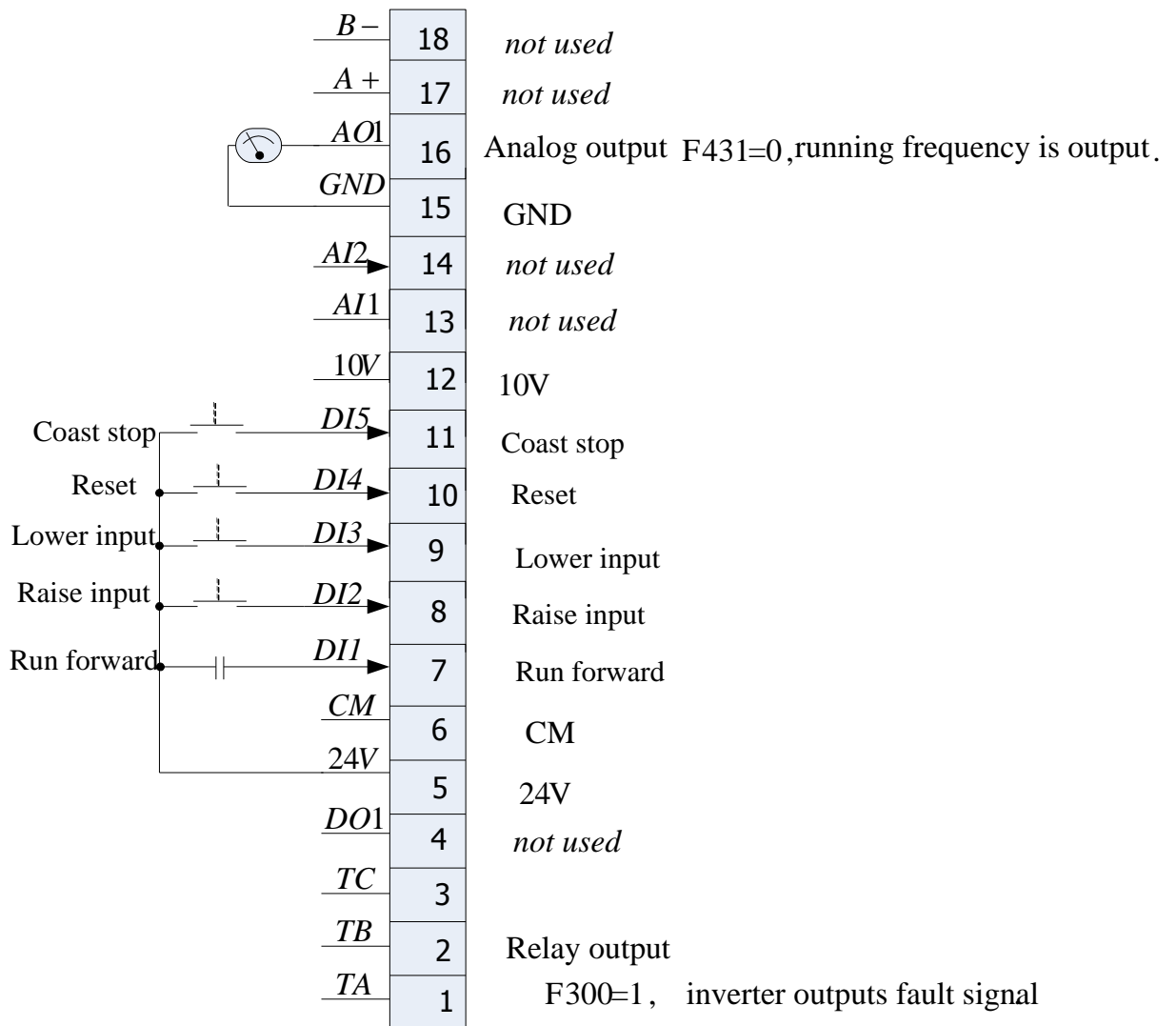

## Application 4 : Raise/Lower Secondary Parameters Setting:

F228 = 4  
 F106 = 2  
 F112 = 0.00  
 F113 = 0.00  
 F224 = 1  
 F203 = 0  
 F208 = 1  
 F316 = 15  
 F317 = 13  
 F318 = 14  
 F319 = 54

# 13-10 The Default Applications

## 13.5 Application 5: PID

### Application 5: PID Control

Easy tuning for setpoint/feedback control applications regulating volume or pressure, such as air handling or pumping.

DIAGNOSTIC S = F131

Frequency Hz = 0

Analog input V = 4

Motor current A = 2

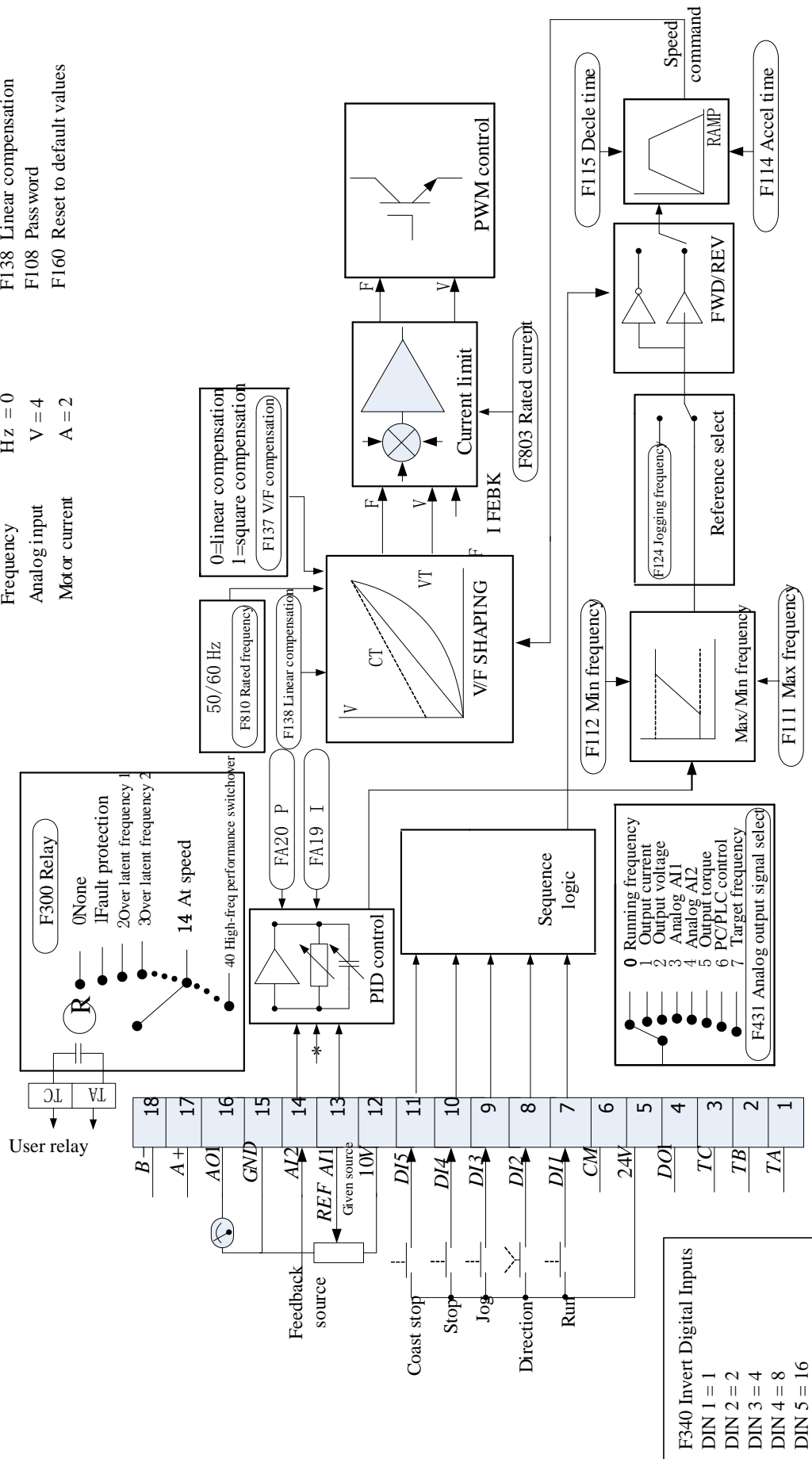
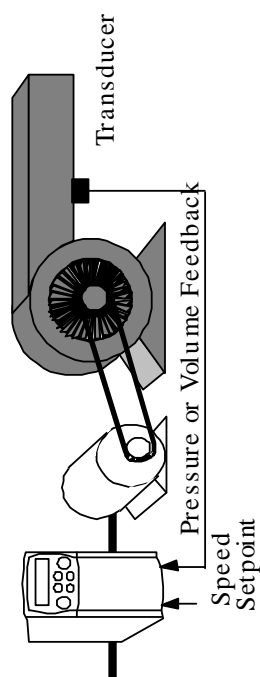

- Standard parameters**
- F228 Application
  - F111 Max frequency
  - F112 Min frequency
  - F114 Accel time
  - F115 Decel time
  - F803 Motor rated current
  - F810 Motor rated frequency
  - F124 Jog setpoint
  - F209 Stop mode
  - F137 Torque compensation
  - F138 Linear compensation
  - F108 Pass word
  - F160 Reset to default values



# The Default Applications 13-11

A simple application using a Proportional-Integral-Derivative 3-term controller. The set-point is taken from AI1, with feedback signal from the process on AI2. The difference between these two signals is taken as the PID error. The output of the PID block is then used as the drive set-point.

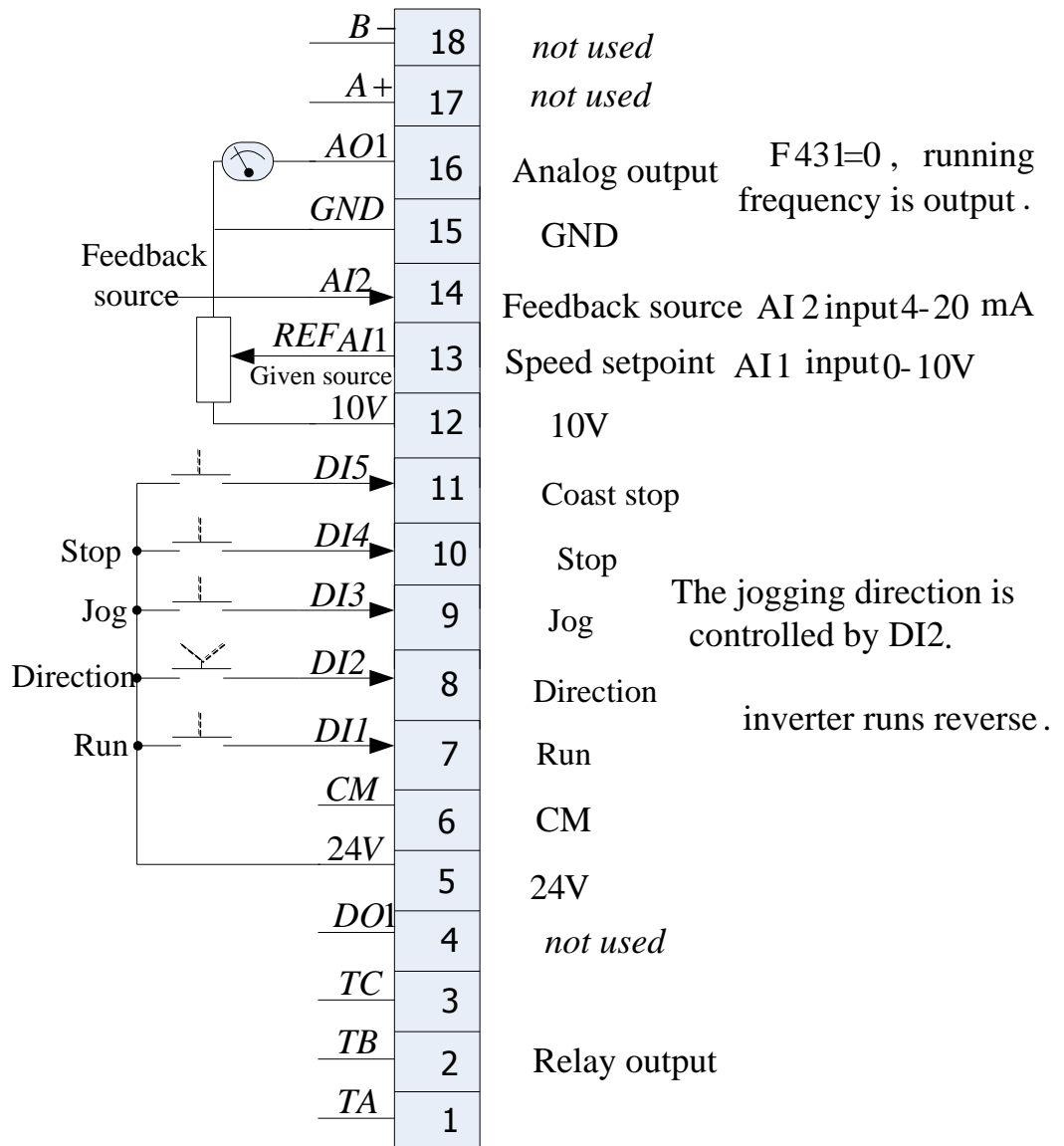

## Application 5 : PID

### Parameters Setting:

F228 = 5  
 F106 = 2  
 F203 = 9  
 F316 = 1  
 F317 = 58  
 F318 = 52  
 F319 = 2  
 F320 = 8  
 F431 = 0  
 FA01 = 1  
 FA02 = 2



## Chapter 14 Compliance

### 14.1 Applicable Standards

EN 61800-3:2004 Adjustable speed electrical power drive systems – Part 3: EMC requirements and specific test methods.

EN 61800-5-1:2007 Adjustable speed electrical power drive systems – Part 5-1: Safety requirements – Electrical, thermal and energy.

EN 61800-5-2:2007 Adjustable speed electrical power drive systems – Part 5-2: Safety requirements – Functional.

EN ISO 13849-1:2008 Safety of machinery – Safety-related parts of control systems – Part 1: General principles for design.

EN 60204-1:2006 Safety of machinery – Electrical equipment of machines – Part 1: General requirements.

EN 61000-3-2:2006 Electromagnetic Compatibility (EMC) - Part 3-2: Limits – Limits for harmonic current emissions (equipment input current up to and including 16A per phase).

IEC 61000-3-12:2011 Electromagnetic compatibility (EMC) – Part 3-12: Limits – Limits for harmonic currents produced by equipment connected to public low-voltage systems with input currents >16A and ≤75A per phase.

EN 61000-6-2:2007 Electromagnetic compatibility (EMC) – Part 6-2: General standards – Immunity for industrial environments.

EN 61000-6-3:2007 Electromagnetic compatibility (EMC) – Part 6-3: General standards - Emission standard for residential, commercial and light-industrial environments.

EN 61000-6-4:2007 Electromagnetic compatibility (EMC) – Part 6-4: General standards – Emission standard for residential, commercial and light-industrial environments.

#### RESTRICTION, EVALUATION, AUTHORISATION AND RESTRICTION OF CHEMICALS (REACH)

The Regulation (EC) No 1907/2006 of the European Parliament and of the Council of 18 December 2006 concerning the Registration, Evaluation, Authorization, and Restriction of Chemicals (REACH) entered into force on June 1, 2007. Parker agrees with the purpose of REACH which is to ensure a high level of protection of human health and the environment. Parker is compliant with all applicable requirements of REACH.

As of 19<sup>th</sup> December 2011 VSD products manufactured and marketed by Parker do not contain substances on the REACH SVHC candidate list in concentrations greater than 0.1% by weight per article. Parker will continue to monitor the developments of the REACH legislation and will communicate with our customers according to the requirement above.

## 14.2 North American & Canadian Compliance Information

### 14.2.1 UL Standards

The UL/cUL mark applies to products in the United States and Canada and it means that UL has performed product testing and evaluation and determined that their stringent standards for product safety have been met. For a product to receive UL certification, all components inside that product must also receive UL certification:



### 14.4.2 UL Standards Compliance

This drive is tested in accordance with UL standard UL508C, File No. E142140 and complies with UL requirements. To ensure continued compliance when using this drive in combination with other equipment, meet the following conditions:

1. Do not install the drive to an area greater than pollution severity 2 (UL standard).
2. Installation and operating instructions shall be provided with each device.

The following markings shall appear in one of the following locations; shipped separately with the device; on a separable, self-adhesive permanent label that is shipped with the device; or anywhere on the device itself:

- a) Designation markings for each wiring diagram;
- b) Markings for proper wiring connections;
- c) "Maximum surrounding air temperature 40°C" or equivalent;
- d) "Solid state motor overload protection reacts when reaches 150% of FLA" or equivalent;
- e) "Install device in pollution degree 2 environment." Or equivalent;
- f) "Suitable for use on a circuit capable of delivering not more than 5,000 rms symmetrical amperes, 480/240 volts maximum when protected by made by COOPER BUSSMANN LLC Class T Fuse." Or equivalent. Recommended input fuse selection listed below:

Frame Size or Model	Fuse Model	Fuse Current Rating
10G-31-0015-XX 10G-31-0025-XX 10G-31-0035-XX 10G-31-0045-XX	JJS-15	15A
10G-32-0050-XX 10G-32-0070-XX 10G-32-0100-XX	JJS-25	25A
10G-11-0015-XX 10G-11-0025-XX 10G-11-0035-XX 10G-11-0045-XX	JJS-15	15A
10G-12-0050-XX 10G-12-0070-XX 10G-12-0010-XX	JJS-25	25A

# 14-3 Compliance

Frame Size or Model	Fuse Model	Fuse Current Rating
10G-41-0006-XX 10G-41-0010-XX 10G-41-0015-XX	JJS-6	6A
10G-42-0020-XX 10G-42-0030-XX 10G-42-0040-XX 10G-42-0065-XX	JJS-15	15A
10G-43-0080-XX 10G-43-0090-XX 10G-43-0120-XX	JJS-30	30A
10G-44-0170-XX	JJS-45	45A
10G-44-0230-XX	JJS-60	60A
10G-45-0320-XX	JJS-80	80A
10G-45-0380-XX	JJS-90	90A
10G-45-0440-XX	JJS-100	100A

- g) “Integral solid state short circuit protection does not provide branch circuit protection. Branch circuit protection must be provided in accordance with the National Electrical Code and any additional local codes” or equivalent;
- h) “CAUTION – Risk of Electric Shock” should be provided, followed by instructions to discharge the Bus Capacitor or indicating the time required (5 minutes) for Bus Capacitor to discharge to a level below 50Vdc;
- i) “Drives have no provision for motor over temperature protection” or equivalent;
- j) For use in Canada only: “TRANSIENT SURGE SUPPRESSION SHALL BE INSTALLED ON THE LINE SIDE OF THIS EQUIPMENT AND SHALL BE RATED \_\_\_480/240\_\_\_V (PHASE TO GROUND), 480/240V (PHASE TO PHASE), SUITABLE FOR OVERVOLTAGE CATEGORY \_III\_, AND SHALL PROVIDE PROTECTION FOR A RATED IMPULSE WITHSTAND VOLTAGE PEAK OF \_ 6Kv” or equivalent.
- k) Field wiring terminal markings – Wiring terminals shall be marked to indicate the proper connections for power supply and load, or a wiring diagram coded to the terminal marking shall be securely attached to the device:
  - l) “Use 60/75°C CU wire” or equivalent;
  - m) Required wire torque, type and range listed below:

Frame Size	Terminal Type	Required Torque (in-lbs)	Wire Range (AWG)	Wire Type
10G-31-0015-XX 10G-31-0025-XX 10G-31-0035-XX 10G-31-0045-XX	Input and Output Terminal Block	10	12	STR/SOL
10G-32-0050-XX 10G-32-0070-XX 10G-32-0100-XX	Input and Output Terminal Block	10	10	STR/SOL
10G-11-0015-XX 10G-11-0025-XX 10G-11-0035-XX	Input and Output Terminal Block	10	14	STR/SOL

Frame Size	Terminal Type	Required Torque (in-lbs)	Wire Range (AWG)	Wire Type
10G-11-0045-XX				
10G-12-0050-XX 10G-12-0070-XX 10G-12-0010-XX	Input and Output Terminal Block	10	14	STR/SOL
10G-41-0006-XX 10G-41-0010-XX 10G-41-0015-XX	Input and Output Terminal Block	6A	14	STR/SOL
10G-42-0020-XX 10G-42-0030-XX 10G-42-0040-XX 10G-42-0065-XX	Input and Output Terminal Block	10	14	STR/SOL
10G-43-0080-XX 10G-43-0090-XX	Input and Output Terminal Block	10.5	14	STR/SOL
10G-43-0120-XX	Input and Output Terminal Block	10.5	10	STR/SOL
10G-44-0170-XX	Input and Output Terminal Block	19	10	STR/SOL
10G-44-0230-XX	Input and Output Terminal Block	30.4	8	STR/SOL
10G-45-0320-XX	Input and Output Terminal Block	30.4	6	STR/SOL
10G-45-0380-XX 10G-45-0440-XX	Input and Output Terminal Block	30.4	4	STR/SOL



Grounding – The pressure wire connector intended for connection for field installed equipment, grounding conductor shall be plainly identified such as being marked “G”, “GRD”, “Ground”, “Grounding”, or equivalent or with the grounding symbol (IEC 417, Symbol 5019).

# 14-5 Compliance

Tightening torque and wire range for field grounding wiring terminals are marked adjacent to the terminal or on the wiring diagram.

Frame Size	Terminal Type	Required Torque (in-lbs)	Wire Range (AWG)
10G-31-0015-XX	Grounding Terminal Block	6.2	8
10G-31-0025-XX			
10G-31-0035-XX			
10G-31-0045-XX			
10G-32-0050-XX			
10G-32-0070-XX			
10G-32-0100-XX			
10G-11-0015-XX			
10G-11-0025-XX			
10G-11-0035-XX			
10G-11-0045-XX			
10G-12-0050-XX			
10G-12-0070-XX			
10G-12-0010-XX			
10G-41-0006-XX			
10G-41-0010-XX			
10G-41-0015-XX			
10G-42-0020-XX			
10G-42-0030-XX			
10G-42-0040-XX			
10G-42-0065-XX			
10G-43-0080-XX			
10G-43-0090-XX			
10G-43-0120-XX			
10G-44-0170-XX			
10G-44-0230-XX			
10G-45-0320-XX			
10G-45-0380-XX			
10G-45-0440-XX			

14.3 Declaration

AC10 Series Variable Speed Drives	
 <p style="text-align: center;">Manufacturers EC Declarations of Conformity Date CE marked first applied: 01/12/13</p>	
EMC Directive	Low Voltage Directive
<p>In accordance with the EC Directive 2004/108/EC</p> <p>We Parker Hannifin Manufacturing Limited, address as below, declare under our sole responsibility that the above Electronic Products when installed and operated with reference to the instructions in the Product Manual (provided with each piece of equipment) is in accordance with the relevant clauses from the following standards:-</p> <p>EN 61800-3 (2004)(+A1:2012)</p> <p>Note: Filtered versions</p>	<p>In accordance with the EC Directive 2006/95/EC</p> <p>We Parker Hannifin Manufacturing Limited, address as below, declare under our sole responsibility that the above Electronic Products when installed and operated with reference to the instructions in the Product Manual (provided with each piece of equipment), is in accordance with the following standard :-</p> <p>EN 61800-5-1 (2007)</p>
Manufacturers Declarations of Conformity	
EMC Declaration	Low Voltage and Machinery Directives
<p>We Parker Hannifin Manufacturing Limited, address as below, declare under our sole responsibility that the above Electronic Products when installed and operated with reference to the instructions in the Product Manual (provided with each piece of equipment) is in accordance with the relevant clauses from the following standards:-</p> <p>BSEN61800-3 (2004)(+A1:2012)</p> <p>Notes:</p> <p>Non-filtered versions</p> <p>This is provided to aid justification for EMC Compliance when the unit is used as a component.</p>	<p>The above Electronic Products are components to be incorporated into machinery and may not be operated alone.</p> <p>The complete machinery or installation using this equipment may only be put into service when all safety considerations of the Directive 2006/42/EC are fully implemented.</p> <p>Particular reference should be made to EN60204-1 (Safety of Machinery - Electrical Equipment of Machines).</p> <p>All instructions, warnings and safety information of the Product Manual must be implemented.</p>
<div style="display: flex; justify-content: space-between; align-items: flex-start;"> <div style="width: 45%;">  </div> <div style="width: 45%;"> <p>Mr. Jonathan McCormick (UK Quality Assurance &amp; Compliance Manager)</p> </div> </div> <p style="font-size: small; margin-top: 10px;">Parker Hannifin Manufacturing Limited, Automation Group, SSD Drives Europe, NEW COURTWICK LANE, LITTLEHAMPTON, WEST SUSSEX BN17 7RZ TELEPHONE: +44 (0) 1903 737000, FAX: +44 (0)1903 737100 Registered Number 4806503 England. Registered Office: 55 Maylands Avenue, Hemel Hempstead, Herts HP2 4SJ</p>	



# 15-1 Parameter Reference

## Chapter 15 Parameter Reference

### Basic parameters: F100-F160

Function Code	Function Definition	Setting Range	Mfr's Value	Change
F100	User's Password	0~9999		√
F102	Inverter's Rated Current (A)		Subject to inverter model	○
F103	Inverter Power (kW)		Subject to inverter model	○
F104	Reserved			
F105	Software Edition No.		Subject to inverter model	△
F106	Control Mode	Setting range: 0:Sensorless vector control (SVC); 1: Reserved; 2: VVVF 3: Vector control 1 6 (Synchronous motor control mode)	2	×
F107	Password Valid or Not	0: invalid; 1: valid	0	√
F108	Setting User's Password	0~9999	8	√
F109	Starting Frequency (Hz)	0.0~10.00Hz	0.0	√
F110	Holding Time of Starting Frequency (S)	0.0~999.9	0.0	√
F111	Max Frequency (Hz)	F113~590.0Hz	50.00	√
F112	Min Frequency (Hz)	0.00Hz~F113	0.50	√
F113	Target Frequency (Hz)	F112~F111	50.00	√
F114	1 <sup>st</sup> Acceleration Time (S)	0.1~3000	subject to inverter model	√
F115	1 <sup>st</sup> Deceleration Time (S)	0.1~3000		√
F116	2 <sup>nd</sup> Acceleration Time (S)	0.1~3000		√
F117	2 <sup>nd</sup> Deceleration Time (S)	0.1~3000		√
F118	Base Frequency (Hz)	15.00~590.0	50.00	×
F119	Reference of Setting Accel/Decel Time	0: 0~50.00Hz 1: 0~ F111	0	×
F120	Forward/Reverse Switchover Dead-Time	0.0~3000	0.0	√
F121	Reserved			
F122	Reverse Running Forbidden	0: invalid; 1: valid	0	×
F123	Minus Frequency is Valid in the Mode of Combined Speed Control.	0: Invalid; 1: valid	0	×
F124	Jogging Frequency	F112~F111	5.00Hz	√
F125	Jogging Acceleration Time	0.1~3000S	subject to inverter model	√
F126	Jogging Deceleration Time	0.1~3000S		√

Function Code	Function Definition	Setting Range	Mfr's Value	Change
F127	Skip Frequency A	0.00~590.0Hz	0.00	√
F128	Skip Width A	±2.50Hz	0.00	√
F129	Skip Frequency B	0.00~590.0Hz	0.00	√
F130	Skip Width B	±2.50Hz	0.00	√
F131	Running Display Items	0— Output frequency / function code 1— Output rotary speed 2— Output current 4— Output voltage 8— PN voltage 16— PID feedback value 32— Temperature 64— Reserved 128— Linear speed 256— PID given value 512— Reserved 1024— Reserved 2048— Output power 4096— Output torque	0+1+2+4+8=15	√
F132	Display Items of Stop	0: frequency / function code 1: Keypad jogging 2: Target rotary speed 4: PN voltage 8: PID feedback value 16: Temperature 32: Reserved 64: PID given value 128: Reserved 256: Reserved 512: Setting torque	2+4=6	√
F133	Drive Ratio of Driven System	0.10~200.0	1.0	√
F134	Transmission-wheel Radius	0.001~1.000	0.001	√
F135	Reserved			
F136	Slip Compensation	0~10	0	×
F137	Modes of Torque Compensation	0: Linear compensation; 1: Square compensation; 2: User-defined multipoint compensation 3: Auto torque compensation	3	×
F138	Linear Compensation	1~20	subject to inverter model	×
F139	Square Compensation	1: 1.5;      2: 1.8; 3: 1.9;      4: 2.0	1	×

## 15-3 Parameter Reference

Function Code	Function Definition	Setting Range	Mfr's Value	Change
F140	User-defined Frequency Point 1	0~F142	1.00	X
F141	User-defined voltage point 1	0~100%	4	X
F142	User-defined frequency point 2	F140~F144	5.00	X
F143	User-defined voltage point 2	0~100%	13	X
F144	User-defined frequency point 3	F142~F146	10.00	X
F145	User-defined voltage point 3	0~100%	24	X
F146	User-defined frequency point 4	F144~F148	20.00	X
F147	User-defined voltage point 4	0~100%	45	X
F148	User-defined frequency point 5	F146~F150	30.00	X
F149	User-defined voltage point 5	0~100%	63	X
F150	User-defined frequency point 6	F148~F118	40.00	X
F151	User-defined voltage point 6	0~100%	81	X
F152	Output voltage corresponding to turnover frequency	10~100%	100	X
F153	Carrier frequency setting	subject to inverter model	subject to inverter model	X
F154	Automatic voltage rectification	Setting range: 0: Invalid 1: Valid 2:Invalid during deceleration process	0	X
F155	Digital secondary frequency setting	0~F111	0	X
F156	Digital secondary frequency polarity setting	0~1	0	X
F157	Reading secondary frequency			Δ
F158	Reading secondary frequency polarity			Δ
F159	Random carrier-wave frequency selection	0: Control speed normally; 1: Random carrier-wave frequency	1	
F160	Reverting to manufacturer values	0: Not reverting to manufacturer values; 1: Reverting to manufacturer values	0	X

## Running control mode: F200-F230

Function Code	Function Definition	Setting Range	Mfr's Value	Change
F200	Source of start command	0: Keypad command; 1: Terminal command; 2: Keypad+ Terminal; 3:MODBUS; 4: Keypad+ Terminal+ MODBUS	4	X
F201	Source of stop command	0: Keypad command; 1: Terminal command; 2: Keypad+ Terminal; 3:MODBUS; 4: Keypad+ Terminal+MODBUS	4	X
F202	Mode of direction setting	0: Forward running locking; 1: Reverse running locking; 2: Terminal setting	0	X
F203	Main frequency source X	0: Digital setting memory; 1: External analog AI1; 2: External analog AI2; 3: Reserved; 4: Stage speed control; 5: No memory by digital setting; 6: Reserved;; 7: Reserved; 8: Reserved; 9: PID adjusting; 10: MODBUS	0	X
F204	Secondary frequency source Y	0: Digital setting memory; 1: External analog AI1; 2: External analog AI2; 3: Reserved;; 4: Stage speed control; 5: PID adjusting; 6: Reserved;;	0	X
F205	Reference for selecting secondary frequency source Y range	0: Relative to max frequency; 1: Relative to main frequency X	0	X
F206	Secondary frequency Y range	0~100%	100	X
F207	Frequency source selecting	0: X; 1: X+Y; 2: X or Y (terminal switchover); 3: X or X+Y (terminal switchover); 4: Combination of stage speed and analog 5: X-Y 6: Reserved;	0	X

## 15-5 Parameter Reference

Function Code	Function Definition	Setting Range	Mfr's Value	Change
F208	Terminal two-line/three-line operation control	0: No function; 1: Two-line operation mode 1; 2: Two-line operation mode 2; 3: three-line operation mode 1; 4: three-line operation mode 2; 5: start/stop controlled by direction pulse	0	X
F209	Selecting the mode of stopping the motor	0: stop by deceleration time; 1: free stop	0	X
F210	Frequency display accuracy	0.01~2.00	0.01	√
F211	Speed of digital control	0.01~100.00Hz/S	5.00	√
F212	Direction memory	0: Invalid 1: Valid	0	√
F213	Auto-starting after repowered on	0: invalid; 1: valid	0	√
F214	Auto-starting after reset	0: invalid; 1: valid	0	√
F215	Auto-starting delay time	0.1~3000.0	60.0	√
F216	Times of auto-starting in case of repeated faults	0~5	0	√
F217	Delay time for fault reset	0.0~10.0	3.0	√
F218	Reserved			
F219	Write EEPORM by Modbus	1: invalid; 0: valid	1	√
F220	Frequency memory after power-down	0: invalid; 1: valid	0	√
F221-F223	Reserved			
F224	When target frequency is lower than Min frequency	0: Stop 1: run at min frequency	1	√
F225-F227	Reserved			
F228	Application selection	0: Invalid 1: Basic speed control 2: auto/manual control 3: Stage speed control 4: Terminal control; 5: PID control;	0	
F229~F230	Reserved			

## Multifunctional Input and Output Terminals: F300-F330

Function Code	Function Definition	Setting Range	Mfr's Value	Change
F300	Relay token output	0: no function; 1: inverter fault protection; 2: over latent frequency 1; 3: over latent frequency 2; 4: free stop; 5: in running status 1; 6: DC braking; 7: accel/decel time switchover; 8-9: Reserved; 10: inverter overload pre-alarm; 11: motor overload pre-alarm; 12: stalling; 13: Inverter is ready to run 14: in running status 2; 15: frequency arrival output; 16: overheat pre-alarm; 17: over latent current output 18: Analog line disconnection protection 19: Reserved; 20: Zero current detecting output 21: DO1 controlled by PC/PLC 22: Reserved; 23: TA, TC fault relay output controlled by PC/PLC 24: Watchdog 25-39: Reserved; 40: High-frequency performance switchover	1	√
F301	DO1 token output		14	√
			5	
F303- F306	Reserved			
F307	Characteristic frequency 1	F112~F111	10.00	√
F308	Characteristic frequency 2	F112~F111	50.00	√
F309	Characteristic frequency width (%)	0~100	50	√
F310	Characteristic current (A)	0~1000	Rated current	√
F311	Characteristic current width (%)	0~100	10	√
F312	Frequency arrival threshold (Hz)	0.00~5.00	0.00	√
F313- F315	Reserved			

# 15-7 Parameter Reference

Function Code	Function Definition	Setting Range	Mfr's Value	Change
F316	DI1 terminal function setting	0: no function;	11	√
F317	DI2 terminal function setting	1: running terminal;	9	√
F318	DI3 terminal function setting	2: stop terminal;	15	√
F319	DI4 terminal function setting	3: multi-stage speed terminal 1;	16	√
F320	DI5 terminal function setting	4: multi-stage speed terminal 2; 5: multi-stage speed terminal 3; 6: multi-stage speed terminal 4; 7: reset terminal; 8: free stop terminal; 9: external emergency stop terminal; 10: acceleration/deceleration forbidden terminal; 11: forward run jogging; 12: reverse run jogging; 13: UP frequency increasing terminal; 14: DOWN frequency decreasing terminal; 15: "FWD" terminal; 16: "REV" terminal; 17: three-line type input "X" terminal; 18: accel/decel time switchover 1; 19: Reserved; 20: Reserved; 21: frequency source switchover terminal; 32: Fire pressure switchover 33: Emergency fire control 34: Accel / decel switchover 2 37: Common-open PTC heat protection 38: Common-close PTC heat protection 48: High-frequency switchover 52: Jogging (no direction) 53: Watchdog 54: Frequency reset 55: switchover between manual running and auto running 56: Manual running 57: Auto running 58: Direction	7	√
F324	Free stop terminal logic	0: positive logic (valid for low level);	0	×
F325	External emergency stop terminal logic	1: negative logic (valid for high level)	0	×
F326	Watchdog time	0.0~3000.0	10.0	√
F327	Stop mode	0: Free stop 1: Deceleration to stop	0	×
F328	Terminal filter times	1~100	10	√

Function Code	Function Definition	Setting Range	Mfr's Value	Change
F329	Reserved			
F330	Diagnostics of DIX terminal			△
F331	Monitoring AI1			△
F332	Monitoring AI2			△
F335	Relay output simulation	Setting range: 0: Output active. 1: Output inactive.	0	×
F336	DO1 output simulation		0	×
F338	AO1 output simulation	Setting range: 0~4095	0	×
F340	Selection of terminal negative logic	0: Invalid 1: DI1 negative logic 2: DI2 negative logic 4: DI3 negative logic 8: DI4 negative logic 16: DI5 negative logic	0	√

#### Analog Input and Output: F400-F480

Function Code	Function Definition	Setting Range	Mfr's Value	Change
F400	Lower limit of AI1 channel input	0.00~F402	0.01	√
F401	Corresponding setting for lower limit of AI1 input	0~F403	1.00	√
F402	Upper limit of AI1 channel input	F400~10.00	10.00	√
F403	Corresponding setting for upper limit of AI1 input	Max (1.00, F401) ~2.00	2.00	√
F404	AI1 channel proportional gain K1	0.0~10.0	1.0	√
F405	AI1 filtering time constant	0.01~10.0	0.10	√
F406	Lower limit of AI2 channel input	0.00~F408	0.01V	√
F407	Corresponding setting for lower limit of AI2 input	0~F409	1.00	√
F408	Upper limit of AI2 channel input	F406~10.00	10.00V	√
F409	Corresponding setting for upper limit of AI2 input	Max (1.00, F407) ~2.00	2.00	√
F410	AI2 channel proportional gain K2	0.0~10.0	1.0	√
F411	AI2 filtering time constant	0.01~10.0	0.10	√
F418	AI1 channel 0Hz voltage dead zone	0~0.50V (Positive-Negative)	0.00	√
F419	AI2 channel 0Hz voltage dead zone	0~0.50V (Positive-Negative)	0.00	√
F421	Panel selection	0: Local keypad panel 1: Remote control keypad panel 2: Local keypad + remote control keypad	1	√
F422	Reserved			



# 15-9 Parameter Reference

F423	AO1 output range	0: 0~5V; 1: 0~10V or 0-20mA 2: 4-20mA	1	√
F424	AO1 lowest corresponding frequency	0.0~F425	0.05Hz	√
F425	AO1 highest corresponding frequency	F424~F111	50.00Hz	√
F426	AO1 output compensation	0~120	100	√
F427- F430	Reserved			
F431	AO1 analog output signal selecting	0: Running frequency; 1: Output current; 2: Output voltage; 3: Analog AI1; 4: Analog AI2; 6: Output torque; 7: Given by PC/PLC; 8: Target frequency	0	√
F433	Corresponding current for full range of external voltmeter	0.01~5.00 times of rated current	2	×
F434	Corresponding current for full range of external ammeter		2	×
F435- F436	Reserved			
F437	Analog filter width	1~100	10	*
F438- F459	Reserved			
F460	AI1channel input mode	0: straight line mode 1: folding line mode	0	×
F461	AI2 channel input mode	0: straight line mode 1: folding line mode	0	×
F462	AI1 insertion point A1 voltage value	F400~F464	2.00V	×
F463	AI1 insertion point A1 setting value	F401~F465	1.20	×
F464	AI1 insertion point A2 voltage value	F462~F466	5.00V	×
F465	AI1 insertion point A2 setting value	F463~F467	1.50	×
F466	AI1 insertion point A3 voltage value	F464~F402	8.00V	×
F467	AI1 insertion point A3 setting value	F465~F403	1.80	×
F468	AI2 insertion point B1 voltage value	F406~F470	2.00V	×
F469	AI2 insertion point B1 setting value	F407~F471	1.20	×
F470	AI2 insertion point B2 voltage value	F468~F472	5.00V	×
F471	AI2 insertion point B2 setting value	F469~F473	1.50	×
F472	AI2 insertion point B3 voltage value	F470~F412	8.00V	×
F473	AI2 insertion point B3 setting value	F471~F413	1.80	×

## Multi-stage Speed Control: F500-F580

Function Code	Function Definition	Setting Range	Mfr's Value	Change
F500	Stage speed type	0: 3-stage speed; 1: 15-stage speed; 2: Max 8-stage speed auto circulating	1	X
F501	Selection of Stage Speed Under Auto-circulation Speed Control	2~8	7	√
F502	Selection of Times of Auto- Circulation Speed Control	0~9999 (when the value is set to 0, the inverter will carry out infinite circulating)	0	√
F503	Status after auto circulation running Finished	0: Stop 1: Keep running at last stage speed	0	√
F504	Frequency setting for stage 1 speed	F112~F111	5.00Hz	√
F505	Frequency setting for stage 2 speed	F112~F111	10.00Hz	√
F506	Frequency setting for stage 3 speed	F112~F111	15.00Hz	√
F507	Frequency setting for stage 4 speed	F112~F111	20.00Hz	√
F508	Frequency setting for stage 5 speed	F112~F111	25.00Hz	√
F509	Frequency setting for stage 6 speed	F112~F111	30.00Hz	√
F510	Frequency setting for stage 7 speed	F112~F111	35.00Hz	√
F511	Frequency setting for stage 8 speed	F112~F111	40.00Hz	√
F512	Frequency setting for stage 9 speed	F112~F111	5.00Hz	√
F513	Frequency setting for stage 10 speed	F112~F111	10.00Hz	√
F514	Frequency setting for stage 11 speed	F112~F111	15.00Hz	√
F515	Frequency setting for stage 12 speed	F112~F111	20.00Hz	√
F516	Frequency setting for stage 13 speed	F112~F111	25.00Hz	√
F517	Frequency setting for stage 14 speed	F112~F111	30.00Hz	√
F518	Frequency setting for stage 15 speed	F112~F111	35.00Hz	√
F519-F533	Acceleration time setting for the speeds from Stage 1 to stage 15	0.1~3000S	Subject to inverter model	√
F534-F548	Deceleration time setting for the speeds from Stage 1 to stage 15	0.1~3000S		√
F549-F556	Running directions of stage speeds from Stage 1 to stage 8	0: forward running; 1: reverse running	0	√
F557-F564	Running time of stage speeds from Stage 1 to stage 8	0.1~3000S	1.0S	√
F565-F572	Stop time after finishing stages from Stage 1 to stage 8.	0.0~3000S	0.0S	√
F573-F579	Running directions of stage speeds from Stage 9 to stage 15.	0: forward running; 1: reverse running	0	√
F580	Reserved			

# 15-11 Parameter Reference

## Auxiliary Functions: F600-F670

Function Code	Function Definition	Setting Range	Mfr's Value	Change
F600	DC Braking Function Selection	0: Invalid; 1: braking before starting; 2: braking during stopping; 3: braking during starting and stopping	0	×
F601	Initial Frequency for DC Braking	0.20~50.00	1.00	√
F602	DC Braking efficiency before Starting	0~100	10	√
F603	DC Braking efficiency During Stop	0~100	10	√
F604	Braking Lasting Time Before Starting	0.00~30.00	0.50	√
F605	Braking Lasting Time During Stopping	0.00~30.00	0.50	√
F606	Reserved			
F607	Selection of Stalling Adjusting Function	0: invalid; 1: valid 2: Reserved 3: Voltage current control 4: Voltage control 5: Current control	0	√
F608	Stalling Current Adjusting (%)	60~200	160	√
F609	Stalling Voltage Adjusting (%)	110~200	1 phase: 130 3 phase: 140	√
F610	Stalling Protection Judging Time	0.1~3000	60.0	√
F611	Dynamic Braking Threshold (V)	200~1000	Subject to inverter model	△
F612	Dynamic Braking Duty Ratio (%)	0~100%	80	×
F613	Flycatching	0: invalid 1: valid 2: valid at the first time	0	×
F614	Flycatching Rate Mode	0: Flycatching from frequency memory 1: Flycatching from max frequency 2: Flycatching from frequency memory and direction memory 3: Flycatching from max frequency and direction memory	0	×
F615	Flycatching Rate	1~100	20	×
F613-F621	Reserved			
F622	Dynamic Braking Mode	0: Fixed duty ratio 1: Auto duty ratio	0	√
F627	Current Limiting when Flycatching	50-200	100	×
F631	VDC Adjustment Selection	0: invalid 1: valid	0	√

F632	Target voltage of VDC adjuster (V)	200-800	Subject to inverter model	√ ○
F633- F649	Reserved			
F650	High-frequency performance	Setting range: 0: Invalid 1: Terminal enabled 2: Enabled mode 1 3: Enabled mode 2	2	× ○
F651	Switchover frequency 1	F652-150.00	100.00	√ ○
F652	Switchover frequency 2	0-F651	95.00	√ ○
F653- F670	Reserved			

### Timing Control and Protection: F700-F770

Function Code	Function Definition	Setting Range	Mfr's Value	Change
F700	Selection of terminal free stop mode	0: free stop immediately; 1: delayed free stop	0	√
F701	Delay time for free stop and programmable terminal action	0.0~60.0s	0.0	√
F702	Fan control mode	0:controlled by temperature 1: Running when inverter is powered on 2: Controlled by running status	2	√
F703	Reserved			
F704	Inverter Overloading pre-alarm Coefficient (%)	50~100	80	×
F705	Overloading adjusting gains	50~100	80	×
F706	Inverter Overloading coefficient%	120~190	150	×
F707	Motor Overloading coefficient %	20~100	100	×
F708	Record of The Latest Malfunction Type	Setting range: 2: Over current (OC) 3: over voltage (OE)		Δ
F709	Record of Malfunction Type for Last but One	4: input phase loss (PF1) 5: inverter overload (OL1)		Δ
F710	Record of Malfunction Type for Last but Two	6: under voltage (LU) 7: overheat (OH) 8: motor overload (OL2) 11: external malfunction (ESP) 13. studying parameters without motor (Err2) 16: Over current 1 (OC1) 17: output phase loss (PF0) 18: Aerr analog disconnected 23: Err5 PID parameters are set wrong		Δ

# 15-13 Parameter Reference

Function Code	Function Definition	Setting Range	Mfr's Value	Change
		45: Communication Timeout (CE) 46: Flycatching fault (FL) 24: Communication timeout (CE)		
F711	Fault Frequency of The Latest Malfunction			△
F712	Fault Current of The Latest Malfunction			△
F713	Fault PN Voltage of The Latest Malfunction			△
F714	Fault Frequency of Last Malfunction but One			△
F715	Fault Current of Last Malfunction but One			△
F716	Fault PN Voltage of Last Malfunction but One			△
F717	Fault Frequency of Last Malfunction but Two			△
F718	Fault Current of Last Malfunction but Two			△
F719	Fault PN Voltage of Last Malfunction but Two			△
F720	Record of Overcurrent Protection Fault Times			△
F721	Record of Overvoltage Protection Fault Times			△
F722	Record of Overheat Protection Fault Times			△
F723	Record of Overload Protection Fault Times			△
F724	Input Phase Loss	0: invalid; 1: valid	1	○X
F725	Reserved			
F726	Overheat	0: invalid; 1: valid	1	○X
F727	Output Phase Loss	0: invalid; 1: valid	0	○
F728	Input Phase Loss Filtering Constant	0.1~60.0	0.5	√
F730	Overheat Protection Filtering Constant	0.1~60.0	5.0	√
F732	Voltage Threshold of Under-voltage Protection	0~450	Subject to inverter model	○
F737	Over-current 1 Protection	0: Invalid 1:Valid	0	
F738	Over-current 1 Protection Coefficient	0.50~3.00	2.50	
F739	Over-current 1 Protection Record			△
F740	Reserved			
F741	Analog Disconnected Protection	0: Invalid 1: Stop and AErr displays. 2: Stop and AErr is not displayed. 3: Inverter runs at the min frequency. 4: Reserved.	0	√
F742	Threshold of Analog Disconnected Protection (%)	1~100	50	○
F745	Threshold of Pre-alarm Overheat (%)	0~100	80	○*
F747	Carrier Frequency Auto-adjusting	0: Invalid 1: Valid	1	√
F754	Zero-current Threshold (%)	0~200	5	×

Function Code	Function Definition	Setting Range	Mfr's Value	Change
F755	Duration time of zero-current	0~60	0.5	√

**Motor parameters: F800-F830**

Function Code	Function Definition	Setting Range	Mfr's Value	Change
F800	Motor's Parameters Selection	Setting range: 0: Invalid; 1: Rotating tuning.; 2: Stationary tuning	0	×
F801	Rated Power	0.2~1000kW		○×
F802	Rated Voltage	1~440V		○×
F803	Rated Current	0.1~6500A		○×
F804	Number of Motor Poles	2~100	4	○△
F805	Rated Rotary Speed	1~30000		○×
F806	Stator Resistance	0.001~65.00Ω		○×
F807	Rotor Resistance	0.001~65.00Ω		○×
F808	Leakage Inductance	0.01~650.0mH		○×
F809	Mutual Inductance	0.1~6500mH		○×
F810	Motor Rated Power	1.00~300.0Hz	50.00	○×
F812	Pre-exciting Time	0.000~3.000S	0.30	√
F813	Rotary Speed Loop KP1	0.01~20.00	Subject to inverter model	○√
F814	Rotary Speed Loop KI1	0.01~2.00	Subject to inverter model	○√
F815	Rotary Speed Loop KP2	0.01~20.00	Subject to inverter model	○√
F816	Rotary Speed Loop KI2	0.01~2.00	Subject to inverter model	○√
F817	PID Switching Frequency 1	0~F111	5.00	√
F818	PID Switching Frequency 2	F817~F111	50.00	√
F819~ F860	Reserved		Subject to inverter model	√
F870	Motor back electromotive force	0.1~999.9 (valid value between lines)	Subject to inverter model	√
F871	D-axis inductance	0.01~655.35	Subject to inverter model	√

# 15-15 Parameter Reference

Function Code	Function Definition	Setting Range	Mfr's Value	Change
F872	Q-axis inductance	0.01~655.35	Subject to inverter model	√
F876	Stator resistance (phase resistance)	0.001~65.535 (phase resistor)	20.0	√
F877	Injection current without load (%)	0.0~100.0 %	0.0	√
F878	Cut-off point of injection current compensation without load(%)	0.0~50.0 %	10.0	√
F880	PCE detection time(S)	0.0~50.0 %	0.2	√
		0.0~10.0 S		

## Communication parameter: F900-F930

Function Code	Function Definition	Setting Range	Mfr's Value	Change
F900	Communication Address	1~255: single inverter address 0: broadcast address	1	√
F901	Communication Mode	1: ASCII 2: RTU	1	○√
F902	Reserved			
F903	Parity Check	0: Invalid 1: Odd 2: Even	0	√
F904	Baud Rate	0: 1200 1: 2400 2: 4800 3: 9600 4: 19200 5: 38400 6: 57600	3	√
F905	Communication Timeout	0.0~3000.0	0.0	√
F906-F930	Reserved			

## PID parameters: FA00-FA80

Function Code	Function Definition	Setting Range	Mfr's Value	Change
FA01	PID reference signal source	0: FA04 1: AI1 2: AI2	0	×
FA02	PID feedback signal source	1: AI1 2: AI2	0	√
FA03	Max limit of PID adjusting (%)	FA04~100.0	10.00	√
FA04	Digital setting value of PID adjusting (%)	FA05~FA03	50.0	√
FA05	Min limit of PID adjusting (%)	0.0~FA04	0.0	√

Function Code	Function Definition	Setting Range	Mfr's Value	Change
FA06	PID polarity	0: Positive feedback 1: Negative feedback	1	×
FA07	Sleep function selection	0: Valid 1: Invalid	0	×
FA09	Min frequency of PID adjusting (Hz)	Max(F112, 0.1)~F111	5.00	√
FA10	Sleep delay time (S)	0~500.0	15.0	√
FA11	Wake delay time (S)	0.0~3000	3.0	√
FA18	Whether PID adjusting target is changed	0: Invalid 1: Valid	1	×
FA19	Proportion Gain P	0.00~10.00	0.3	√
FA20	Integration time I (S)	0.0~100.0S	0.3	√
FA21	Differential time D (S)	0.00~10.00	0.0	√
FA22	PID sampling period (S)	0.1~10.0s	0.1	√
FA29	PID dead time (%)	0.0~10.0	2.0	√
FA58	Fire pressure given value (%)	0.0~100.0	80.0	√
FA59	Emergency fire mode	0: Invalid 1: Emergency fire mode 1 2: Emergency fire mode 2	0	√
FA60	Running frequency of emergency fire	F112~F111	50.0	√
FA61	Reserved			
FA62	when emergency fire control terminal is invalid	0: inverter cannot be stopped manually 1: inverter can be stopped manually	0	×
FA63-FA80	Reserved			

**Torque control parameters: FC00-FC40**

Function Code	Function Definition	Setting Range	Mfr's Value	Change
FC00	Speed/torque control selection	0: Speed control 1: Torque control 2: Terminal switchover	0	√
FC01	Delay time of torque/speed control switchover (S)	0.0~1.0	0.1	×
FC02	Torque accel/decel time (S)	0.1~100.0	1	√
FC03-FC05	Reserved			
FC06	Torque reference source	0: Digital given (FC09) 1: Analog input AI1 2: Analog input AI2	0	×
FC07	Torque reference coefficient	0~3.000	3.000	×
FC08	Reserved			
FC09	Torque reference command value (%)	0~300.0	100.0	√



# 15-17 Parameter Reference

Function Code	Function Definition	Setting Range	Mfr's Value	Change
FC10-FC13	Reserved			
FC14	Offset torque reference source	0: Digital given (FC17) 1: Analog input AI1 2: Analog input AI2	0	×
FC15	Offset torque coefficient	0~0.500	0.500	×
FC16	Offset torque cut-off frequency (%)	0~100.0	10.00	×
FC17	Offset torque command value (%)	0~50.0	10.00	√
FC18-FC21	Reserved			
FC22	Forward speed limit source	0: Digital given (FC23) 1: Analog input AI1 2: Analog input AI	0	×
FC23	Forward speed limit (%)	0~100.0	10.00	√
FC24	Reverse speed limit source	0: Digital given (FC25) 1: Analog input AI1 2: Analog input AI	0	×
FC25	Reverse speed limit (%)	0~100.0	10.00	√
FC26-FC27	Reserved			
FC28	Driving torque limit source	0: Digital given (FC30) 1: Analog input AI1 2: Analog input AI2	0	×
FC29	Driving torque limit coefficient	0~3.000	3.000	×
FC30	Driving torque limit (%)	0~300.0	200.0	√
FC31	Reserved			
FC32	Reserved			
FC33	Re-generating torque limit source	0: Digital given (FC35) 1: Analog input AI1 2: Analog input AI2	0	×
FC34	Re-generating torque limit coefficient	0~3.000	3.000	
FC35	Re-generating torque limit (%)	0~300.0	200.00	√
FC36-FC40	Reserved			

Note:

× indicating that function code can only be modified in stop state.

√ indicating that function code can be modified both in stop and run state.

△ indicating that function code can only be checked in stop or run state but cannot be modified.

○ indicating that function code cannot be initialized as inverter restores manufacturer's value but can only be modified manually.